



# ATD-7465

## VEHICLE POSITIONING JACK

### OPERATING INSTRUCTIONS

#### WARNING!

- Read **ALL** the instructions and warnings before attempting to operate this jack.
- **DO NOT** operate jack on inclined surfaces. Jack must be used on level surfaces only. Unanticipated motion will occur as soon as jack lifts tire from surface.
- **DO NOT** overload jack beyond the load rating (1500lbs per unit)
- **DO NOT** start the vehicle's engine, or drive with jack in use. Jacks are designed for hand maneuvering of vehicles only.
- **DO NOT** use jack to lift tires wider than 12 inches.
- **DO NOT** attempt to push jack over obstacles. They are designed to be used on level surfaces only.
- After lifting, be sure always lock the pin in place before operating. Pull the pin out after finishing work and then release the valve.

#### TO OPERATE:

Place jack on floor and press down on pedal to release pedal lock. Pull out the lock pin from frame.

Before operating, open release valve by turning hand wheel counter-clockwise. Expand jack with hand wheel, enough to place around tire and position so both rollers now contact the tire tread. To obtain the best control of jack while expanding around tire, place your left hand on top of the left side axle and your right hand at the center of the pedal. Close release valve by turning hand wheel clockwise to a snug-tight position, jack may now be used.

**IMPORTANT:** Install jack so that the unit is parallel to the sidewall of the tire to be lifted. Leave approximately 3/4" of clearance between tire and jack. If unit is misaligned, it is possible that the tire will be forced to hit the axle of the jack and not the rollers. This may damage the jack and will void the warranty.

To lift tire, flip directional lever up and place foot on pedal depressing with smooth, even strokes. Cycle pedal until tire is lifted about an inch from the surface. The lower the tire is to the surface the more stable the jack will be. After lifting, be sure to always lock the pin in place before operating. Repeat this process on the other tires and maneuver the vehicle as required.

To release jack, pull the pin out from frame and open valve by turning hand-wheel counter clockwise slowly. Jack may be removed only when rollers are disengaged from the tire.



# ATD-7465

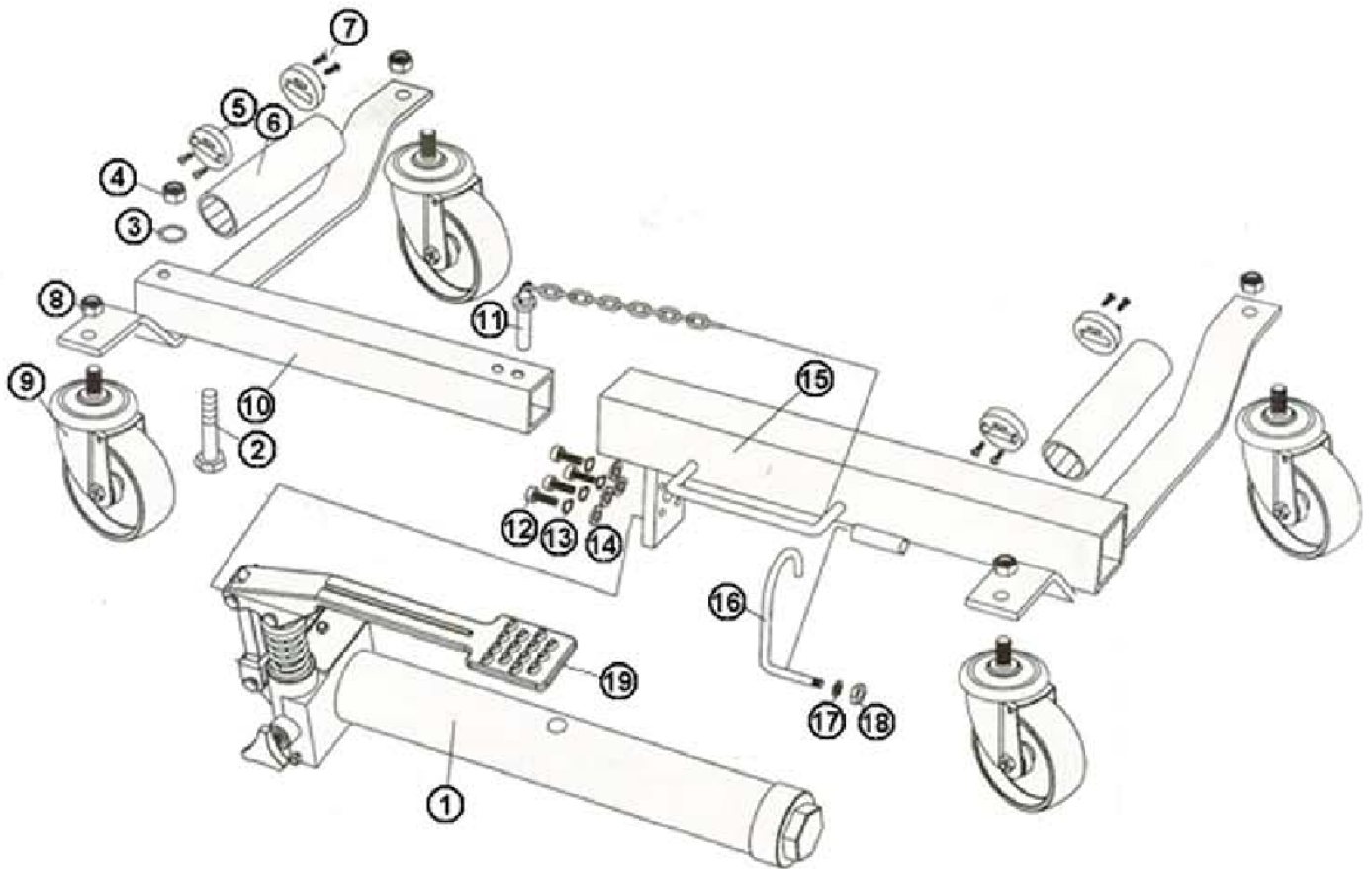

ITEM#	ORDERING PART#	PART DESCRIPTION
1	PRT7465-01	RAM ASSEMBLY*
2	PRT7465-20	BOLT M16X115
3	PRT7465-20	FLAT WASHER $\Phi$ 16
4	PRT7465-20	NUT M16
5	PRT7465-20	ROLLER RACEWAY (4 pcs)
6	PRT7465-06	ROLLER (2 pcs)
7	PRT7465-20	RACEWAY LOCK SCREW (8 pcs)
8	PRT7465-20	LOCK NUT M12 (4 pcs)
9	PRT7465-09	4" SWIVEL CASTER (4 pcs)
10	PRT7465-10	LEFT FRAME

ITEM#	ORDERING PART#	PART DESCRIPTION
11	PRT7465-11	LOCK PIN WITH CHAIN
12	PRT7465-20	SCREW M6X20 (4 pcs)
13	PRT7465-20	LOCK WASHER $\Phi$ 6 (4 pcs)
14	PRT7465-20	FLAT WASHER $\Phi$ 6 (4 pcs)
15	PRT7465-15	RIGHT FRAME
16	PRT7465-20	HOOK
17	PRT7465-20	WASHER FOR HOOK
18	PRT7465-20	NUT FOR HOOK
19	PRT7465-19	FOOT PEDAL
20	PRT7465-20	HARDWARE KIT*

\*PRT7465-20 Hardware kit includes items: 2, 3, 4, 5, 7, 8, 12, 13, 14, 16, 17, 18  
 And is included with PRT7465-01 Ram Assembly