

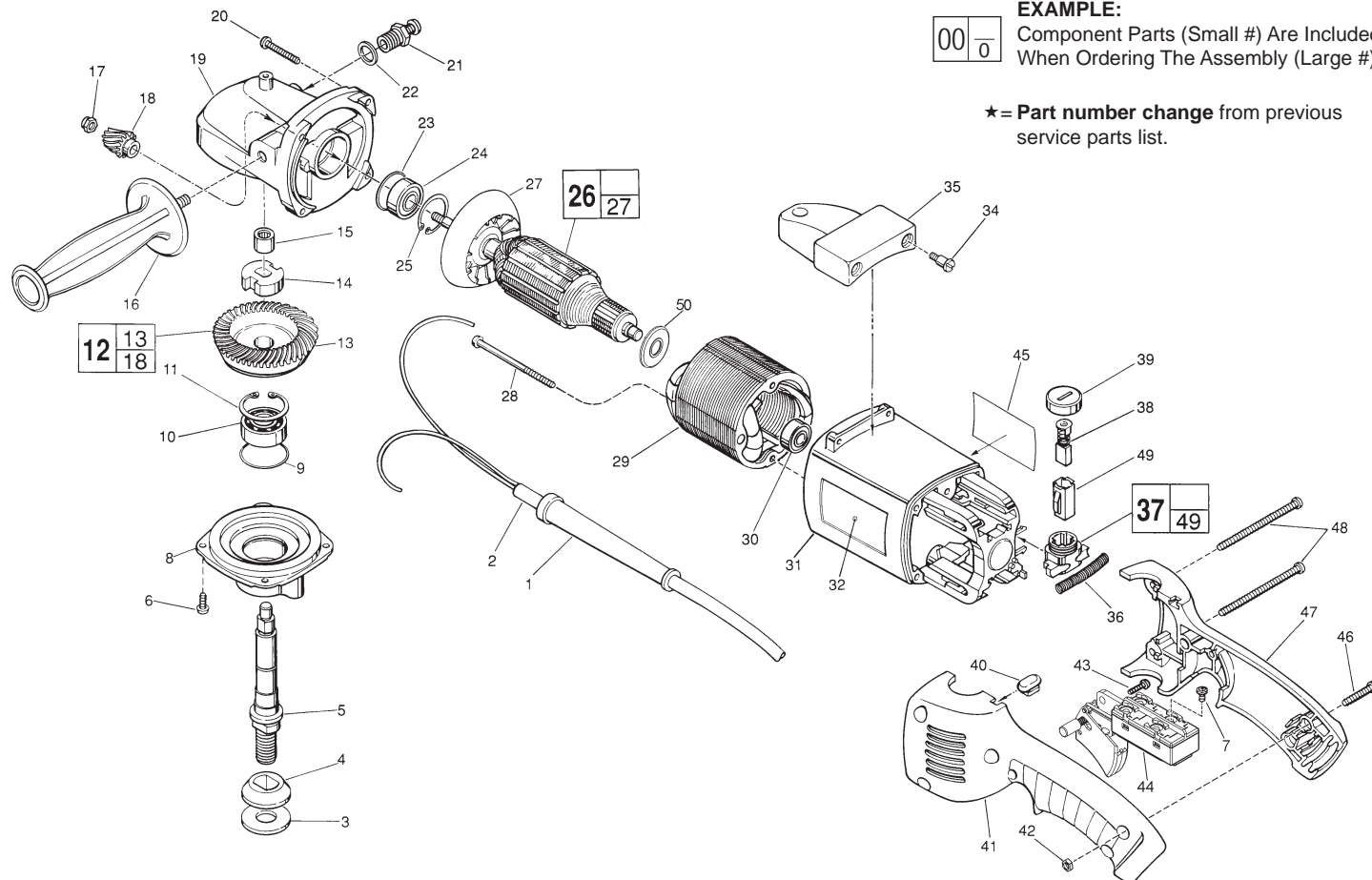

SERVICE PARTS LIST

BULLETIN NO.
54-38-0288

| SPECIFY CATALOG NO. AND SERIAL NO. WHEN ORDERING PARTS | | REVISED BULLETIN | DATE |
|--|----------------------|--|----------|
| 9" SANDER | | 54-38-0287 | May 2009 |
| CATALOG NO. | 6072 | WIRING INSTRUCTION 58-01-0314 | |
| | SERIAL NUMBER | 703E | |



EXAMPLE:
00 0

Component Parts (Small #) Are Included When Ordering The Assembly (Large #).

★ = Part number change from previous service parts list.

| FIG. | PART NO. | DESCRIPTION OF PART | NO REQ. |
|------|----------|--|---------|
| | 1 | 44-76-0050 Cord Protector | (1) |
| | 2 | 22-64-0785 Cord Set | (1) |
| | 3 | 45-88-8465 Spindle Washer | (1) |
| | 4 | 49-05-0060 Spindle Washer - Flange | (1) |
| | 5 | 38-50-5645 Spindle Shaft | (1) |
| | 6 | 06-82-8864 10-24 x 1/2" Pan Hd. Sems T-25 Screw | (4) |
| ★ | 7 | 05-78-0305 Switch Screw T-15 | (4) |
| | 8 | 28-14-1900 Lower Gear Case | (1) |
| | 9 | 34-40-1550 1-9/16" O-Ring | (1) |
| | 10 | 02-04-1745 Ball Bearing | (1) |
| | 11 | 34-80-2960 Retaining Ring - Internal | (1) |
| | 12 | 14-46-4320 Bevel Gear Kit | (1) |
| | 13 | 32-05-1291 Spiral Bevel Gear | (1) |
| | 14 | 42-74-0080 Spindle Locking Cog | (1) |
| | 15 | 02-50-2423 Needle Bearing | (1) |
| | 16 | 43-62-1265 Side Handle | (1) |
| | 17 | 06-57-0500 Lock Nut | (1) |
| | 18 | 32-60-2201 Spiral Bevel Pinion | (1) |
| | 19 | 28-14-2090 Upper Gear Case | (1) |
| | 20 | 06-82-7224 10-14 x 1" Pan Hd. Plastite T-25 Screw | (4) |
| | 21 | 44-20-0235 Spindle Lock Assembly | (1) |
| | 22 | 45-88-5320 Flat Washer | (1) |
| | 23 | 34-40-1375 1-1/4" O-Ring | (1) |
| | 24 | 02-04-1860 Ball Bearing | (1) |
| | 25 | 34-80-2600 Retaining Ring - Internal | (1) |
| | 26 | 16-50-1185 120 V. Armature | (1) |
| | 27 | 22-84-0710 Fan | (1) |
| | 28 | 06-82-7375 8-16 x 2-1/2" Pan Hd. Plastite T-20 Screw | (2) |
| | 29 | 18-50-0170 120 V. Field | (1) |
| | 30 | 02-04-0845 Ball Bearing | (1) |

| FIG. | PART NO. | DESCRIPTION OF PART | NO REQ. |
|------|----------|--|---------|
| | 31 | 31-50-0548 Motor Housing | (1) |
| | 32 | 12-20-6105 Service Nameplate Kit | (1) |
| | 34 | 45-04-0720 Shoulder Screw | (3) |
| | 35 | 31-70-0140 Tool Rest | (1) |
| | 36 | 40-50-7770 Brush Holder Spring | (2) |
| | 37 | 22-22-1325 Brush Holder Assembly | (2) |
| | 38 | 22-18-0680 Brush Assembly | (2) |
| | 39 | 23-44-0210 Brush Retaining Screw | (2) |
| | 40 | 42-38-0190 Bumper | (1) |
| ★ | 41 | 31-44-1717 Left Handle Half | (1) |
| | 42 | 06-55-1050 10-24 Hex Nut | (5) |
| | 43 | 06-82-7409 8-16 x 1/2" Slot. Pan Hd. T-20 Screw | (1) |
| ★ | 44 | 23-66-1801 Switch | (1) |
| ★ | 45 | 10-98-1806 Warning Label | (1) |
| | 46 | 06-82-2568 10-24 x 7/8" Slot. Pan Hd. T-25 Screw | (3) |
| ★ | 47 | 31-44-1718 Right Handle Half | (1) |
| | 48 | 06-82-2598 10-24 x 2-3/4" Slot. Pan Hd. T-25 Screw | (2) |
| | 49 | 22-20-0660 Brush Tube | (2) |
| | 50 | 23-16-1700 Commutator Insulator | (1) |

FIG. LUBRICATION:

19 **Important!** Completely clean out old grease from the upper gearcase and replace with 1.5 Oz. Type "Y" Grease, No. 49-08-5270.

FIG. NOTE:

17 Torque To 125-135 In./Lbs.

MILWAUKEE ELECTRIC TOOL CORPORATION
13135 W. LISBON RD., BROOKFIELD, WI 53005