



SERVICE PARTS LIST

BULLETIN NO.
54-38-2681

SPECIFY CATALOG NO. AND SERIAL NO. WHEN ORDERING PARTS		REVISED BULLETIN 54-38-2680	DATE Feb. 2014
CORDLESS 18 VOLT 4-1/2" CUT-OFF/GRINDER			
CATALOG NO. 2680-20	STARTING SERIAL NO. B96B	WIRING INSTRUCTION SEE PAGE 2	

EXAMPLE:
00 0 Component Parts (Small #) Are Included
When Ordering The Assembly (Large #).

★ = Part number change from previous service parts list.

FIG. LUBRICATION:
(Use Type 'Y' grease, No. 49-08-5270)

- 10 Apply a thin coat of grease to the Spindle Hub O-Ring.
- 13,38 Apply grease to all teeth of the Pinion and Gear.
- 27 Place 1/8 oz. grease in Gearcase cavity.
- 32,33 Apply a thin coat of grease between Spindle Lock Shaft and O-Ring.

Functionally check the Spindle Lock mechanism. Spindle Lock must return briskly when released from engagement in Gear (13).

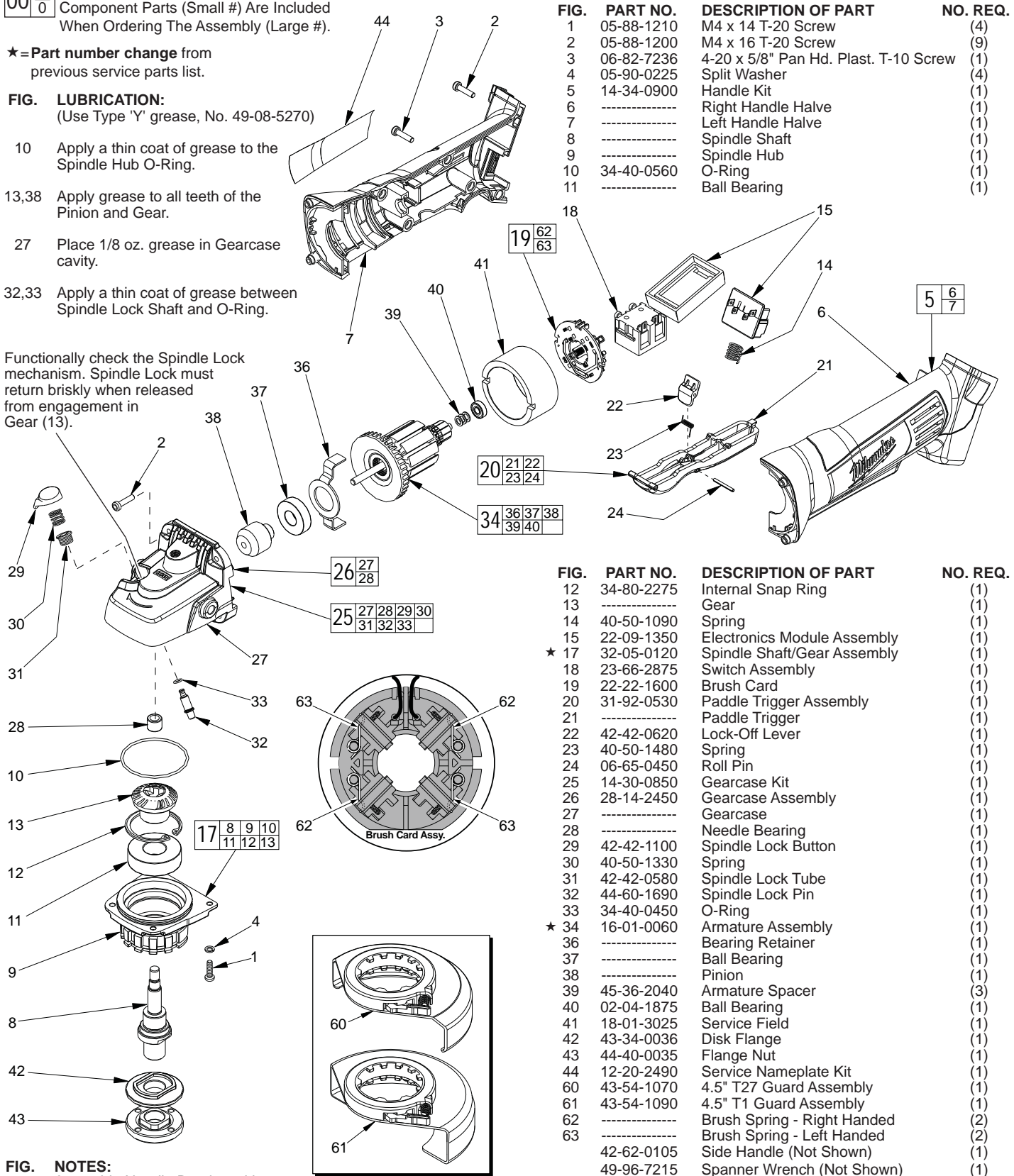

FIG.	PART NO.	DESCRIPTION OF PART	NO. REQ.
1	05-88-1210	M4 x 14 T-20 Screw	(4)
2	05-88-1200	M4 x 16 T-20 Screw	(9)
3	06-82-7236	4-20 x 5/8" Pan Hd. Plast. T-10 Screw	(1)
4	05-90-0225	Split Washer	(4)
5	14-34-0900	Handle Kit	(1)
6	-----	Right Handle Half	(1)
7	-----	Left Handle Half	(1)
8	-----	Spindle Shaft	(1)
9	-----	Spindle Hub	(1)
10	34-40-0560	O-Ring	(1)
11	-----	Ball Bearing	(1)

FIG.	PART NO.	DESCRIPTION OF PART	NO. REQ.
12	34-80-2275	Internal Snap Ring	(1)
13	-----	Gear	(1)
14	40-50-1090	Spring	(1)
15	22-09-1350	Electronics Module Assembly	(1)
★ 17	32-05-0120	Spindle Shaft/Gear Assembly	(1)
18	23-66-2875	Switch Assembly	(1)
19	22-22-1600	Brush Card	(1)
20	31-92-0530	Paddle Trigger Assembly	(1)
21	-----	Paddle Trigger	(1)
22	42-42-0620	Lock-Off Lever	(1)
23	40-50-1480	Spring	(1)
24	06-65-0450	Roll Pin	(1)
25	14-30-0850	Gearcase Kit	(1)
26	28-14-2450	Gearcase Assembly	(1)
27	-----	Gearcase	(1)
28	-----	Needle Bearing	(1)
29	42-42-1100	Spindle Lock Button	(1)
30	40-50-1330	Spring	(1)
31	42-42-0580	Spindle Lock Tube	(1)
32	44-60-1690	Spindle Lock Pin	(1)
33	34-40-0450	O-Ring	(1)
★ 34	16-01-0060	Armature Assembly	(1)
36	-----	Bearing Retainer	(1)
37	-----	Ball Bearing	(1)
38	-----	Pinion	(1)
39	45-36-2040	Armature Spacer	(3)
40	02-04-1875	Ball Bearing	(1)
41	18-01-3025	Service Field	(1)
42	43-34-0036	Disk Flange	(1)
43	44-40-0035	Flange Nut	(1)
44	12-20-2490	Service Nameplate Kit	(1)
60	43-54-1070	4.5" T27 Guard Assembly	(1)
61	43-54-1090	4.5" T1 Guard Assembly	(1)
62	-----	Brush Spring - Right Handed	(2)
63	-----	Brush Spring - Left Handed	(2)
42-62-0105	-----	Side Handle (Not Shown)	(1)
49-96-7215	-----	Spanner Wrench (Not Shown)	(1)

- FIG. NOTES:**
- 28 Assemble Needle Bearing with vendor I.D. facing the Gear.
 - 37 Assemble Ball Bearing with seal towards Pinion and shield towards Armature.

AS AN AID TO REASSEMBLY, TAKE NOTICE OF WIRE ROUTING AND POSITION IN WIRE GUIDES AND TRAPS WHILE DISMANTLING TOOL.

PC BOARD
(Component of the Electronics Module Assembly)

⑧ BLACK
(From Terminal Block to PCB)

SWITCH ASSEMBLY

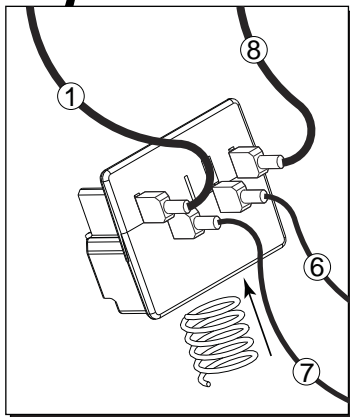
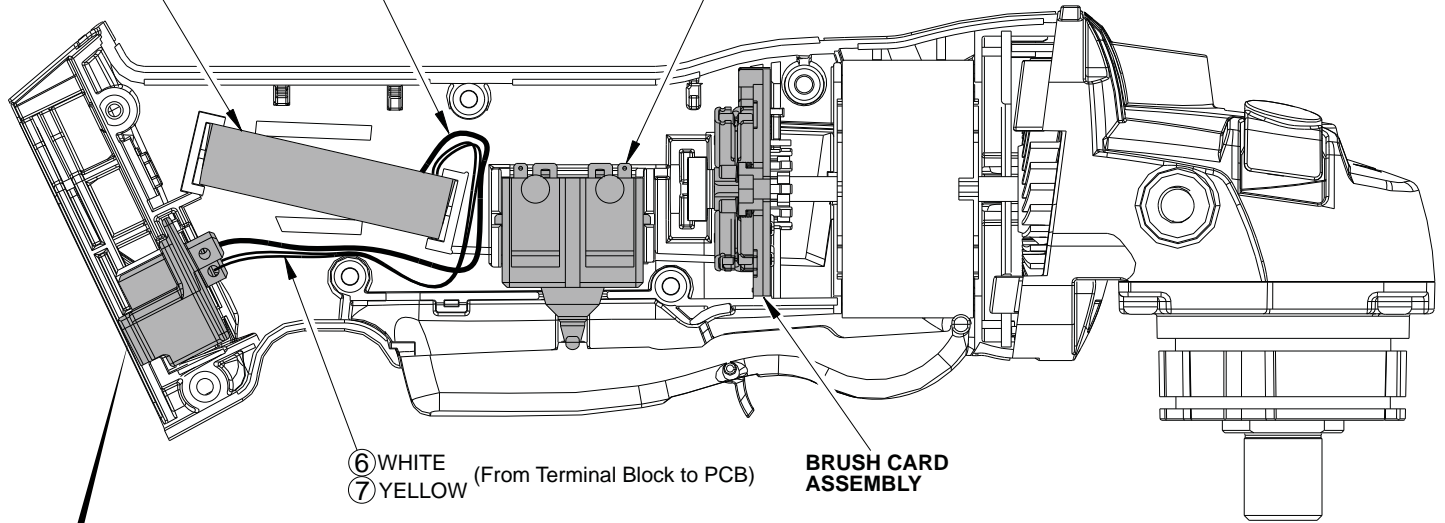

BLACK ②
(From Switch to PCB)

④ BLACK
(From Brush Card to Switch)

RED ③ (From Switch to PCB)

⑤ RED
(From Brush Card to Switch)

CONNECTOR BLOCK
(Component of the Electronics Module Assembly)

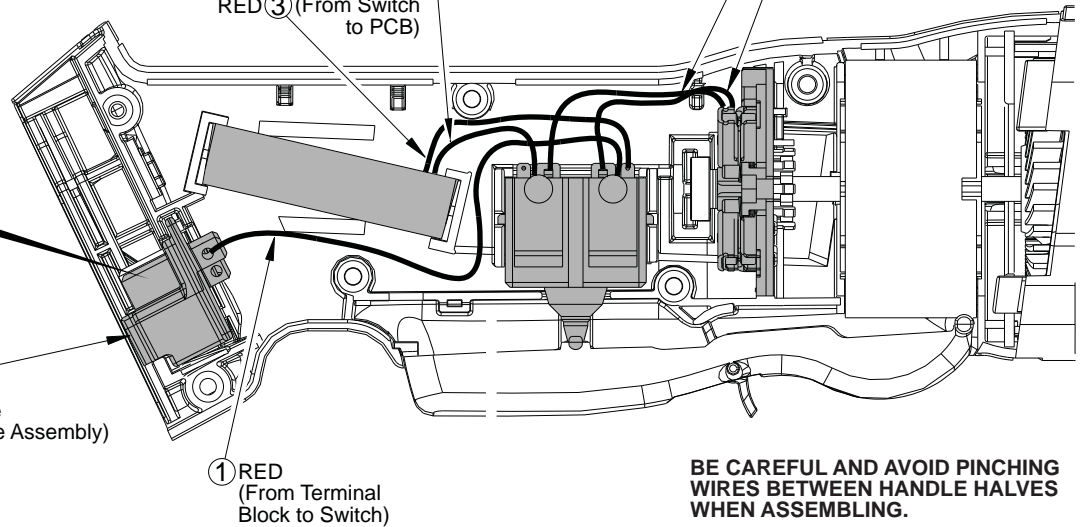

BE CAREFUL AND AVOID PINCHING WIRES BETWEEN HANDLE HALVES WHEN ASSEMBLING.

WIRING SPECIFICATIONS

Wire No.	Wire Color	Origin or Gauge	Length	Terminals, Connectors and 1 or 2 End Wire Preparation
1	Red	14	-----	Component of the Electronics Module Assembly.
2	Black	14	-----	Component of the Electronics Module Assembly.
3	Red	18	-----	Component of the Electronics Module Assembly.
4	Black	15	-----	Component of the Brush Card Assembly.
5	Red	15	-----	Component of the Brush Card Assembly.
6	White	24	-----	Component of the Electronics Module Assembly.
7	Yellow	24	-----	Component of the Electronics Module Assembly.
8	Black	14	-----	Component of the Electronics Module Assembly.

