

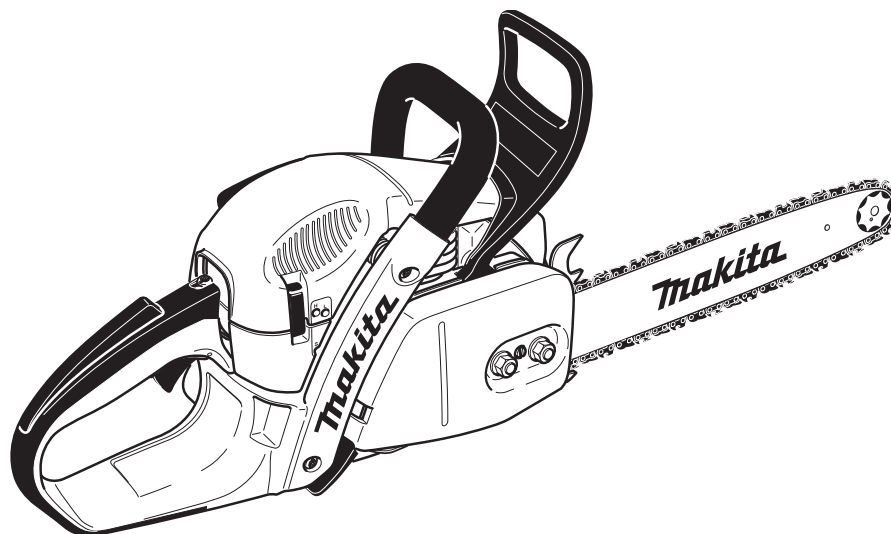

Spare Parts List
Ersatzteilliste
Liste de pièces détachées
Lista de piezas de repuesto

2012-11



- DCS460
- DCS461
- DCS500
- DCS501
- DCS4600S
- DCS4600SH
- DCS5000
- DCS5000H
- DCS5001
- DCS5001H
- DCS5121
- DCS460 (USA)
- DCS510 (USA)
- DCS5121 (USA)
- DE5045

995700548 (D, GB, F, E)

DCS460, DCS461, DCS500, DCS501,
DCS4600S, DCS4600SH, DCS5000,
DCS5000H, DCS5001, DCS5001H, DCS5121,
DCS460, DCS510, DCS5121, DE5045

1

Kraftstofftank, Bügelgriff
Fuel tank, tubular grip
Réserv. carburant, poignée tubulaire
Depósito de combustible, mango tubular

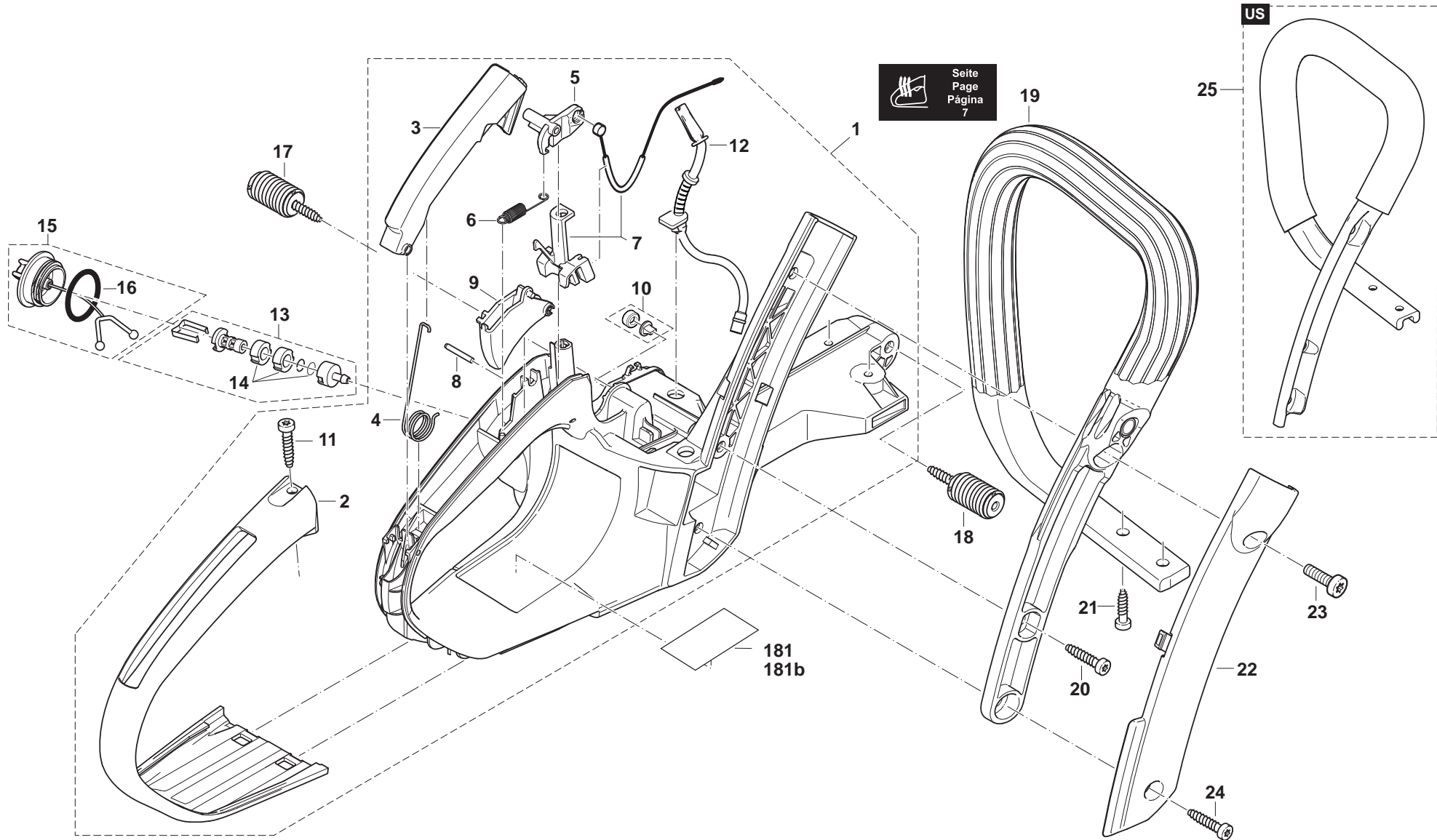

DCS460, DCS461, DCS500, DCS501,
DCS4600S, DCS4600SH, DCS5000,
DCS5000H, DCS5001, DCS5001H, DCS5121,
DCS460, DCS510, DCS5121, DE5045

1

Kraftstofftank, Bügelgriff
Fuel tank, tubular grip
Réserv. carburant, poignée tubulaire
Depósito de combustible, mango tubular



Seite / Page	Pos.	DCS460	DCS461	DCS500	DCS501	DCS4600S	DCS4600SH	DCS5000	DCS5000H	DCS5001	DCS5001H	DCS5121	DCS460 (USA)	DCS510 (USA)	DCS5121 (USA)	DE5045	Teil-Nr. Part No. No. de pièce No. de pieza	Hinweise Notes Renseign. Nota	Bezeichnung	Spezifikation Specification	Description	Désignation	Denominación
1	1	1	1	1	1	1	1	1	1	1	1	1				1	181 114 605		KRAFTSTOFFTANK BLAU KPL.		FUEL TANK CPL. BLUE	RÉSERVOIR CPL. BLEU	DEPÓSITO CPL. AZUL
1	1												1	1	1		181 114 720		KRAFTSTOFFTANK BLAU KPL.	USA (EPA), INCL.181b	TANK CPL. BLUE	RÉSERVOIR CPL. BLEU	DEPÓSITO CPL. AZUL
1	2	1	1	1	1	1	1	1	1	1	1	1	1	1	1	1	181 117 050		GRIFFOBERSCHALE SCHWARZ		GRIP OUTER SHELL, BLACK	COQUILLE DE POIGNÉE SUPÉR.	CUBIERTA SUPER. EMPUÑADURA
1	3	1	1	1	1	1	1	1	1	1	1	1	1	1	1	1	181 117 132		SICHERHEITSSPERRTAS TE		CATCH LEVER	LEVIER DE VERROUILLAGE	PALANCA TRINCADA
1	4	1	1	1	1	1	1	1	1	1	1	1	1	1	1	1	181 117 031		DREHFEDER FÜR SPERRTASTE		SPRING	RESSORT	RESORTE
1	5	1	1	1	1	1	1	1	1	1	1	1	1	1	1	1	181 117 081		UMLENKHEBEL		ROCKER	LEVIER DE RENVOI	PALANCA DE CAMBIO
1	6	1	1	1	1	1	1	1	1	1	1	1	1	1	1	1	181 117 110		ZUGFEDER FÜR UMLENKHEBEL		SPRING	RESSORT	RESORTE
1	7	1	1	1	1	1	1	1	1	1	1	1	1	1	1	1	010 117 050	TI 2005/13	UMBAUSATZ	INCL. 30	MODIFICATION SET	JEU DE MODIFICATION	JUEGO DE MODIFICACIÓN
1	8	1	1	1	1	1	1	1	1	1	1	1	1	1	1	1	935 930 240		ZYLINDERSTIFT	3x24	CYLINDRICAL PIN	GOUPILLE CYL.	PRISIONERO
1	9	1	1	1	1	1	1	1	1	1	1	1	1	1	1	1	181 117 121	2006-09 =>	GASHEBEL		THROTTLE LEVER	LEVIER D' ACCÉLÉRRATION	ACELERADOR
1	9	1	1	1	1	1	1	1	1	1	1	1	1	1	1	1	181 117 120	=> 2006-08	GASHEBEL		THROTTLE LEVER	LEVIER D' ACCÉLÉRRATION	ACELERADOR
1	10	1	1	1	1	1	1	1	1	1	1	1	1	1	1	1	957 114 061		BELÜFTUNGSVENTIL KPL.		AIR VALVE CPL.	SOUPAPE D'AERATION CPL.	VÁLVULA VENTILACION CPL.
1	11	1	1	1	1	1	1	1	1	1	1	1	1	1	1	1	913 455 204		SCHRAUBE	5,5x20	SCREW	VIS	TORNILLO
1	12	1	1	1	1	1	1	1	1	1	1	1	1	1	1	1	181 114 065		KRAFTSTOFFLEITUNG	EPA code	FUEL LINE	CONDUITE CARB.	TUBO COMB.
1	13	1	1	1	1	1	1	1	1	1	1	1	1	1	1	1	010 114 010		SAUGKOPF KPL.		SUCTION HEAD	TETE D'ASPIRATION	CABEZA DE ASPIRACION
1	14	1	1	1	1	1	1	1	1	1	1	1	1	1	1	1	010 114 020		REPARATUR-SATZ, FILTER (JE 5 STCK.)		REP. KIT, FILTER (5 OF EACH)	JEU DE RÉPARAT., FILTRE	JUEGO DE REPARAR, FILTRO
1	15	1	1	1	1	1	1	1	1	1	1	1	1	1	1	1	181 114 202		TANKDECKEL KPL.		TANK CAP CPL.	BOUCHON RESERVOIR CPL.	TORNILLO DE CIERRE CPL.
1	16	1	1	1	1	1	1	1	1	1	1	1	1	1	1	1	963 229 036		O-RING	29,3X3,6	PACKING RING	BAGUE-JOINT	ANILLO DE GUARNICION
1	17	1	1	1	1	1	1	1	1	1	1	1	1	1	1	1	181 114 301		DÄMPFUNGSFEDER KPL.		DAMPING SPRING, CPL.	RESSORT D'AMORTISS. CPL.	MUELLE DE AMORTIGUACIÓN CPL.
1	18	1	1	1	1	1	1	1	1	1	1	1	1	1	1	1	181 114 301		DÄMPFUNGSFEDER KPL.		DAMPING SPRING, CPL.	RESSORT D'AMORTISS. CPL.	MUELLE DE AMORTIGUACIÓN CPL.
1	19	1	1	1	1	1	1	1	1	1	1	1	1	1	1	1	181 310 200		BÜGELGRIFF	Kst.	TUBULAR HANDLE	POIGNÉE TUBULAIRE	MANGO TUBULAR
1	20	1	1	1	1	1	1	1	1	1	1	1	1	1	1	1	913 455 204		SCHRAUBE	5,5x20	SCREW	VIS	TORNILLO
1	21	2	2	2	2	2	2	2	2	2	2	2	2	2	2	2	913 455 164		INNENSTERN SCHRAUBE	5,5X16	SCREW	VIS	TORNILLO
1	22	1	1	1	1	1	1	1	1	1	1	1	1	1	1	1	181 114 652		ABDECKUNG SEITENSTREBE BLAU	MAKITA	COVER	COUVERCLE	CUBIERTA

DCS460, DCS461, DCS500, DCS501,
DCS4600S, DCS4600SH, DCS5000,
DCS5000H, DCS5001, DCS5001H, DCS5121,
DCS460, DCS510, DCS5121, DE5045

1

Kraftstofftank, Bügelgriff
Fuel tank, tubular grip
Réserv. carburant, poignée tubulaire
Depósito de combustible, mango tubular

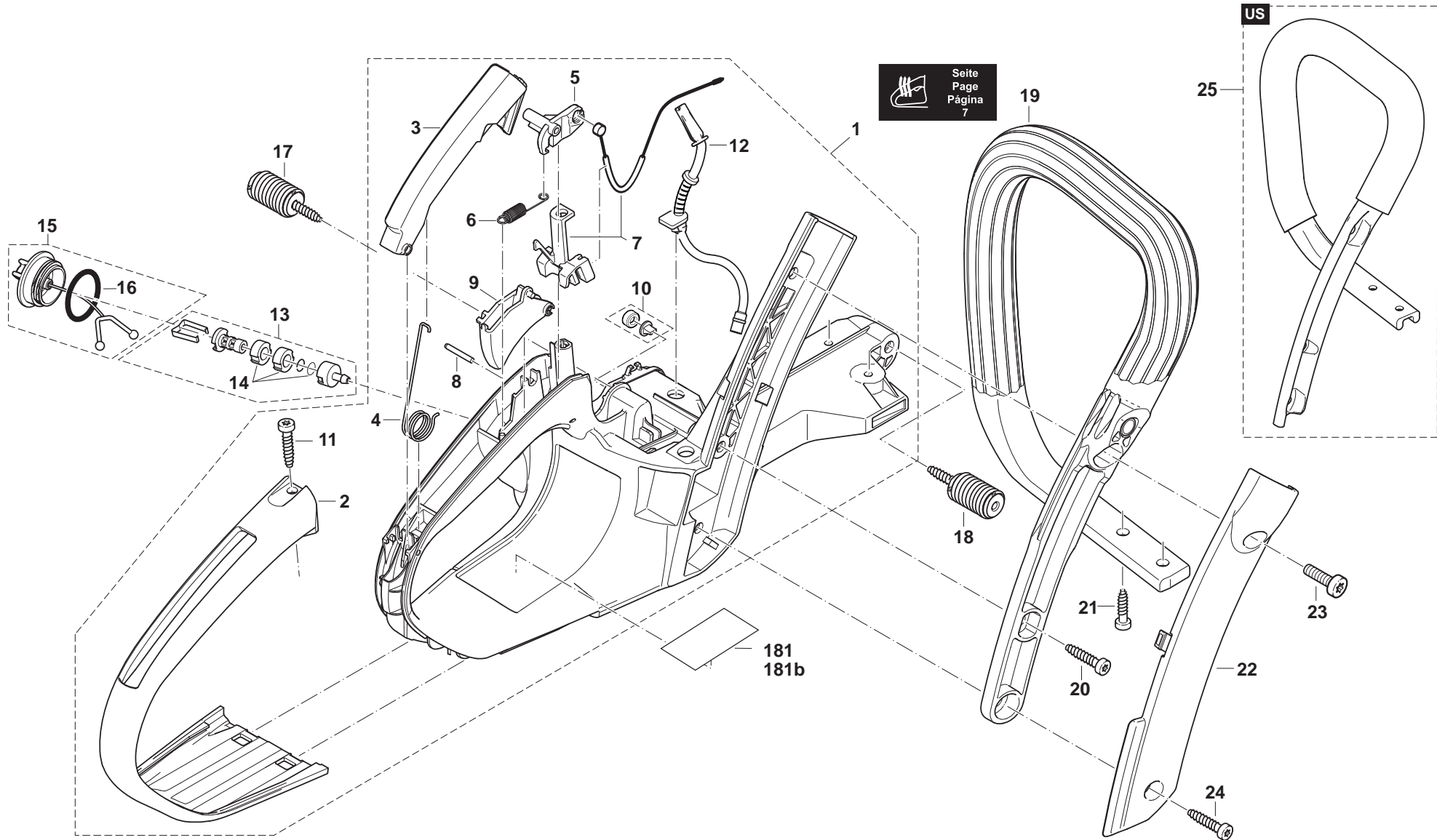

DCS460, DCS461, DCS500, DCS501,
DCS4600S, DCS4600SH, DCS5000,
DCS5000H, DCS5001, DCS5001H, DCS5121,
DCS460 , DCS510 , DCS5121 , DE5045

1

Kraftstofftank, Bügelgriff
Fuel tank, tubular grip
Réserv. carburant, poignée tubulaire
Depósito de combustible, mango tubular



Seite / Page	Pos.	DCS460	DCS461	DCS500	DCS501	DCS4600S	DCS4600SH	DCS5000	DCS5000H	DCS5001	DCS5001H	DCS5121	DCS460 (USA)	DCS510 (USA)	DCS5121 (USA)	DE5045	Teil-Nr. Part No. No. de pièce No. de pieza	Hinweise Notes Renseign. Nota	Bezeichnung	Spezifikation Specification	Description	Désignation	Denominación
1	23	1	1	1	1	1	1	1	1	1	1	1	1	1	1	1	908 006 205		INNENSTERN-SCHRAUB E	M6x20	SCREW	VIS	TORNILLO
1	24	1	1	1	1	1	1	1	1	1	1	1	1	1	1	1	913 455 204		SCHRAUBE	5,5x20	SCREW	VIS	TORNILLO
1	25													1	1		181 310 250	USA	BÜGELGRIFF	AI	TUBULAR HANDLE	POIGNÉE TUBULAIRE	MANGO TUBULAR
1	181															1	980 115 253		SICHERHEITSAUFKLEBE R	J	CAUTION LABEL	PLAQUE	CALCOMANIA
1	181b												1	1	1				AUFKLEBER TANK	USA - EVAPORATION MAKITA	LABEL, TANK	PLAQUE, RÉSERVOIR	CALCOMANIA, DEPÓSITO

DCS460, DCS461, DCS500, DCS501,
 DCS4600S, DCS4600SH, DCS5000,
 DCS5000H, DCS5001, DCS5001H, DCS5121,
 DCS460, DCS510, DCS5121, DE5045

2

Abdeckhaube, Luftfilter, Schalldämpfer
 Hood, air filter, muffler
 Capot protecteur, filtre à air, pot d'échappement
 Cubierta protectora, filtro de aire, silencioso

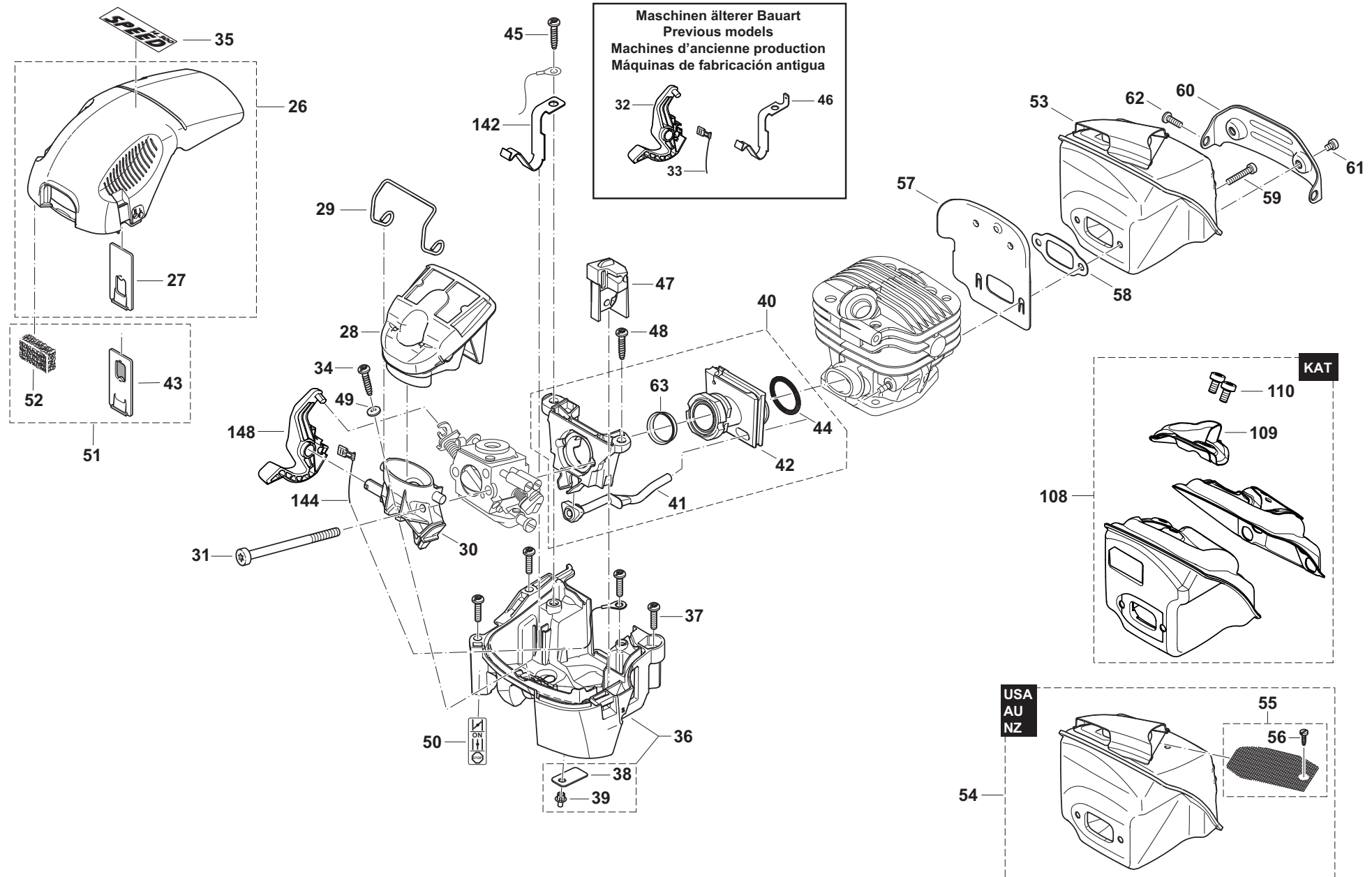

DCS460, DCS461, DCS500, DCS501,
DCS4600S, DCS4600SH, DCS5000,
DCS5000H, DCS5001, DCS5001H, DCS5121,
DCS460 , DCS510 , DCS5121 , DE5045

2

Abdeckhaube, Luftfilter, Schalldämpfer
Hood, air filter, muffler
Capot protecteur, filtre à air, pot d' échappement
Cubierta protectora, filtro de aire, silencioso



Seite / Page	Pos.	DCS460	DCS461	DCS500	DCS501	DCS4600S	DCS4600SH	DCS5000	DCS5000H	DCS5001	DCS5001H	DCS5121	DCS460 (USA)	DCS510 (USA)	DCS5121 (USA)	DE5045	Teil-Nr. Part No. No. de pièce No. de pieza	Hinweise Notes Renseign. Nota	Bezeichnung	Spezifikation Specification	Description	Désignation	Denominación
2	26	1	1	1	1	1	1	1	1	1	1	1					181 118 260	=> 2012-03	ABDECKHAUBE ROT KPL.	KAT (INT / RUS)	HOOD CPL. RED	CAPOT PROT. CPL. ROUGE	TAPA PROT. CPL. ROJO
2	26	1	1	1	1	1	1	1	1	1	1	1					181 118 261	2012-04 =>	ABDECKHAUBE ROT KPL.	KAT TR (INT / RUS)	HOOD CPL. RED	CAPOT PROT. CPL. ROUGE	TAPA PROT. CPL. ROJO
2	26	1	1	1	1	1	1	1	1	1	1	1	1	1	1	1	181 118 620	=> 2012-03	ABDECKHAUBE GRAU KPL.	KAT	HOOD CPL. GREY	CAPOT PROT. CPL. GRIS	TAPA PROT. CPL. GRIS
2	26	1	1	1	1	1	1	1	1	1	1	1	1	1	1	1	181 118 621	2012-04 =>	ABDECKHAUBE GRAU KPL.	KAT TR	HOOD CPL. GREY	CAPOT PROT. CPL. GRIS	TAPA PROT. CPL. GRIS
2	27	1	1	1	1	1	1	1	1	1	1	1	1	1	1	1	181 118 060		EINSATZ	SO/WI	INSERT	PIÈCE D' INSERTION	PIEZA DE CIERRE
2	28	1	1	1	1	1	1	1	1	1	1	1	1	1	1	1	181 173 090		LUFTFILTER KPL.	NYLON	AIR FILTER ASS'Y	FILTRE À AIR CPL.	FILTRO DE AIRE CPL.
2	28	1	1	1	1	1	1	1	1	1	1	1				1	181 173 240		LUFTFILTER KPL., FEIN	NYLON	AIR FILTER CPL., FINE	FILTRE À AIR CPL., TRÈS FIN	FILTRO DE AIRE CPL., FINO
2	28	1	1	1	1	1	1	1	1	1	1	1				1	181 173 190		LUFTFILTER KPL.	VLIES	AIR FILTER ASS'Y	FILTRE À AIR CPL.	FILTRO DE AIRE CPL.
2	28															1	181 173 180		LUFTFILTER KPL.	VLIES (USA)	AIR FILTER ASS'Y	FILTRE À AIR CPL.	FILTRO DE AIRE CPL.
2	29	1	1	1	1	1	1	1	1	1	1	1	1	1	1	1	181 171 050		KLAMMER FÜR LUFTFILTER		CLIP FOR AIR FILTER	BRIDE DE FIX. P. FILTRE À AIR	GRAPA PARA FILTRO DE AIRE
2	30	1	1	1	1	1	1	1	1	1	1	1	1	1	1	1	010 117 050	TI 2005/13	UMBAUSATZ	INCL. 7	MODIFICATION SET	JEU DE MODIFICATION	JUEGO DE MODIFICACIÓN
2	31	2	2	2	2	2	2	2	2	2	2	2	2	2	2	2	908 505 555		SCHRAUBE INNEN6RD ZK	M5x55	H.L. SOCKET HEAD BOLT	VIS	TORNILLO
2	32	1	1	1	1	1	1	1	1	1	1	1	1	1	1	1	181 155 020		CHOKE/EIN/AUS-HEBEL		CHOKE ON/OFF SWITCH	STARTER/LEVIER MARCHE-ARRÊT	PALANCA ON/OFF / STARTER
2	33	1	1	1	1	1	1	1	1	1	1	1	1	1	1	1	970 311 550		MASSELEITUNG	Messing, Brass	EARTH CABLE	FIL DE MASSE	CONDUCCIÓN A MASA
2	34	1	1	1	1	1	1	1	1	1	1	1	1	1	1	1	913 455 164		INNENSTERN SCHRAUBE	5,5X16	SCREW	VIS	TORNILLO
2	35					1	1										980 115 154		SCHILD, SCHWARZ	SPEED	LABEL, BLACK	PLAQUE	CALCOMANIA
2	36	1	1	1	1	1	1	1	1	1	1	1	1	1	1	1	181 131 603		VERGASERBODEN BLAU KPL.		BOTTOM BLUE	FOND BLEU	FONDO AZUL
2	37	4	4	4	4	4	4	4	4	4	4	4	4	4	4	4	908 805 205		ZYLINDERSCHRAUBE MIT SPANNSCHEIBE	M5X20	SCREW	VIS	TORNILLO
2	38	1	1	1	1	1	1	1	1	1	1	1	1	1	1	1	038 118 110		GUMMIKLAPPE		RUBBER FLAP	CLAPET CAOUTCHOUC	VÁLVULA DE GOMA
2	39	1	1	1	1	1	1	1	1	1	1	1	1	1	1	1	938 650 062		SPREIZNIET		RIVET	RIVET	REMACHE
2	40	1	1	1	1	1	1	1	1	1	1	1	1	1	1	1	181 171 150		VERGASERFLANSCH KPL.		FLANGE KPL.	BRIDE CPL.	BRIDA CPL.
2	41	1	1	1	1	1	1	1	1	1	1	1	1	1	1	1	181 131 090		IMPULSSCHLAUCH		TUBE	GAINE	TUBO
2	42	1	1	1	1	1	1	1	1	1	1	1	1	1	1	1	181 131 040		ANSAUGSCHLAUCH		SUCTION HOSE	TUYAU D' ASPIRATION	TUBO DE ASPIRACIÓN
2	43	1	1	1	1	1	1	1	1	1	1	1	1	1	1	1	181 118 160		EINSATZ SO/WI (SCHNEE)		INSERT (SNOW)	PIÈCE D' INSERTION (NEIGE)	PIEZA DE CIERRE (NIEVE)
2	44	1	1	1	1	1	1	1	1	1	1	1	1	1	1	1	181 131 070		RINGFEDER		ANNULAR SPRING	RESSORT ANNULAIRE	MUELLE DE ANILLO
2	45	1	1	1	1	1	1	1	1	1	1	1	1	1	1	1	913 455 164		INNENSTERN SCHRAUBE	5,5X16	SCREW	VIS	TORNILLO
2	46	1	1	1	1	1	1	1	1	1	1	1	1	1	1	1	181 155 010		KONTAKTFEDER		CONTACT SPRING	RESSORT DE CONTACT	RESORTE DE CONTACTO

DCS460, DCS461, DCS500, DCS501,
 DCS4600S, DCS4600SH, DCS5000,
 DCS5000H, DCS5001, DCS5001H, DCS5121,
 DCS460, DCS510, DCS5121, DE5045

2

Abdeckhaube, Luftfilter, Schalldämpfer
 Hood, air filter, muffler
 Capot protecteur, filtre à air, pot d'échappement
 Cubierta protectora, filtro de aire, silencioso

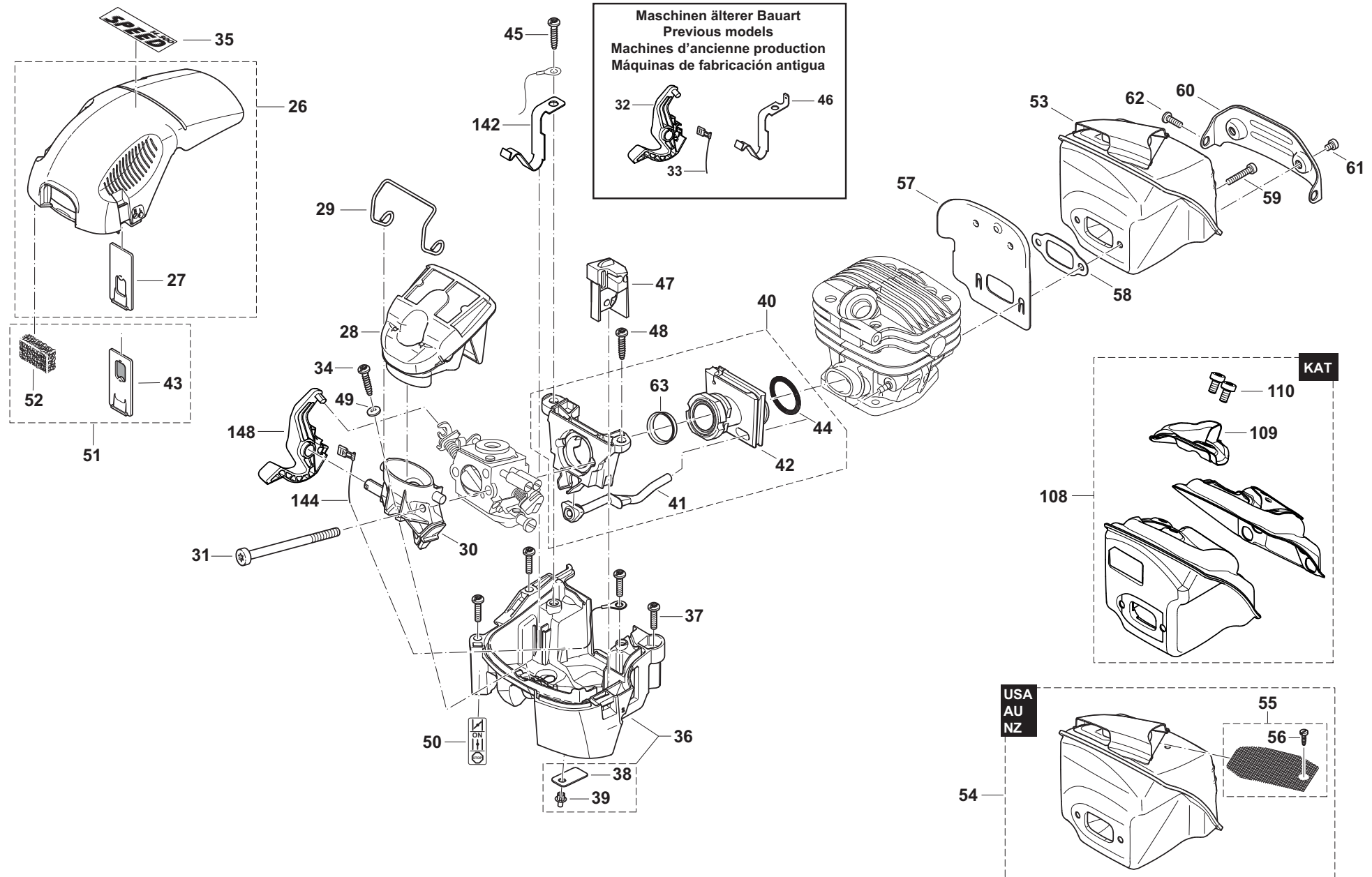

DCS460, DCS461, DCS500, DCS501,
DCS4600S, DCS4600SH, DCS5000,
DCS5000H, DCS5001, DCS5001H, DCS5121,
DCS460, DCS510, DCS5121, DE5045

2

Abdeckhaube, Luftfilter, Schalldämpfer
Hood, air filter, muffler
Capot protecteur, filtre à air, pot d'échappement
Cubierta protectora, filtro de aire, silencioso



Seite / Page	Pos.	DCS460	DCS461	DCS500	DCS501	DCS4600S	DCS4600SH	DCS5000	DCS5000H	DCS5001	DCS5001H	DCS5121	DCS460 (USA)	DCS510 (USA)	DCS5121 (USA)	DE5045	Teil-Nr. Part No. No. de pièce No. de pieza	Hinweise Notes Renseign. Nota	Bezeichnung	Spezifikation Specification	Description	Désignation	Denominación
2	47	1	1	1	1	1	1	1	1	1	1	1	1	1	1	1	181 155 030	=> 2012-03	VERGASER-EINSTELLFÜHRUNG		ADJUSTING GUIDE	GUIDAGE D' AJUSTAGE	GUÍA DE AJUSTE
2	47	1	1	1	1	1	1	1	1	1	1	1	1	1	1	1	181 155 080	2012-04 =>	FÜHRUNG		GUIDE	GUIDAGE	GUÍA
2	48	1	1	1	1	1	1	1	1	1	1	1	1	1	1	1	913 455 164		INNENSTERN SCHRAUBE	5,5X16	SCREW	VIS	TORNILLO
2	49	1	1	1	1	1	1	1	1	1	1	1	1	1	1	1	928 405 000		SPANNSCHEIBE		DISC	DISQUE	ARANDELA
2	50	1	1	1	1	1	1	1	1	1	1	1	1	1	1	1	980 114 928		AUFKLEBER	CHOKE I-0	LABEL	PLAQUE	CALCOMANIA
2	51	1	1	1	1	1	1	1	1	1	1	1	1	1	1	1	957 173 250		SCHNEESET		SNOW FILTER SET	FILTRE A NEIGE JEU	FILTRO DE NIEVE JUEGO
2	52	1	1	1	1	1	1	1	1	1	1	1	1	1	1	1	181 173 250		VORFILTER		PRE-FILTER	PREFILTRE	PRIMER FILTRO
2	53	1	1	1	1	1	1	1	1	1	1					1	181 174 102		SCHALLDÄMPFER KPL.		MUFFLER	POT D' ÉCHAPPEMENT	SILENCIADOR
2	54	1		1						1			1	1			181 174 201		SCHALLDÄMPFER KPL.	AU, NZ	MUFFLER	POT D' ÉCHAPPEMENT	SILENCIADOR
2	55												1	1			181 174 250		FUNKENSCHUTZSIEB KPL.	AU, NZ	SPARK ARRESTER SCREEN CPL.	TAMIS CPL.	TAMIZ CPL.
2	56												1	1			915 035 120		SCHRAUBE		SCREW	VIS	TORNILLO
2	57	1	1	1	1	1	1	1	1	1	1	1	1	1	1	1	181 174 062		ABSCHIRMBLECH		COOLING PLATE	TÔLE DE PROTECTION	CHAPA DEFLECTORA
2	58	1	1	1	1	1	1	1	1	1	1	1	1	1	1	1	181 174 050		DICHTUNG SCHALLDÄMPFER		GASKET	JOINT	JUNTA
2	59	2	2	2	2	2	2	2	2	2	2	2	2	2	2	2	908 005 205		INNENSTERN SCHRAUBE	M5x20	SCREW	VIS	TORNILLO
2	60	1	1	1	1	1	1	1	1	1	1	1	1	1	1	1	181 174 091		HALTEBLECH SCHALLDÄMPFER		SHEET-METAL	TÔLE DE SUPPORT	CHAPA SOPORTE
2	61	2	2	2	2	2	2	2	2	2	2	2	2	2	2	2	908 005 095		SCHRAUBE	M5x9	SCREW	VIS	TORNILLO
2	62	1	1	1	1	1	1	1	1	1	1	1	1	1	1	1	908 805 205		ZYLINDERSCHRAUBE MIT SPANNSCHEIBE	M5X20	SCREW	VIS	TORNILLO
2	63	1	1	1	1	1	1	1	1	1	1	1	1	1	1	1	181 131 021		EINSATZ FÜR ANSAUGSCHLAUCH		INSERT	PIÈCE D' INSERTION	PIEZA DE CIERRE
2	108											1		1			181 174 301	2009-03 =>	SCHALLDÄMPFER KPL.	KAT	MUFFLER	POT D' ÉCHAPPEMENT	SILENCIADOR
2	109											1		1			181 174 470		AUSLASSHUTZE KPL.	KAT	SPARK ARRESTER SCREEN CPL.	TAMIS CPL.	TAMIZ CPL.
2	110											2		2			908 005 095		SCHRAUBE	M5x9	SCREW	VIS	TORNILLO
2	142	1		1								1	1	1		1	181 155 011	2010 =>	KONTAKTFEDER		CONTACT SPRING	RESSORT DE CONTACT	RESORTE DE CONTACTO
2	144	1		1								1	1	1		1	970 311 580	2010 =>	MASSELEITUNG	Stahl, Steel	EARTH CABLE	FIL DE MASSE	CONDUCCIÓN A MASA
2	148	1		1								1	1	1		1	181 155 070	2010 =>	CHOKE/EIN/AUS-HEBEL		CHOKE ON/OFF SWITCH	STARTER/LEVIER MARCHE-ARRÊT	PALANCA ON/OFF / STARTER

DCS460, DCS461, DCS500, DCS501,
DCS4600S, DCS4600SH, DCS5000,
DCS5000H, DCS5001, DCS5001H, DCS5121,
DCS460, DCS510, DCS5121, DE5045

3

Zylinder, Kurbelgehäuse
Cylinder, crankcase
Cylindre, carter-vilebrequin
Cilindro, cárter cigüeñal

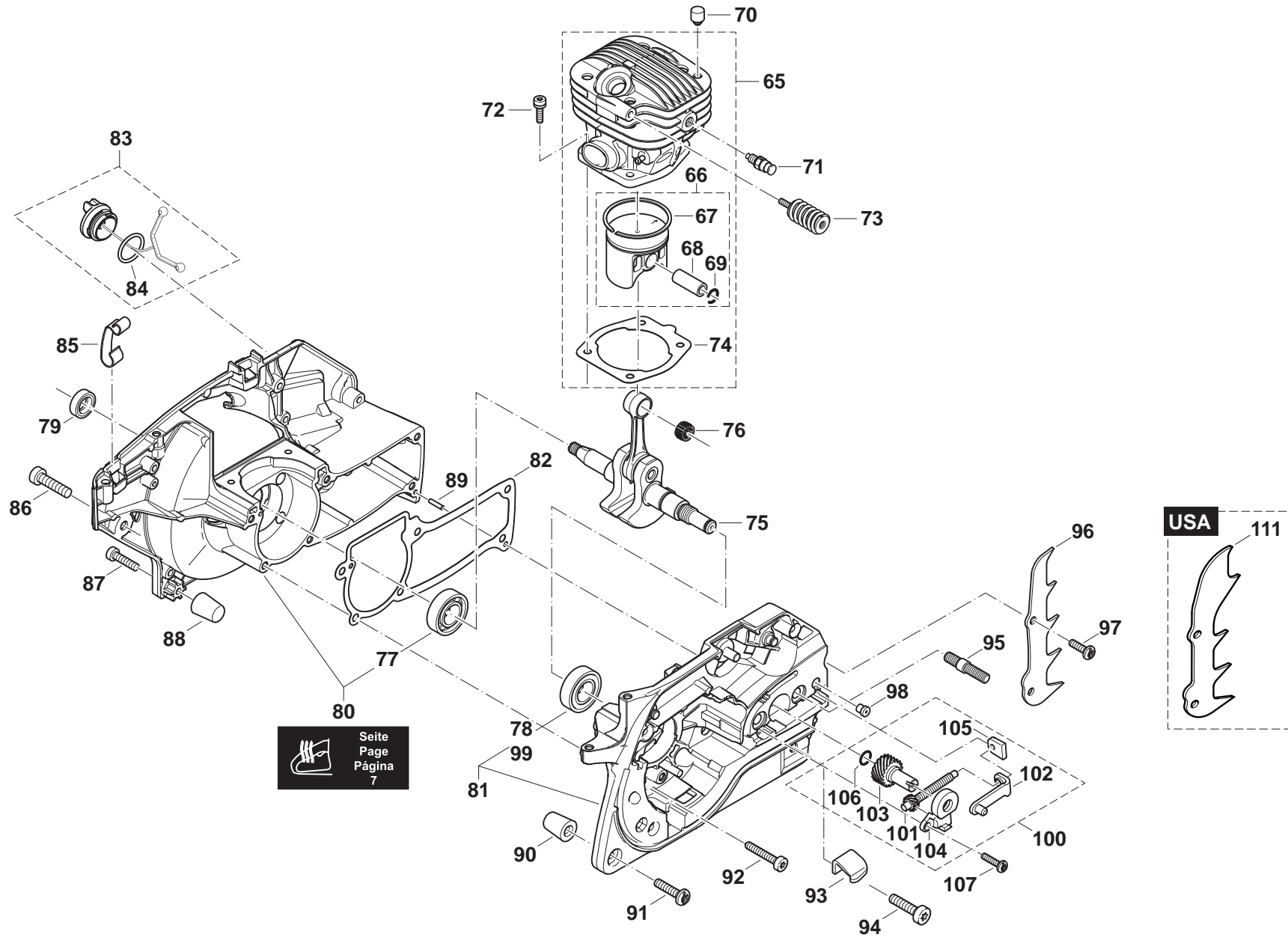

DCS460, DCS461, DCS500, DCS501,
DCS4600S, DCS4600SH, DCS5000,
DCS5000H, DCS5001, DCS5001H, DCS5121,
DCS460, DCS510, DCS5121, DE5045

3

Zylinder, Kurbelgehäuse
Cylinder, crankcase
Cylindre, carter-vilebrequin
Cilindro, cárter cigüeñal



Seite / Page	Pos.	DCS460	DCS461	DCS500	DCS501	DCS4600S	DCS4600SH	DCS5000	DCS5000H	DCS5001	DCS5001H	DCS5121	DCS460 (USA)	DCS510 (USA)	DCS5121 (USA)	DE5045	Teil-Nr. Part No. No. de pièce No. de pieza	Hinweise Notes Renseign. Nota	Bezeichnung	Spezifikation Specification	Description	Désignation	Denominación
3	65	1											1				178 130 214		ZYLINDER / KOLBEN KPL.	D43	CYLINDER / PISTON CPL.	CYLINDRE ET PISTON CPL.	CILINDRO CON PISTÓN CPL.
3	65		1														178 130 252	=> 2009	ZYLINDER / KOLBEN KPL.	Ø 43 DECO	CYLINDER / PISTON CPL.	CYLINDRE ET PISTON CPL.	CILINDRO CON PISTÓN CPL.
3	65			1								1		1			179 130 215	2012-09 =>	ZYLINDER / KOLBEN KPL.	D45	CYLINDER / PISTON CPL.	CYLINDRE ET PISTON CPL.	CILINDRO CON PISTÓN CPL.
3	65				1												179 130 253	=> 2009	ZYLINDER / KOLBEN KPL.	Ø 45 DECO	CYLINDER / PISTON CPL.	CYLINDRE ET PISTON CPL.	CILINDRO CON PISTÓN CPL.
3	65					1	1										180 130 215		ZYLINDER / KOLBEN KPL.	Ø 43	CYLINDER / PISTON CPL.	CYLINDRE ET PISTON CPL.	CILINDRO CON PISTÓN CPL.
3	65							1	1								181 130 217		ZYLINDER / KOLBEN KPL.	Ø 45	CYLINDER / PISTON CPL.	CYLINDRE ET PISTON CPL.	CILINDRO CON PISTÓN CPL.
3	65									1	1						181 130 255	=> 2009	ZYLINDER / KOLBEN KPL.	Ø 45 DECO	CYLINDER / PISTON CPL.	CYLINDRE ET PISTON CPL.	CILINDRO CON PISTÓN CPL.
3	66	1	1			1	1						1				180 132 063		KOLBEN KPL.	Ø 43	PISTON CPL.	PISTON CPL.	PISTÓN CPL.
3	66			1	1			1	1	1	1	1	1	1	1	1	181 132 063		KOLBEN KPL.	D45	PISTON CPL.	PISTON CPL.	PISTÓN CPL.
3	67	1	1			1	1					1					180 132 080		KOLBENRING	Ø 43	PISTON RING	SEGMENT DE PISTON	SEGMENTO DE PISTÓN
3	67			1	1			1	1	1	1	1	1	1	1	1	181 132 080		KOLBENRING	Ø 45	PISTON RING	SEGMENT DE PISTON	SEGMENTO DE PISTÓN
3	68	1	1	1	1	1	1	1	1	1	1	1	1	1	1	1	181 132 090		KOLBENBOLZEN		PISTON PIN	AXE DE PISTON	PERNO DE PISTÓN
3	69	2	2	2	2	2	2	2	2	2	2	2	2	2	2	2	181 132 050		SPRENGRING	C 12X1	SPRING RING	ANNEAU-RESSORT	ANILLO ELÁSTICO
3	70	2	2	2	2	2	2	2	2	2	2	2	2	2	2	2	181 118 070		DÄMPFUNGSSTOPFEN		DAMPING PLUG	TAMPON	TAPÓN DE AMORTIGUACIÓN
3	71		1		1					1	1						001 131 150	=> 2009	DEKOMPRESSIVVENTIL		VALVE	SOUPAPE	VÁLVULA
3	72	4	4	4	4	4	4	4	4	4	4	4	4	4	4	4	908 805 235		INNENSTERNSCHRAUBE MIT SPANNSCHEIBE	M5x23	SCREW	VIS	TORNILLO
3	73	1	1	1	1	1	1	1	1	1	1	1	1	1	1	1	181 114 401		DÄMPFUNGSFEDER KPL.		DAMPING SPRING, CPL.	RESSORT D'AMORTISS. CPL.	MUELLE DE AMORTIGUACIÓN CPL.
3	74	1	1	1	1	1	1	1	1	1	1	1	1	1	1	1	181 131 132	2008-03 =>	ZYLINDERFUßDICHTUNG		GASKET	JOINT	JUNTA
3	74	1	1	1	1	1	1	1	1	1	1	1	1	1	1	1	181 131 131	=> 2008-02	ZYLINDERFUßDICHTUNG, METALL		GASKET, METAL	JOINT, MÉTAL	JUNTA, METAL
3	75	1	1	1	1	1	1	1	1	1	1	1	1	1	1	1	181 120 100		KURBELWELLE KPL.		CRANKSHAFT CPL.	VILEBREQUIN CPL.	CIGÜEÑAL CPL.
3	75	1		1								1	1	1	1	1	181 120 102	2010-03 =>	KURBELWELLE KPL.		CRANKSHAFT CPL.	VILEBREQUIN CPL.	CIGÜEÑAL CPL.
3	76	1	1	1	1	1	1	1	1	1	1	1	1	1	1	1	962 210 033		NADELKÄFIG	10x13x12,5	NEEDLE CAGE	CAGE À AIGUILLES	JAULA DE AGUJAS
3	77	1	1	1	1	1	1	1	1	1	1	1	1	1	1	1	960 102 159		KUGELLAGER (EINKLEBEN)	6202	BALL BEARING (USE GLUE)	ROULEMENT À BILLES (À COLLER)	RODAM. DE BOLAS (A COLAR)
3	78	1	1	1	1	1	1	1	1	1	1	1	1	1	1	1	960 123 159		KOMBIKUGELLAGER	6202 C3	COMBINATION BALL BEARING	ROULEMENT À BILLES COMBINÉ	RODAMIENTO COMBI
3	79	1	1	1	1	1	1	1	1	1	1	1	1	1	1	1	962 900 156		RADIALDICHTRING	Ø 12/20x4,5	RADIAL RING	JOINT RADIAL	ANILLO RADIAL
3	80	1	1	1	1							1	1	1	1		179 111 653		KURBELGEHÄUSE MS BLAU	Al	CRANKC. M. SIDE BLUE	CARTER-COTÉ MA. BLEU	CÁRTER CIG. LADO MA. AZUL
3	80					1	1	1	1	1						1	181 111 655		KURBELGEHÄUSE MS BLAU	Mg	CRANKC. M. SIDE BLUE	CARTER-COTÉ MA. BLEU	CÁRTER CIG. LADO MA. AZUL

DCS460, DCS461, DCS500, DCS501,
DCS4600S, DCS4600SH, DCS5000,
DCS5000H, DCS5001, DCS5001H, DCS5121,
DCS460, DCS510, DCS5121, DE5045

3

Zylinder, Kurbelgehäuse
Cylinder, crankcase
Cylindre, carter-vilebrequin
Cilindro, cárter cigüeñal

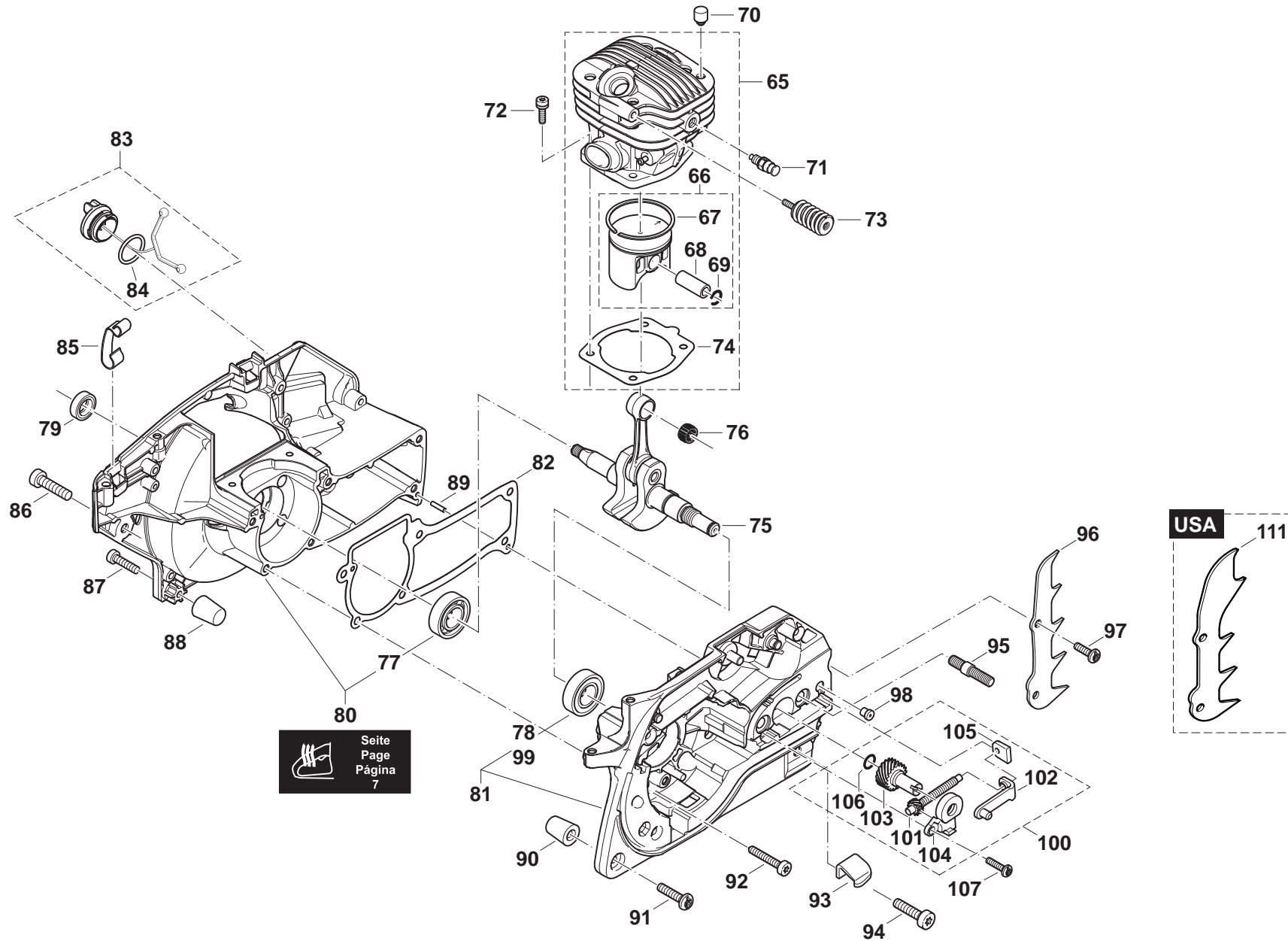

Seite
Page
Página
7

DCS460, DCS461, DCS500, DCS501,
DCS4600S, DCS4600SH, DCS5000,
DCS5000H, DCS5001, DCS5001H, DCS5121,
DCS460, DCS510, DCS5121, DE5045

3

Zylinder, Kurbelgehäuse
Cylinder, crankcase
Cylindre, carter-vilebrequin
Cilindro, cárter cigüeñal



Seite / Page	Pos.	DCS460	DCS461	DCS500	DCS501	DCS4600S	DCS4600SH	DCS5000	DCS5000H	DCS5001	DCS5001H	DCS5121	DCS460 (USA)	DCS510 (USA)	DCS5121 (USA)	DE5045	Teil-Nr. Part No. No. de pièce No. de pieza	Hinweise Notes Renseign. Nota	Bezeichnung	Spezifikation Specification	Description	Désignation	Denominación
3	81	1	1	1	1							1	1	1	1		179 111 641		KURBELGEHÄUSE KS BLAU	AI	CRANKC. CL. SIDE BLUE	CARTER-COTÉ EM. BLEU	CÁRTER CIG. LADO EM. AZUL
3	81					1	1	1	1	1	1					1	181 111 642		KURBELGEHÄUSE KS BLAU	Mg	CRANKC. CL. SIDE BLUE	CARTER-COTÉ EM. BLEU	CÁRTER CIG. LADO EM. AZUL
3	82	1	1	1	1	1	1	1	1	1	1	1	1	1	1	1	181 111 060		KURBELGEHÄUSEDICHTUNG		GASKET	JOINT	JUNTA
3	83	1	1	1	1	1	1	1	1	1	1	1	1	1	1	1	170 114 100		TANKDECKEL KPL.		TANK CAP COMPLETE	BOUCHON RESERVOIR CPL.	TORNILLO DE CIERRE CPL.
3	84	1	1	1	1	1	1	1	1	1	1	1	1	1	1	1	963 225 030		O-RING		PACKING RING	BAGUE-JOINT	ANILLO DE GUARNICION
3	85	3	3	3	3	3	3	3	3	3	3	3	3	3	3	3	181 118 050		HAUBENKLAMMER		STEELCLIP	AGRAFE	PINZA DE ACERO
3	86	1	1	1	1	1	1	1	1	1	1	1	1	1	1	1	908 006 205		INNENSTERN-SCHRAUBE	M6x20	SCREW	VIS	TORNILLO
3	87	1	1	1	1	1	1	1	1	1	1	1	1	1	1	1	908 805 205		ZYLINDERSCHRAUBE MIT SPANNSCHEIBE	M5X20	SCREW	VIS	TORNILLO
3	88	1	1	1	1	1	1	1	1	1	1	1	1	1	1	1	181 111 230		ANSCHLAGDÄMPFER		IMPACT PROTECTION	AMORTISSEUR DE BUTÉE	AMORTIGUADOR DE TOPE
3	89	2	2	2	2	2	2	2	2	2	2	2	2	2	2	2	936 430 160		SPIRALSPANNSTIFT	3X16	CLAMPING PIN	GOUPILLE	PASADOR
3	90	1	1	1	1	1	1	1	1	1	1	1	1	1	1	1	181 111 230		ANSCHLAGDÄMPFER		IMPACT PROTECTION	AMORTISSEUR DE BUTÉE	AMORTIGUADOR DE TOPE
3	91	1	1	1	1	1	1	1	1	1	1	1	1	1	1	1	908 805 205		ZYLINDERSCHRAUBE MIT SPANNSCHEIBE	M5X20	SCREW	VIS	TORNILLO
3	92	6	6	6	6	6	6	6	6	6	6	6	6	6	6	6	908 005 205		INNENSTERN SCHRAUBE	M5x20	SCREW	VIS	TORNILLO
3	93	1	1	1	1	1	1	1	1	1	1	1	1	1	1	1	181 111 050		KETTENFÄNGER		CHAIN CATCH	ARRÊTE-CHAÎNE	BULÓN DE RETENCIÓN
3	94	1	1	1	1	1	1	1	1	1	1	1	1	1	1	1	908 006 205		INNENSTERN-SCHRAUBE	M6x20	SCREW	VIS	TORNILLO
3	95	2	2	2	2	2	2	2	2	2	2	2	2	2	2	2	905 808 210		STIFTSCHRAUBE	M8x21	SCREW	VIS	TORNILLO
3	96	1	1	1	1	1	1	1	1	1	1	1	1	1	1	1	181 250 011		ZACKENLEISTE		SPIKE BAR	BARRE DENTÉE	BARRA DENTADA
3	97	2	2	2	2	2	2	2	2	2	2	2	2	2	2	2	908 805 205		ZYLINDERSCHRAUBE MIT SPANNSCHEIBE	M5X20	SCREW	VIS	TORNILLO
3	98	1	1	1	1	1	1	1	1	1	1	1	1	1	1	1	010 245 030		BELÜFTUNGSVENTIL		VENT VALVE	SOUPAPE D AERATION	VALVULA VENTILACION
3	99	1	1	1	1	1	1	1	1	1	1	1	1	1	1	1	962 900 065		RADIALDICHTRING		RADIAL RING	JOINT RADIAL	JUNTA RADIAL
3	100	1	1	1	1	1	1	1	1	1	1	1	1	1	1	1	181 213 300		KETTENSPELLER KPL.	PROFI	CHAIN TENSIONER CPL.	TENDEUR DE CHAÎNE CPL.	SENSOR DE LA CADENA CPL.
3	101	1	1	1	1	1	1	1	1	1	1	1	1	1	1	1	181 213 230		KETTENSPELLERSCHRAUBE	PROFI	TENSIONING SCREW	VIUS DE TENSION	TORNILLO DE TENSION
3	102	1	1	1	1	1	1	1	1	1	1	1	1	1	1	1	181 213 240		SPANNSCHLITTEN	PROFI	TENSION SLIDE	COULISSEAU DE SERRAGE	CARRO DE TENSADO
3	103	1	1	1	1	1	1	1	1	1	1	1	1	1	1	1	181 213 250		EINSTELLSCHRAUBE	PROFI	ADJUSTING SCREW	VIS DE REGLAGE	TORNILLO DE AJUSTE
3	104	1	1	1	1	1	1	1	1	1	1	1	1	1	1	1	181 213 270		GETRIEBEABDECKUNG	PROFI	TRANSMISSION COVER	REVÊTEMENT D' ENGRENAGES	CUBIERTA DE ENGRANAJES
3	105	1	1	1	1	1	1	1	1	1	1	1	1	1	1	1	181 213 260		SPANNSCHRAUBENLAGER		TENSIONING SCREW BEARING	PALIER DE LA VIS DE TENSION	SOPORTE DEL TORNILLO SENSOR
3	106	1	1	1	1	1	1	1	1	1	1	1	1	1	1	1	963 207 020		O-RING	7X2	PACKING RING	BAGUE-JOINT	ANILLO DE GUARNICION
3	107	1	1	1	1	1	1	1	1	1	1	1	1	1	1	1	908 705 125		SCHRAUBE	M5x12	SCREW	VIS	TORNILLO
3	111															1	181 250 020		ZACKENLEISTE	US	SPIKE BAR	BARRE DENTÉE	BARRA DENTADA

DCS460, DCS461, DCS500, DCS501,
DCS4600S, DCS4600SH, DCS5000,
DCS5000H, DCS5001, DCS5001H, DCS5121,
DCS460, DCS510, DCS5121, DE5045

4

Zündelektronik, Anwerfvorrichtung
Ignition electronics, starter
Allumage électronique, dispositif de démarrage
Bobina encendido, dispositivo de arranque

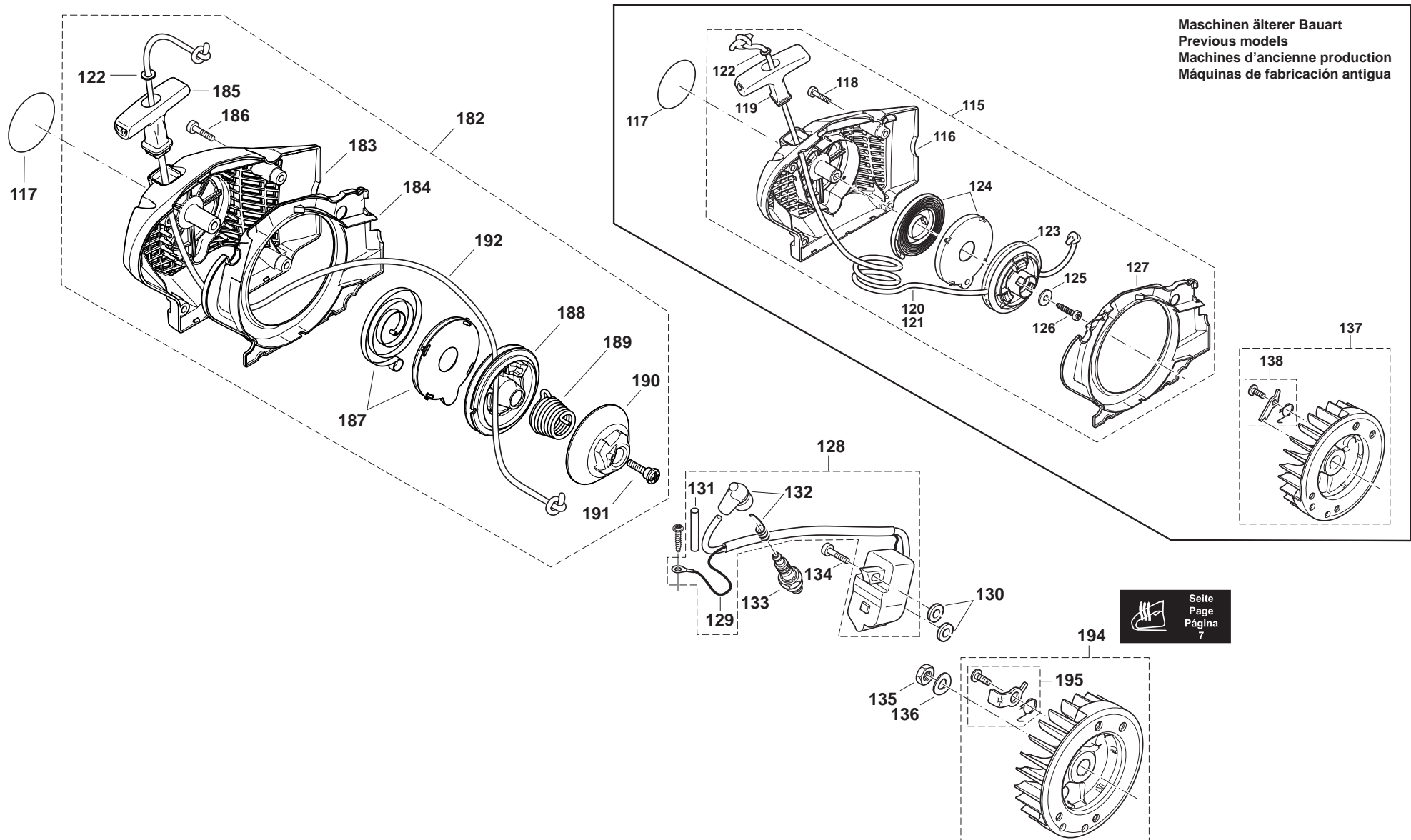

DCS460, DCS461, DCS500, DCS501,
DCS4600S, DCS4600SH, DCS5000,
DCS5000H, DCS5001, DCS5001H, DCS5121,
DCS460, DCS510, DCS5121, DE5045

4

Zündelektronik, Anwerfvorrichtung
Ignition electronics, starter
Allumage électronique, dispositif de démarrage
Bobina encendido, dispositivo de arranque



Seite / Page	Pos.	DCS460	DCS461	DCS500	DCS501	DCS4600S	DCS4600SH	DCS5000	DCS5000H	DCS5001	DCS5001H	DCS5121	DCS460 (USA)	DCS510 (USA)	DCS5121 (USA)	DE5045	Teil-Nr. Part No. No. de pièce No. de pieza	Hinweise Notes Renseign. Nota	Bezeichnung	Spezifikation Specification	Description	Désignation	Denominación
4	115	1	1	1	1	1	1	1	1	1	1	1	1	1	1	1	181 160 601		ANWERFVORRICHTUNG KPL. BLAU		STARTER ASSY. BLUE	DISPOS. DE DÉMARRAGE CPL. BLEU	DISPOS. DE ARRANQUE CPL. AZUL
4	116	1	1	1	1	1	1	1	1	1	1	1	1	1	1	1	181 112 621		VENTILATORGEHÄUSE BLAU		FAN HOUSING BLUE	CARTER DE VENTILATEUR	CÁRTER DE VENTILADOR AZUL
4	117	1											1				980 115 222		SCHILD VENTILATORGEHÄUSE	DCS460	LABEL	PLAQUE	CALCOMANIA
4	117		1														980 115 223		SCHILD VENTILATORGEHÄUSE	DCS461	LABEL	PLAQUE	CALCOMANIA
4	117			1													980 115 220		SCHILD VENTILATORGEHÄUSE	DCS500	LABEL	PLAQUE	CALCOMANIA
4	117										1				1		980 115 479		SCHILD VENTILATORGEHÄUSE	DCS5121	LABEL	PLAQUE	CALCOMANIA
4	117				1												980 115 221		SCHILD VENTILATORGEHÄUSE	DCS501	LABEL	PLAQUE	CALCOMANIA
4	117					1	1										980 115 218		SCHILD VENTILATORGEHÄUSE	DCS4600	LABEL	PLAQUE	CALCOMANIA
4	117							1	1								980 115 216		SCHILD VENTILATORGEHÄUSE	DCS5000	LABEL	PLAQUE	CALCOMANIA
4	117									1	1						980 115 217		SCHILD VENTILATORGEHÄUSE	DCS5001	LABEL	PLAQUE	CALCOMANIA
4	117												1				980 115 224		SCHILD VENTILATORGEHÄUSE	DCS510	LABEL	PLAQUE	CALCOMANIA
4	117														1		980 115 198		SCHILD VENTILATORGEHÄUSE	DE5045	LABEL	PLAQUE	CALCOMANIA
4	118	4	4	4	4	4	4	4	4	4	4	4	4	4	4	4	908 805 205		ZYLINDERSCHRAUBE MIT SPANNSCHEIBE	M5X20	SCREW	VIS	TORNILLO
4	119	1	1	1	1	1	1	1	1	1	1	1	1	1	1	1	001 161 020		ANWERFGRIF		STARTER GRIP	POIGNÉE DE LANCEMENT	TIRADOR DE ARRANQUE
4	120	1	1	1	1	1	1	1	1	1	1	1	1	1	1	1	108 164 020		ANWERFSEIL	∅ 3,5 x 980 mm	STARTER ROPE	CÂBLE DE DÉMARRAGE	CORDÓN DE ARRANQUE
4	121	1	1	1	1	1	1	1	1	1	1	1	1	1	1	1	985 000 155	ACC.	ANWERFSEIL	∅ 3,5 x 100 m	STARTER ROPE	CORDE DE LANCEUR	CUERDA DE ARRANQUE
4	122	1	1	1	1	1	1	1	1	1	1	1	1	1	1	1	928 405 000		SPANNSCHEIBE		DISC	DISQUE	ARANDELA
4	123	1	1	1	1	1	1	1	1	1	1	1	1	1	1	1	181 162 150		SEILTROMMEL KPL.		CABLE DRUM CPL.	TAMBOUR DE CÂBLE CPL.	TAMBOUR PARA CORDÓN CPL.
4	124	1	1	1	1	1	1	1	1	1	1	1	1	1	1	1	181 163 020		RÜCKHOLFEDER KPL.		REWIND SPRING IN HOUSING	RESSORT RAPPEL DANS BOÎT	RESORTE RETENC. EN CAJA
4	125	1	1	1	1	1	1	1	1	1	1	1	1	1	1	1	924 605 510		SCHEIBE	∅ 5,5x18x1,6	WASHER	RONDELLE	ARANDELA
4	126	1	1	1	1	1	1	1	1	1	1	1	1	1	1	1	913 455 204		SCHRAUBE	5,5x20	SCREW	VIS	TORNILLO
4	127	1	1	1	1	1	1	1	1	1	1	1	1	1	1	1	181 118 041		LUFTFÜHRUNG		AIR GUIDE PLATE	GUIDE D'AIR	CONDUCTO DE AIRE
4	128	1	1	1	1	1	1	1	1	1	1	1	1	1	1	1	181 143 204		ZÜNDSPULE ROT KPL.		IGNITION COIL, CPL., RED	BOBINE D'ALLUM. CPL. ROUGE	BOBINA DE ENCEN. CPL. ROJO
4	128	1		1								1	1	1		1	181 143 205	2010-03 =>	ZÜNDSPULE SCHWARZ KPL.		IGNITION COIL, CPL., BLACK	BOBINE D'ALLUM. CPL. NOIR	BOBINA DE ENCEN. CPL. NEGRO
4	129	1	1	1	1	1	1	1	1	1	1	1	1	1	1	1	181 147 050		KURZSCHLUSSKABEL		IGNITION CABLE	CÂBLE D'ALLUMAGE	CABLE CORTO-CIRC.

DCS460, DCS461, DCS500, DCS501,
DCS4600S, DCS4600SH, DCS5000,
DCS5000H, DCS5001, DCS5001H, DCS5121,
DCS460, DCS510, DCS5121, DE5045

4

Zündelektronik, Anwerfvorrichtung
Ignition electronics, starter
Allumage électronique, dispositif de démarrage
Bobina encendido, dispositivo de arranque

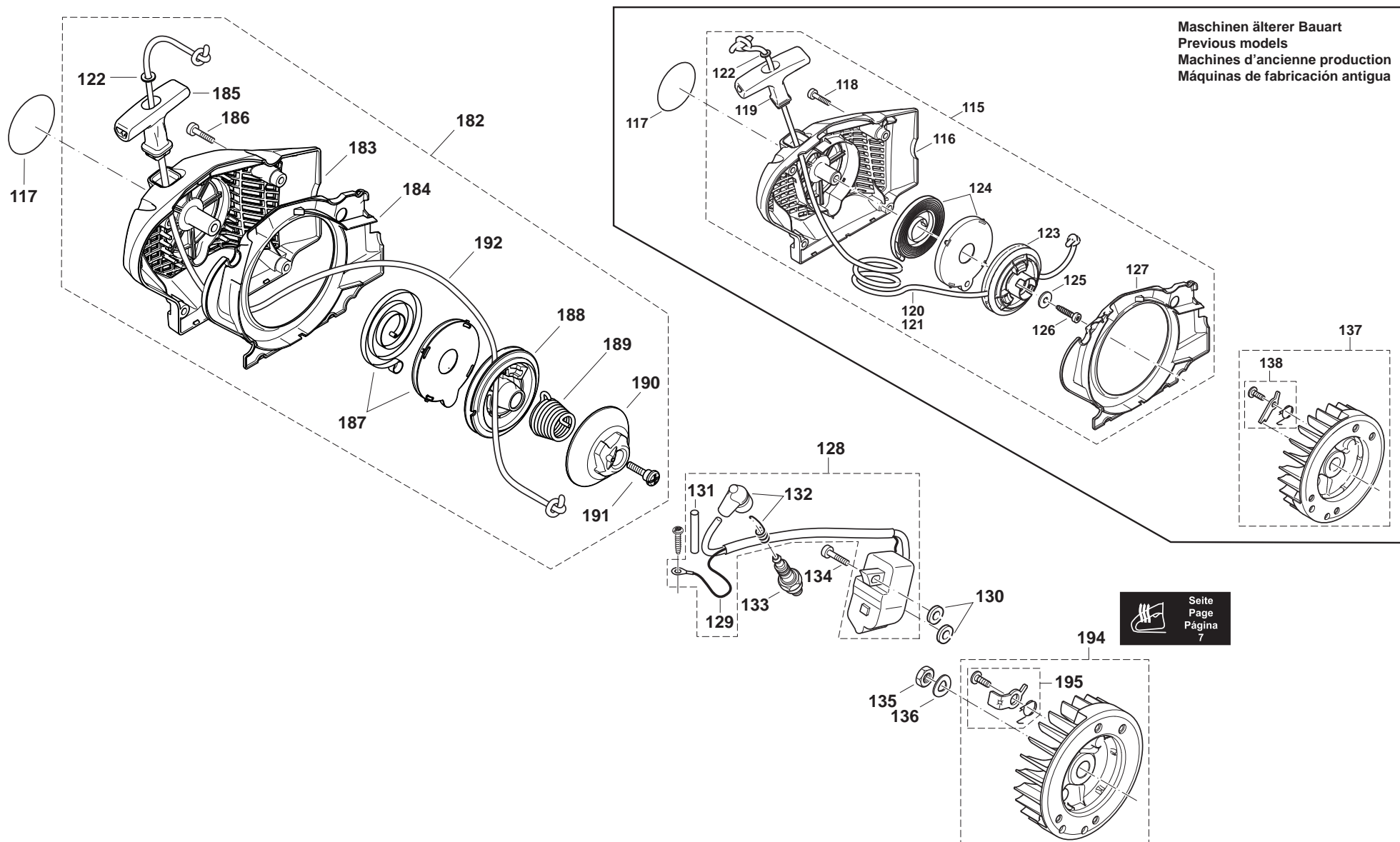

DCS460, DCS461, DCS500, DCS501,
DCS4600S, DCS4600SH, DCS5000,
DCS5000H, DCS5001, DCS5001H, DCS5121,
DCS460, DCS510, DCS5121, DE5045

4

Zündelektronik, Anwerfvorrichtung
Ignition electronics, starter
Allumage électronique, dispositif de démarrage
Bobina encendido, dispositivo de arranque



Seite / Page	Pos.	DCS460	DCS461	DCS500	DCS501	DCS4600S	DCS4600SH	DCS5000	DCS5000H	DCS5001	DCS5001H	DCS5121	DCS460 (USA)	DCS510 (USA)	DCS5121 (USA)	DE5045	Teil-Nr. Part No. No. de pièce No. de pieza	Hinweise Notes Renseign. Nota	Bezeichnung	Spezifikation Specification	Description	Désignation	Denominación
4	130	2	2	2	2	2	2	2	2	2	2	2	2	2	2	2	195 143 030		ISOLIERSCHEIBE	black	ISOLATING WASHER	RONDELLE	ARANDELA
4	131	m	m	m	m	m	m	m	m	m	m	m	m	m	m	m	970 502 110		ISOLIERSCHLAUCH	A6X0,5 L=55mm	ISOLATING HOSE	TUYAU ISOLANT	MANGO AISLANTE
4	132	1	1	1	1	1	1	1	1	1	1	1	1	1	1	1	957 604 260		ZÜNDKERZENSTECKER KPL.		SPARK PLUG CAP CPL.	FICHE DE BOUGIE, CPL.	TAPA DE BUJIA CPL.
4	133	1	1	1	1	1	1	1	1	1	1	1	1	1	1	1	965 603 021		ZÜNDKERZE		SPARK PLUG	BOUGIE	BUJÍA
4	134	2	2	2	2	2	2	2	2	2	2	2	2	2	2	2	908 805 205		ZYLINDERSCHRAUBE MIT SPANNSCHEIBE	M5X20	SCREW	VIS	TORNILLO
4	135	1	1	1	1	1	1	1	1	1	1	1	1	1	1	1	920 308 024		6KT-MUTTER	M8x1	HEXAGONAL NUT	ECROU HEXAGONAL	TUERCA HEXAGONAL
4	136	1	1	1	1	1	1	1	1	1	1	1	1	1	1	1	926 208 001		FEDERSCHEIBE	B8	SPRING WASHER	RONDELLE ÉLASTIQUE	DISCO AMORTIGUADOR
4	137	1	1	1	1	1	1	1	1	1	1	1	1	1	1	1	181 141 104		POLRAD KPL.		FLYWHEEL CPL.	ROUE POLAIRE CPL.	VOLANTE ENCEND. CPL.
4	138	2	2	2	2	2	2	2	2	2	2	2	2	2	2	2	181 166 050		ANWERFKLINKE KPL.		STARTER RATCHET CPL.	CLIQUET CPL.	TRINQUETE ARRANQUE CPL.
4	182	1	1									1	1	1	1	1	181 160 655		ANWERFVORRICHTUNG BLAU KPL.	FARMER	STARTER ASSY. BLUE	DISPOS. DE DÉMARRAGE CPL.	DISPOS. DE ARRANQUE CPL. AZUL
4	183	1	1									1	1	1	1	1	181 112 660		STARTERGEHÄUSE BLAU		STARTER ASSY. BLUE	DISPOS. DE DÉMARRAGE CPL.	DISPOS. DE ARRANQUE CPL. AZUL
4	184	1	1									1	1	1	1	1	181 118 041		LUFTFÜHRUNG		AIR GUIDE PLATE	GUIDE D'AIR	CONDUCTO DE AIRE
4	185	1	1	1								1	1	1	1	1	181 164 010		ANWERFGRIFF		STARTER KNOB	POIGNEE DE LANCEMENT	TIRADOR DE ARRANQUE
4	186	4	4									4	4	4	4	4	908 605 205		SCHRAUBE INNEN6RD	M5x20	SCREW	VIS	TORNILLO
4	187	1	1									1	1	1	1	1	181 163 050		RÜCKHOLFEDER IM GEHÄUSE		REWIND SPRING IN HOUSING	RESSORT RAPPEL DANS BOÎT	RESORTE RETENC. EN CAJA
4	188	1	1									1	1	1	1	1	181 162 020		SEILTROMMEL		CABLE DRUM	TAMBOUR DE CÂBLE	TAMBOUR PARA CORDÓN
4	189	1	1									1	1	1	1	1	181 163 080		FEDER FÜR LEICHTSTART		SPRING EASY-START	RESSORT DE RAPPEL	RESORTE RETENCIÓN
4	190	1	1									1	1	1	1	1	181 163 090		MITNEHMER		DRIVER FOR EASY-START	PIECE D'ENTRAÎNEMENT	ANILLO DE ARRASTRE
4	191	1	1									1	1	1	1	1	181 163 095		SCHRAUBE		SCREW	VIS	TORNILLO
4	192	1	1									1	1	1	1	1	181 164 020		ANWERFSEIL	ø 3,5 x 1100 mm	STARTER ROPE	CORDE DE LANCEUR	CUERDA DE ARRANQUE
4	192	1	1									1	1	1	1	1	985 000 155		ANWERFSEIL	ø 3,5 x 100 m	STARTER ROPE	CORDE DE LANCEUR	CUERDA DE ARRANQUE
4	194	1	1									1	1	1	1	1	195 141 103		POLRAD KPL.		FLYWHEEL CPL.	ROUE POLAIRE CPL.	VOLANTE ENCEND. CPL.
4	195	1	1									1	1	1	1	1	195 166 100		ANWERFKLINKE KPL.		STARTER RATCHET CPL.	CLIQUET CPL.	TRINQUETE ARRANQUE CPL.

DCS460, DCS461, DCS500, DCS501,
DCS4600S, DCS4600SH, DCS5000,
DCS5000H, DCS5001, DCS5001H, DCS5121,
DCS460, DCS510, DCS5121, DE5045

5

Ölpumpe, Kupplung, Kettenbremse
Oil pump, clutch, chain brake
Pompe à huile, embrayage, frein de chaîne
Bomba de aceite, engrague, freno de cadena

Makita

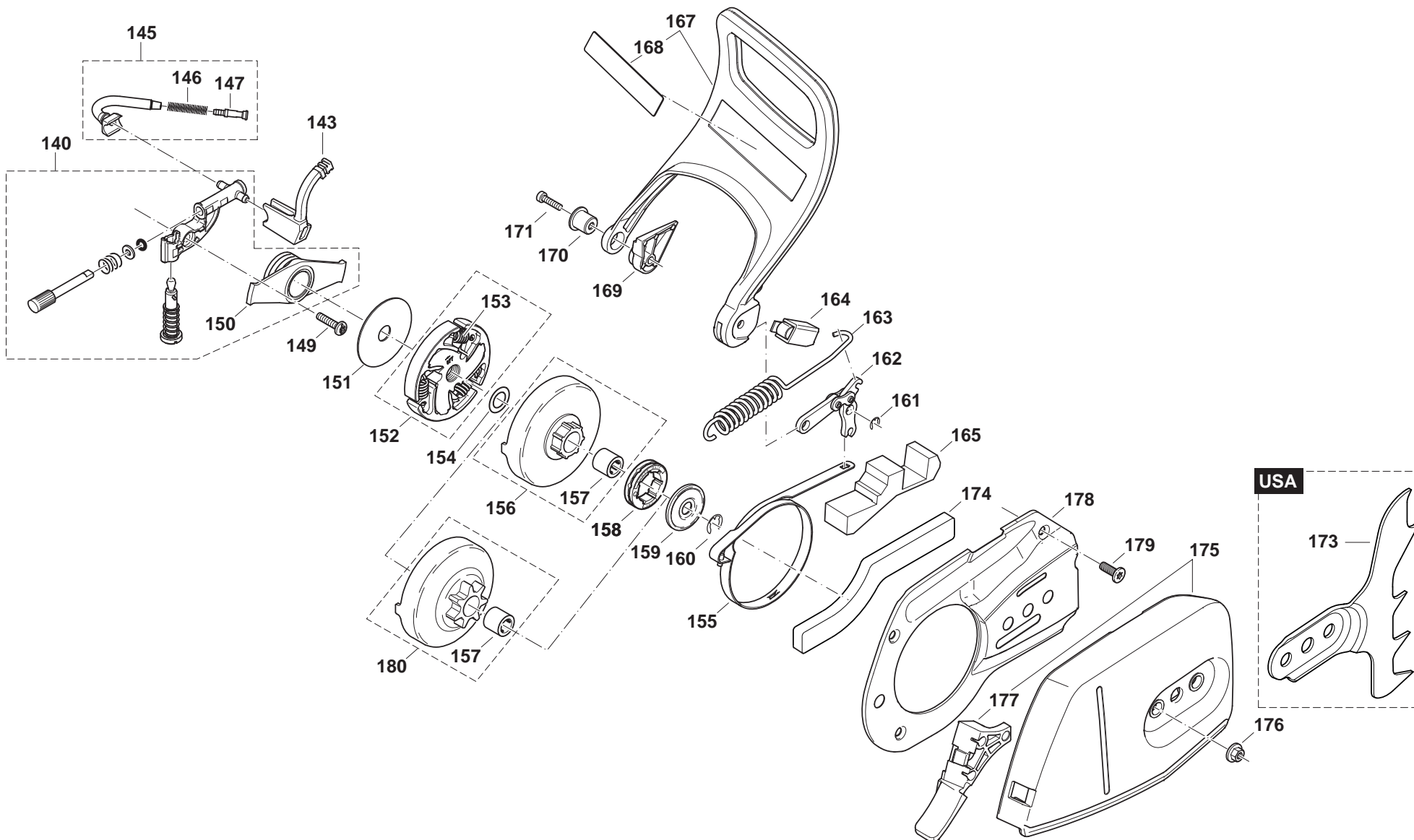

DCS460, DCS461, DCS500, DCS501,
DCS4600S, DCS4600SH, DCS5000,
DCS5000H, DCS5001, DCS5001H, DCS5121,
DCS460, DCS510, DCS5121, DE5045

5

Ölpumpe, Kupplung, Kettenbremse
Oil pump, clutch, chain brake
Pompe à huile, embrayage, frein de chaîne
Bomba de aceite, engrague, freno de cadena



Seite / Page	Pos.	DCS460	DCS461	DCS500	DCS501	DCS4600S	DCS4600SH	DCS5000	DCS5000H	DCS5001	DCS5001H	DCS5121	DCS460 (USA)	DCS510 (USA)	DCS5121 (USA)	DE5045	Teil-Nr. Part No. No. de pièce No. de pieza	Hinweise Notes Renseign. Nota	Bezeichnung	Spezifikation Specification	Description	Désignation	Denominación
5	140	1	1	1	1	1	1	1	1	1	1	1	1	1	1	1	181 245 251		ÖLPUMPE KPL.		OIL PUMP CPL.	POMPE À HUILE CPL.	BOMBA DE ACEITE CPL.
5	143	1	1	1	1	1	1	1	1	1	1	1	1	1	1	1	181 245 120		ÖLDRUCKLEITUNG		PRESSURE LINE	CONDUITE HUILE	TUBO ACEITE
5	145	1	1	1	1	1	1	1	1	1	1	1	1	1	1	1	181 245 100		ÖLSAUGLEITUNG KPL.		SUCTION LINE	CONDUITE HUILE CPL.	TUBO ACEITE CPL.
5	146	1	1	1	1	1	1	1	1	1	1	1	1	1	1	1	021 245 060		DRUCKFEDER		SPRING	RESSORT	MUELLE
5	147	1	1	1	1	1	1	1	1	1	1	1	1	1	1	1	001 245 020		NIPPEL		HOSE STEM	TETON DE TUYAU	BOQUILLA DE TUBO
5	149	1	1	1	1	1	1	1	1	1	1	1	1	1	1	1	908 705 125		SCHRAUBE	M5x12	SCREW	VIS	TORNILLO
5	150	1	1	1	1	1	1	1	1	1	1	1	1	1	1	1	181 245 090		ÖLPUMPENANTRIEB		PUMP DRIVE	LE COMMANDE DE POMPE	PROPULSOR DE LA BOMBA
5	151	1	1	1	1	1	1	1	1	1	1	1	1	1	1	1	001 182 042		FÜHRUNGSSCHEIBE	44,5x1x12	DISC	DISQUE	DISCO
5	152	1	1	1	1	1	1	1	1	1	1	1	1	1	1	1	181 180 200		KUPPLUNG KPL.		CLUTCH ASSY.	EMBRAYAGE CPL.	EMBRAGUE CPL.
5	153	3	3	3	3	3	3	3	3	3	3	3	3	3	3	3	181 184 010		ZUGFEDER FÜR KUPPLUNG		SPRING	RESSORT	RESORTE
5	154	1	1	1	1	1	1	1	1	1	1	1	1	1	1	1	181 224 090		ANLAUFSCHLEIBE	10x18x0,5	SHIM	DISQUE DE DISTANCE	DISCO DE TOPE
5	155	1	1	1	1	1	1	1	1	1	1	1	1	1	1	1	181 213 011		BREMSBAND		BRAKE SPRING	RESSORT DE FREIN	CINTA DE FRENO
5	156			1		1	1	1	1	1	1					1	181 223 062		KUPPLUNGSTROMMEL KPL.	SMALL	CLUTCH DRUM CPL.	TAMBOUR CPL.	TAMBOR CPL.
5	157	1	1	1	1	1	1	1	1	1	1	1	1	1	1	1	962 300 009		NADELHÜLSE	10/14X12	NEEDLE SLEEVER	DOUILLE D'AIGUILLE	CASQUILLO DE AGUJA
5	158					1	1	1	1	1	1					1	181 224 040		ZAHNKRANZ	325", Z=7, SM	RIM SPROCKET	PIGNON A GAGUE	CORONA PIÑON
5	158	1		1		1	1	1	1	1	1					1	026 224 010		ZAHNKRANZ	3/8", Z=7, SM	RIM SPROCKET	PIGNON A GAGUE	CORONA PIÑON
5	159	1	1	1	1	1	1	1	1	1	1	1	1	1	1	1	181 224 081		TOPFSCHLEIBE		DISC	DISQUE	ARANDELA
5	160	1	1	1	1	1	1	1	1	1	1	1	1	1	1	1	927 408 000		SICHERUNGSSCHLEIBE	D=8X1,3	WASHER	RONDELLE	ARANDELA
5	161	1	1	1	1	1	1	1	1	1	1	1	1	1	1	1	927 304 000		SICHERUNGSSCHLEIBE		SAFETY WASHER	RONDELLE SÉCURITÉ	ARANDELA SEGURIDAD
5	162	1	1	1	1	1	1	1	1	1	1	1	1	1	1	1	181 213 100		BREMSMECHANIK KPL.		BRAKING MECHANISM	MECANISME DE FREINAGE	MECANISMO DE FRENO
5	163	1	1	1	1	1	1	1	1	1	1	1	1	1	1	1	181 213 022		ZUGFEDER		TENSION SPRING	RESSORT DE TRACTION	MUELLE DE TRACCIÓN
5	164	1	1	1	1	1	1	1	1	1	1	1	1	1	1	1	181 213 170		KULISSE FÜR HANDSCHUTZ KPL.		HANDGUARD GUIDE, CPL.	COULISSE P. PROTÈGE-MAINS CPL.	CULISA P. PROTECCIÓN DE MANOS CPL.
5	165	1	1	1	1	1	1	1	1	1	1	1	1	1	1	1	181 213 371		SCHAUMSTOFFPLATTE		FOAM SPONGE	PLAQUE DE MOUSSE DE NYLON	CHAPA DE ESPUMA DE PLÁST.
5	167	1	1	1	1	1	1	1	1	1	1	1	1	1	1	1	181 213 161		HANDSCHUTZ KPL.		HAND GUARD CPL.	PROTÈGE-MAIN CPL.	PROTECTOR DE MANO CPL.
5	167															1	181 213 660		HANDSCHUTZ KPL.		HAND GUARD CPL.	PROTÈGE-MAIN CPL.	PROTECTOR DE MANO CPL.
5	168	1	1	1	1	1	1	1	1	1	1	1	1	1	1	1	980 114 237		SCHILD HANDSCHUTZ		LABEL	PLAQUE	CALCOMANIA
5	168															1	980 115 200		SCHILD HANDSCHUTZ	J	LABEL	PLAQUE	CALCOMANIA
5	169	1	1	1	1	1	1	1	1	1	1	1	1	1	1	1	181 213 310		DISTANZSTÜCK HANDSCHUTZ		SPACER	PIÈCE DISTANCE	SEPARADOR
5	170	1	1	1	1	1	1	1	1	1	1	1	1	1	1	1	181 213 320		BUCHSE FÜR HANDSCHUTZ		BUSHING	DOUILLE	CASQUILLO
5	171	1	1	1	1	1	1	1	1	1	1	1	1	1	1	1	908 805 205		ZYLINDERSCHRAUBE MIT SPANNSCHLEIBE	M5X20	SCREW	VIS	TORNILLO
5	173															1	181 250 030		ZACKENLEISTE	US	SPIKE BAR	BARRE DENTÉE	BARRA DENTADA

DCS460, DCS461, DCS500, DCS501,
DCS4600S, DCS4600SH, DCS5000,
DCS5000H, DCS5001, DCS5001H, DCS5121,
DCS460, DCS510, DCS5121, DE5045

5

Ölpumpe, Kupplung, Kettenbremse
Oil pump, clutch, chain brake
Pompe à huile, embrayage, frein de chaîne
Bomba de aceite, engrague, freno de cadena

Makita

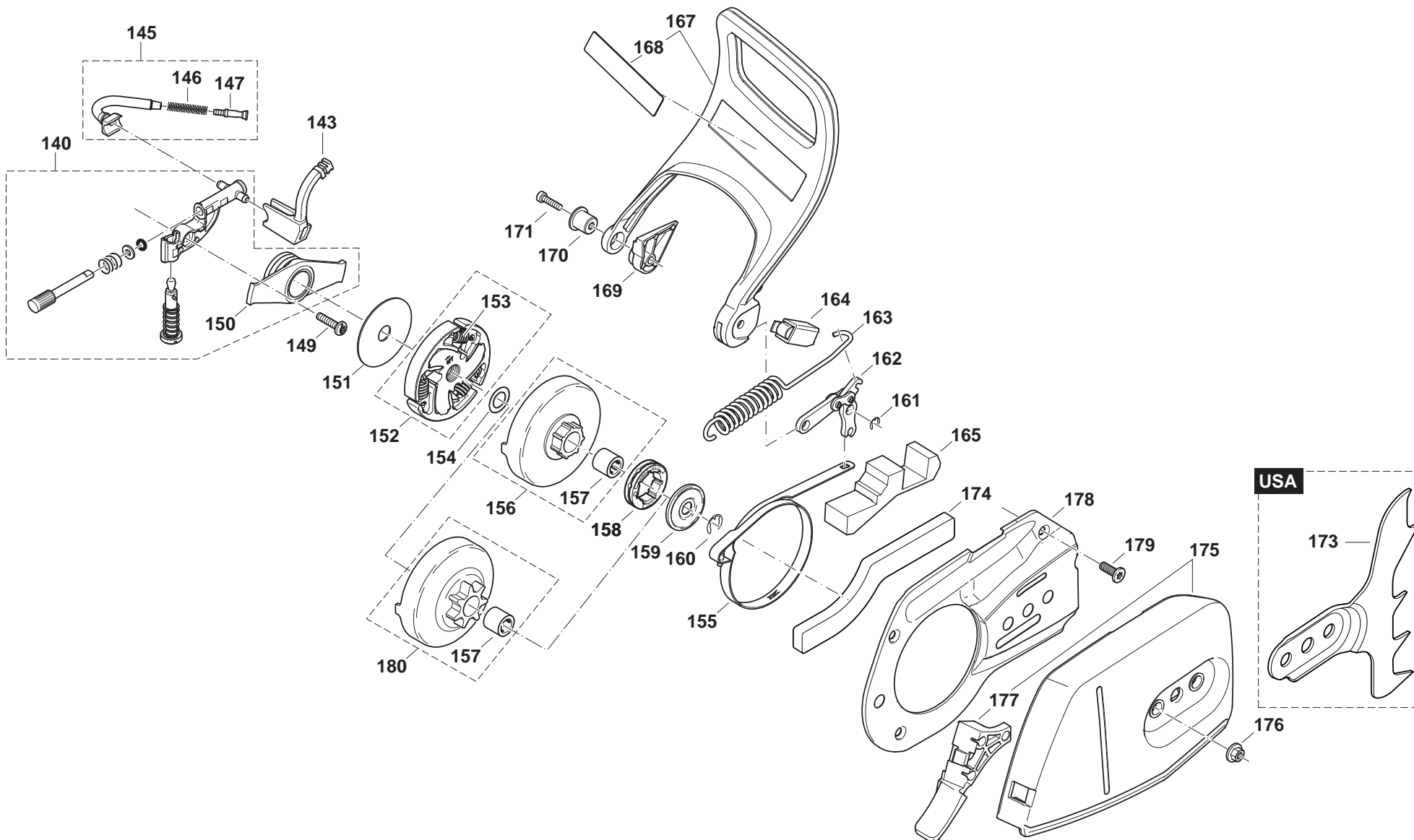

DCS460, DCS461, DCS500, DCS501,
DCS4600S, DCS4600SH, DCS5000,
DCS5000H, DCS5001, DCS5001H, DCS5121,
DCS460, DCS510, DCS5121, DE5045

5

Ölpumpe, Kupplung, Kettenbremse
Oil pump, clutch, chain brake
Pompe à huile, embrayage, frein de chaîne
Bomba de aceite, engrague, freno de cadena



Seite / Page	Pos.	DCS460	DCS461	DCS500	DCS501	DCS4600S	DCS4600SH	DCS5000	DCS5000H	DCS5001	DCS5001H	DCS5121	DCS460 (USA)	DCS510 (USA)	DCS5121 (USA)	DE5045	Teil-Nr. Part No. No. de pièce No. de pieza	Hinweise Notes Renseign. Nota	Bezeichnung	Spezifikation Specification	Description	Désignation	Denominación
5	174	1	1	1	1	1	1	1	1	1	1	1	1	1	1	1	181 213 400		SCHAUMSTOFFPLATTE		FOAM SPONGE	PLAQUE DE MOUSSE DE NYLON	CHAPA DE ESPUMA DE PLÁST.
5	175	1	1	1	1	1	1	1	1	1	1	1	1	1	1	1	957 213 600		KETTENRADSCHUTZ BLAU KPL.		SPROCKET GUARD CPL. BLUE	PROTÈGE-PIGNON CPL. BLEU	PROTECTOR DE PIÑON CPL. AZUL
5	176	2	2	2	2	2	2	2	2	2	2	2	2	2	2	2	923 208 004		6KT-MUTTER	M8	HEXAGONAL NUT	ECROU HEXAGONAL	TUERCA HEXAGONAL
5	177	1	1	1	1	1	1	1	1	1	1	1	1	1	1	1	957 213 220		SPANABWEISER		CHIP GUIDE	GUIDE DE COPEAUX	SALIDA DE VIRUTAS
5	178	1	1	1	1	1	1	1	1	1	1	1	1	1	1	1	181 213 191		ABDECKUNG KETTENBREMSE		COVER	COUVERCLE	CUBIERTA
5	179	3	3	3	3	3	3	3	3	3	3	3	3	3	3	3	908 105 126		SCHRAUBE	M5x12	SCREW	VIS	TORNILLO
5	180	1	1	1	1							1		1	1		181 223 311		KUPPLUNGSTROMMEL KPL.	.325", Z=7	CLUTCH DRUM CPL.	TAMBOUR CPL.	TAMBOR CPL.
5	180	1	1	1	1							1	1	1	1		181 223 321		KUPPLUNGSTROMMEL KPL.	3/8", Z=7	CLUTCH DRUM CPL.	TAMBOUR CPL.	TAMBOR CPL.

DCS460, DCS461, DCS500, DCS501,
 DCS4600S, DCS4600SH, DCS5000,
 DCS5000H, DCS5001, DCS5001H, DCS5121,
 DCS460, DCS510, DCS5121, DE5045

6

Vergaser
 Carburator
 Carburateur
 Carburador

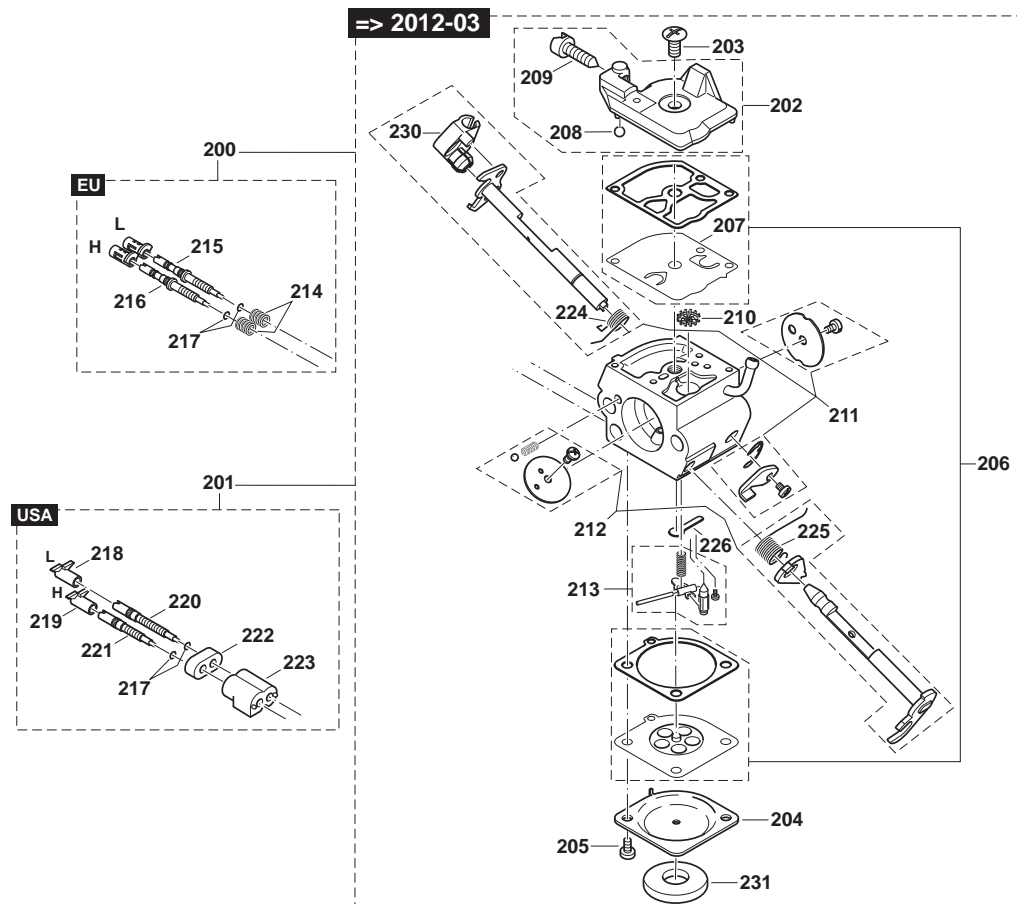
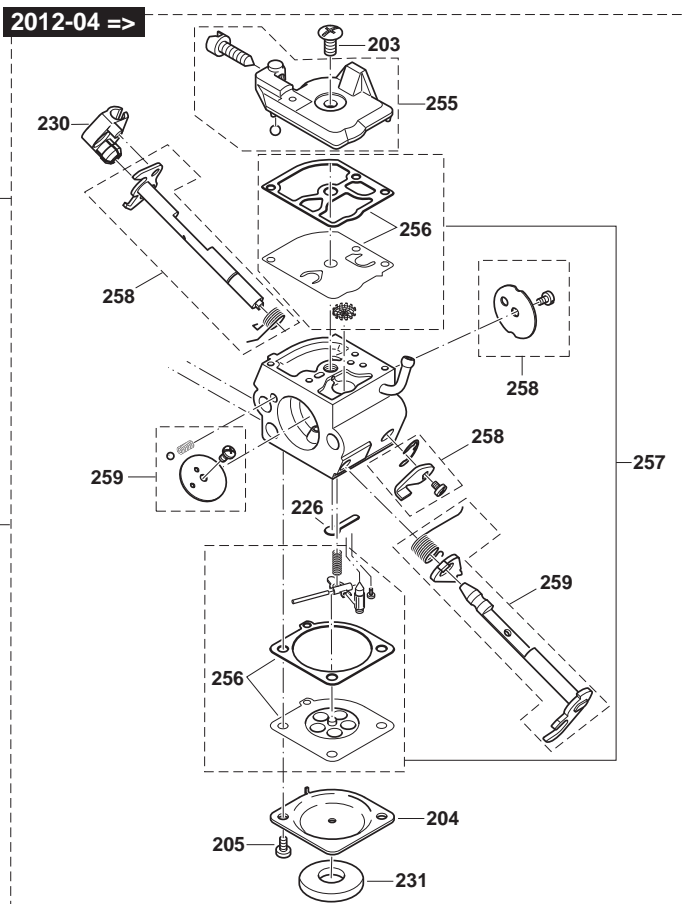

DCS460, DCS461, DCS500, DCS501,
DCS4600S, DCS4600SH, DCS5000,
DCS5000H, DCS5001, DCS5001H, DCS5121,
DCS460 , DCS510 , DCS5121 , DE5045

6

Vergaser
Carburetor
Carburateur
Carburador



Seite / Page	Pos.	DCS460	DCS461	DCS500	DCS501	DCS4600S	DCS4600SH	DCS5000	DCS5000H	DCS5001	DCS5001H	DCS5121	DCS460 (USA)	DCS510 (USA)	DCS5121 (USA)	DE5045	Teil-Nr. Part No. No. de pièce No. de pieza	Hinweise Notes Renseign. Nota	Bezeichnung	Spezifikation Specification	Description	Désignation	Denominación
6	200	1	1	1	1	1	1	1	1	1	1	1				1	181 153 100 => 2012-03		VERGASER KPL.	LC - EU / J	CARBURETOR	CARBURATEUR	CARBURADOR
6	201												1	1	1		181 153 300 => 2012-03		VERGASER KPL.	LC - US	CARBURETOR	CARBURATEUR	CARBURADOR
6	202	1	1	1	1	1	1	1	1	1	1	1	1	1	1	1	181 153 030 => 2012-03		PUMPENDECKEL KPL.		PUMP COVER CPL.	COUVERCLE DE POMPE CPL.	TAPA DE BOMBA CPL.
6	203	1	1	1	1	1	1	1	1	1	1	1	1	1	1	1	038 153 360		SCHRAUBE FÜR PUMPENDECKEL		SCREW	VIS	TORNILLO
6	204	1	1	1	1	1	1	1	1	1	1	1	1	1	1	1	181 153 040		MEMBRANDECKEL		DIAPHRAGM COVER	COUVERCLE DE MEMBRANE	TAPA DE MEMBRANA
6	205	2	2	2	2	2	2	2	2	2	2	2	2	2	2	2	001 153 020 => 2012-03		SCHRAUBE FÜR REGELDECKEL		SCREW	VIS	TORNILLO
6	206	1	1	1	1	1	1	1	1	1	1	1	1	1	1	1	181 153 020 => 2012-03		DICHTUNG UND MEMBRANSATZ		SET DIAPHRAGM / GASKETS	JEU DE MEMBRANES / JOINTS	JUEGO MEMBRANAS / JUNTAS
6	207	1	1	1	1	1	1	1	1	1	1	1	1	1	1	1	181 153 050		PUMPENMEMBRAN, TEFLON		PUMP DIAPHRAGM TEFLON	MEMBRANE DE POMPE TEFLON	MEMBRANA DE LA BOMBA TEFLON
6	207	1	1	1	1	1	1	1	1	1	1	1	1	1	1	1	181 153 060		PUMPENMEMBRAN, GUMMI		PUMP DIAPHRAGM RUBBER	MEMBRANE DE POMPE CAOUTCH.	MEMBRANA DE LA BOMBA CAUCHO
6	208	1	1	1	1	1	1	1	1	1	1	1	1	1	1	1	038 153 210		ARRETIERKUGEL		FRICTION BALL	BILLE DE ARRÊT	BOLA
6	209	1	1	1	1	1	1	1	1	1	1	1	1	1	1	1	181 153 070 => 2012-03		LEERLAUF-ANSCHLAG SCHRAUBE	S	IDLE STOP SCREW	VIS DE BUTÉE DE RALENTI	TORNILLO DE TOPE
6	210	1	1	1	1	1	1	1	1	1	1	1	1	1	1	1	036 153 040		SIEB		SCREEN	TAMIS	TAMIZ
6	211	1	1	1	1	1	1	1	1	1	1	1	1	1	1	1	957 153 090 => 2012-03		REP.-SATZ DROSSELWELLE		KIT THROTTLE SHAFT	JEU AXE CLAPET D'ÉTRANG.	JUEGO EJE VÁLVULA REG.
6	212	1	1	1	1	1	1	1	1	1	1	1	1	1	1	1	957 153 080 => 2012-03		REP.-SATZ CHOKEWELLE		KIT CHOKE SHAFT	JEU AXE CLAPET D'AIR	JUEGO EJE VÁLVULA AIRE
6	213	1	1	1	1	1	1	1	1	1	1	1	1	1	1	1	957 153 070 => 2012-03		STEUERTEILE		CONTROL PARTS	PIÈCES DE COMMANDE	PIEZAS DE MANDO
6	214	2	2	2	2	2	2	2	2	2	2	2				2	028 153 480 => 2012-03		FEDER		SPRING	RESSORT	RESORTE
6	215	1	1	1	1	1	1	1	1	1	1	1				1	181 153 180 => 2012-03		LEERLAUF-STELLSCHRAUBE	L - EU	IDLE ADJUSTMENT SCREW	VIS DE RÉGL. DE RALENTI	TORNILLO REGULADOR
6	216	1	1	1	1	1	1	1	1	1	1	1				1	181 153 190 => 2012-03		VOLLGAS-STELLSCHR AUBE	H - EU	MAIN ADJUSTMENT SCREW	VIS DE RÉGL. PLEIN GAZ	TORNILLO REGULADOR
6	217	2	2	2	2	2	2	2	2	2	2	2	2	2	2	2	181 153 220 => 2012-03		SCHEIBE		WASHER	RONDELLE	ARANDELA
6	218												1	1	1		181 153 280 => 2012-03		LIMITER CAP, WEISS	US	LIMITER CAP, WHITE	CAPUCHON LIMITEUR, BLANC	CAPUCHONE LIMITADORE, BLANCO
6	219												1	1	1		038 153 310 => 2012-03		LIMITER CAP, ROT	US	LIMITER CAP, RED	CAPUCHON LIMITEUR, ROUGE	CAPUCHONE LIMITADORE, ROJO
6	220												1	1	1		181 153 260 => 2012-03		LEERLAUF-STELLSCHRAUBE	L - US	IDLE ADJUSTMENT SCREW	VIS DE RÉGL. DE RALENTI	TORNILLO REGULADOR
6	221												1	1	1		181 153 270 => 2012-03		VOLLGAS-STELLSCHR AUBE	H - US	MAIN ADJUSTMENT SCREW	VIS DE RÉGL. PLEIN GAZ	TORNILLO REGULADOR
6	222												1	1	1		181 153 290 => 2012-03		GUMMIRING	US	RUBBER RING	RONDELLE DE CAOUTCHOUC	ARANDELA DE GOMA

DCS460, DCS461, DCS500, DCS501,
 DCS4600S, DCS4600SH, DCS5000,
 DCS5000H, DCS5001, DCS5001H, DCS5121,
 DCS460, DCS510, DCS5121, DE5045

6

Vergaser
 Carburator
 Carburateur
 Carburador

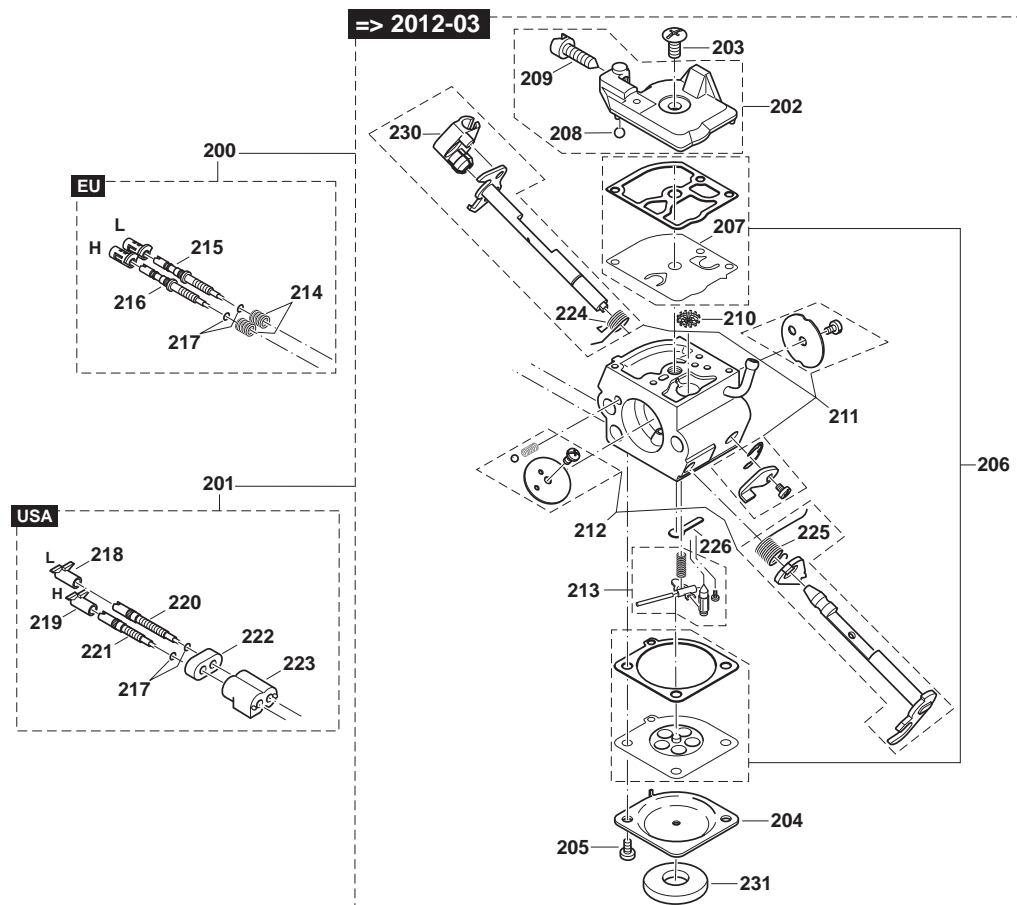
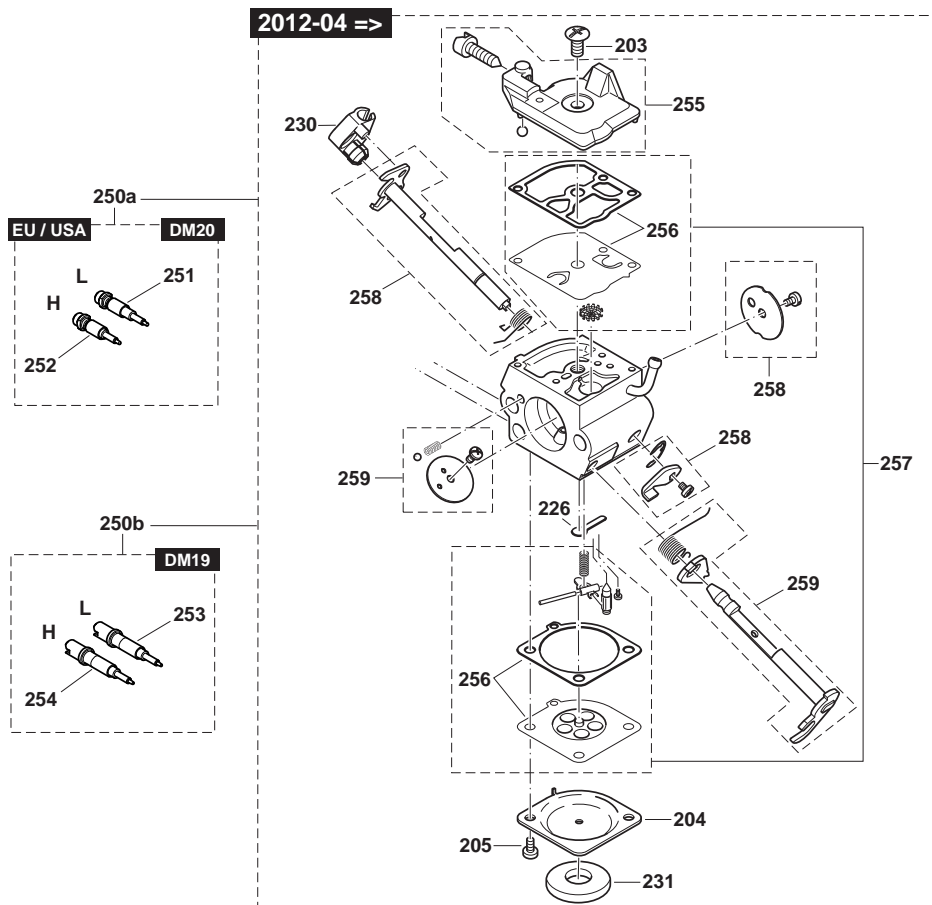

DCS460, DCS461, DCS500, DCS501,
DCS4600S, DCS4600SH, DCS5000,
DCS5000H, DCS5001, DCS5001H, DCS5121,
DCS460, DCS510, DCS5121, DE5045

6

Vergaser
Carburetor
Carburateur
Carburador



Seite / Page	Pos.	DCS460	DCS461	DCS500	DCS501	DCS4600S	DCS4600SH	DCS5000	DCS5000H	DCS5001	DCS5001H	DCS5121	DCS460 (USA)	DCS510 (USA)	DCS5121 (USA)	DE5045	Teil-Nr. Part No. No. de pièce No. de pieza	Hinweise Notes Renseign. Nota	Bezeichnung	Spezifikation Specification	Description	Désignation	Denominación
6	223												1	1	1		038 153 320	=> 2012-03	EINSTELLFÜHRUNG	US	ADJUSTING GUIDE	GUIDAGE D'AJUSTAGE	GUÍA DE AJUSTE
6	224	1	1	1	1	1	1	1	1	1	1	1	1	1	1	1	181 153 110		DREHFEDER FÜR DROSSELKLAPPE		SPRING	RESSORT	RESORTE
6	225	1	1	1	1	1	1	1	1	1	1	1	1	1	1	1	181 153 160		DREHFEDER		SPRING	RESSORT	RESORTE
6	226	1	1	1	1	1	1	1	1	1	1	1	1	1	1	1	181 153 210	=> 2012-03	VERSCHLUßSCHEIBE		PLUG-WELCH	RONDELLE DE FERMETURE	DISCO DE CIERRE
6	230	1	1	1	1	1	1	1	1	1	1	1	1	1	1	1	038 155 012		AUFNAHME FÜR BOWDENZUG		RETAINING CLIP	SUPPORT DU DISPOS. DE TIRAGE	TRACCIÓN BOWDEN, SOPORTE
6	231	1	1	1	1	1	1	1	1	1	1	1	1	1	1	1	965 402 995		DICHTUNG SELBSTKLEBEND		GASKET	JOINT	JUNTA
6	250a	1	1	1	1	1	1	1	1	1	1	1	1	1	1	1	181 153 301	2012-04 =>	VERGASER KPL.	DM20, DD - EU, USA (regulated market)	CARBURETOR	CARBURATEUR	CARBURADOR
6	250b	1	1	1	1	1	1	1	1	1	1	1				1	181 153 101	2012-04 =>	VERGASER KPL.	DM19 (non regulated market)	CARBURETOR	CARBURATEUR	CARBURADOR
6	251	1	1	1	1	1	1	1	1	1	1	1	1	1	1	1	181 153 261	2012-04 =>	STELLSCHRAUBE	L DD - EU, US (regulated market)	IDLE ADJUSTMENT SCREW	VIS DE RÉGL. DE RALENTI	TORNILLO REGULADOR
6	252	1	1	1	1	1	1	1	1	1	1	1	1	1	1	1	181 153 271	2012-04 =>	STELLSCHRAUBE	H DD - EU, US (regulated market)	MAIN ADJUSTMENT SCREW	VIS DE RÉGL. PLEIN GAZ	TORNILLO REGULADOR
6	253	1	1	1	1	1	1	1	1	1	1					1	181 153 181	2012-04 =>	STELLSCHRAUBE	L (non regulated market)	IDLE ADJUSTMENT SCREW	VIS DE RÉGL. DE RALENTI	TORNILLO REGULADOR
6	254	1	1	1	1	1	1	1	1	1	1					1	181 153 191	2012-04 =>	STELLSCHRAUBE	H (non regulated market)	MAIN ADJUSTMENT SCREW	VIS DE RÉGL. PLEIN GAZ	TORNILLO REGULADOR
6	255	1	1	1	1	1	1	1	1	1	1	1	1	1	1	1	181 153 031	2012-04 =>	PUMPENDECKEL KPL.		PUMP COVER CPL.	COUVERCLE DE POMPE CPL.	TAPA DE BOMBA CPL.
6	256	1	1	1	1	1	1	1	1	1	1	1	1	1	1	1	181 153 021	2012-04 =>	DICHTUNG UND MEMBRAN, SATZ (INCL. PUMPENMEMBRAN GUMMI+MYLAR)		SET DIAPHRAGM / GASKETS (INCL. PUMP DIAPHRAGM RUBBER+MYLAR)	JEU DE MEMBRANES / JOINTS (INCL. MEMBRANE DE POMPE CAOUTCH.+MYLAR)	JUEGO MEMBRANAS / JUNTAS (INCL. MEMBRANA DE LA BOMBA CAUCHO+MYLAR)
6	257	1	1	1	1	1	1	1	1	1	1	1	1	1	1	1	181 153 560	2012-04 =>	REPARATURSATZ VERGASER		REBUILD KIT	JEU DE RÉPARATION	JUEGO DE REPARAR
6	258	1	1	1	1	1	1	1	1	1	1	1	1	1	1	1	181 153 570	2012-04 =>	REP.-SATZ DROSSELWELLE		KIT THROTTLE SHAFT	JEU AXE CLAPET D'ÉTRANG.	JUEGO EJE VÁLVULA REG.
6	259	1	1	1	1	1	1	1	1	1	1	1	1	1	1	1	181 153 580	2012-04 =>	REP.-SATZ CHOKEWELLE		KIT CHOKE SHAFT	JEU AXE CLAPET D'AIR	JUEGO EJE VÁLVULA AIRE

DCS460, DCS461, DCS500, DCS501,
DCS4600S, DCS4600SH, DCS5000,
DCS5000H, DCS5001, DCS5001H, DCS5121,
DCS460, DCS510, DCS5121, DE5045

7

Spezialteile für Ausrüstung mit elektrischer Griffheizung
Special parts for version with electric handle heating
Pièces spéciales pour version avec chauffage de la poignée (électrique)
Piezas especiales por tipo con calefacción eléctrica de mango

Makita[®]

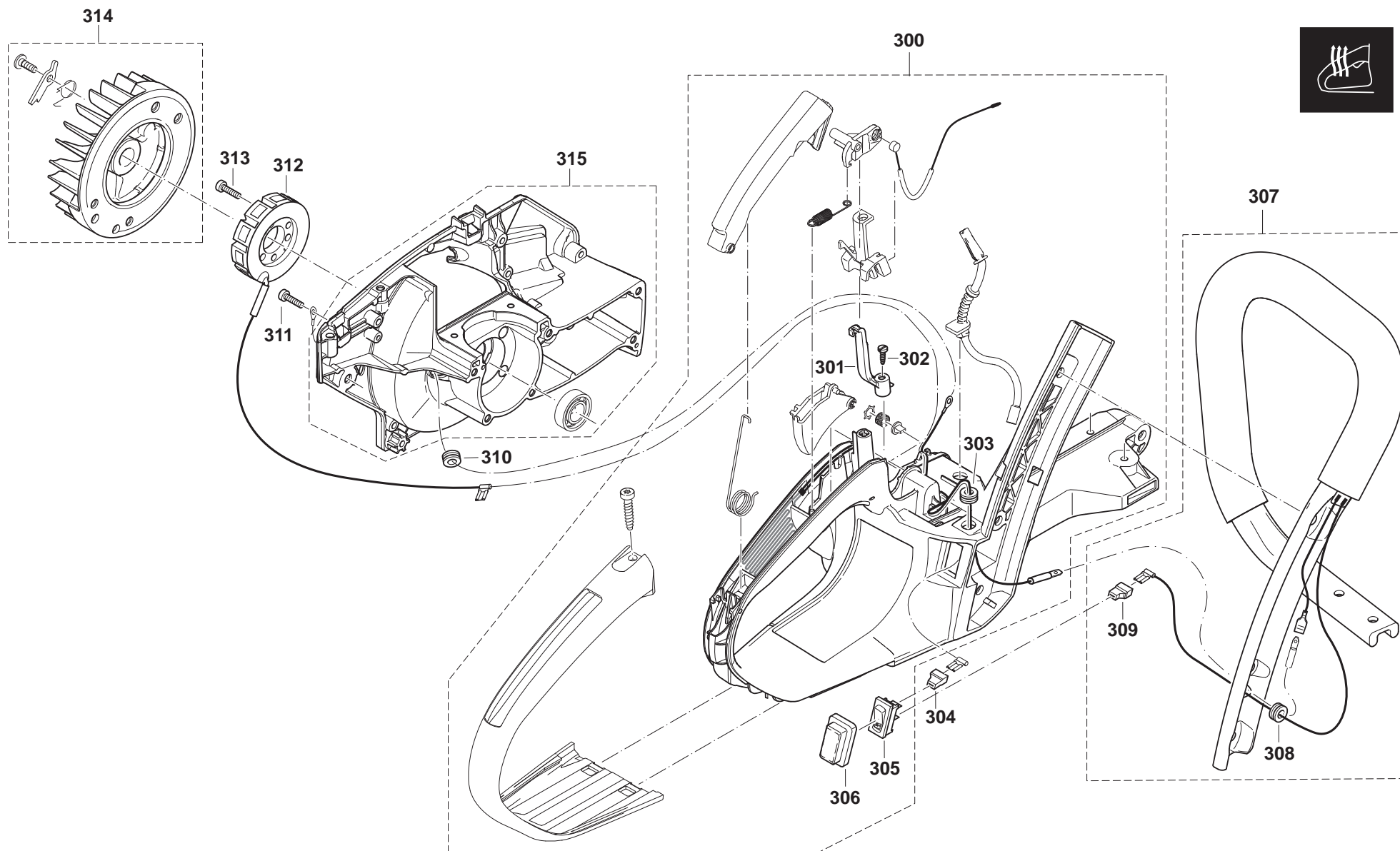

DCS460, DCS461, DCS500, DCS501,
DCS4600S, DCS4600SH, DCS5000,
DCS5000H, DCS5001, DCS5001H, DCS5121,
DCS460, DCS510, DCS5121, DE5045

7

Spezialteile für Ausrüstung mit elektrischer Griffheizung
Special parts for version with electric handle heating
Pièces spéciales pour version avec chauffage de la poignée (électrique)
Piezas especiales por tipo con calefacción eléctrica de mango



Seite / Page	Pos.	DCS4600SH	DCS5000H	DCS5001H	Teil-Nr. Part No. No. de pièce No. de pieza	Hinweise Notes Renseign. Nota	Bezeichnung	Spezifikation Specification	Description	Désignation	Denominación
7	300	1	1	1	181 114 670		KRAFTSTOFFTANK BLAU KPL. HEIZ.		TANK CPL. BLUE HANDLE HEAT.	RÉSERVOIR CPL. BLEU CHAUFF.	DEPÓSITO CPL. AZUL CALEFAC.
7	300	1	1	1	181 114 730		KRAFTSTOFFTANK BLAU KPL. HEIZ.	USA (EPA), INCL.181b	TANK CPL. BLUE HANDLE HEAT.	RÉSERVOIR CPL. BLEU CHAUFF.	DEPÓSITO CPL. AZUL CALEFAC.
7	301	1	1	1	181 148 071		KABELFÜHRUNG		CABLE GUIDE	PASSE-CÂBLES	PASAMUROS PARA CABLE
7	302	1	1	1	915 535 100		SCHRAUBE	3,5x9,5	SCREW	VIS	TORNILLO
7	303	1	1	1	965 401 011		GUMMITÜLLE		RUBBER BUSHING	GAINÉ CAOUTCHOUC	BOQUILLA DE CAUCHO
7	304	1	1	1	038 146 030		ISOLIERKAPPE GELB		INSULATING CAP	CHAPE D'ISOLATION	CUBIERTO DE AISLADOR
7	305	1	1	1	975 001 230		GERÄTESCHALTER EIN/AUS		SWITCH	INTERRUPTEUR	INTERRUPTOR
7	306	1	1	1	975 001 260		KAPPE FÜR GERÄTESCHALTER		SWITCH END CAP	CAPUCHON	CAPERUZA
7	307	1	1	1	181 310 150		BÜGELGRIFF KPL. HEIZUNG		TUBULAR HANDLE ASSY.	POIGNÉE TUBULAIRE CPL.	MANGO TUBULAR CPL.
7	308	1	1	1	965 401 011		GUMMITÜLLE		RUBBER BUSHING	GAINÉ CAOUTCHOUC	BOQUILLA DE CAUCHO
7	309	1	1	1	038 146 030		ISOLIERKAPPE GELB		INSULATING CAP	CHAPE D'ISOLATION	CUBIERTO DE AISLADOR
7	310	1	1	1	965 401 011		GUMMITÜLLE		RUBBER BUSHING	GAINÉ CAOUTCHOUC	BOQUILLA DE CAUCHO
7	311	1	1	1	908 004 125		INNENSTERN-SCHRAUBE	4x12	SCREW	VIS	TORNILLO
7	312	1	1	1	181 148 060		GENERATORANKER HEIZUNG		GENERATOR COIL	BOBINE GÉNÉRATRICE	BOBINA GENERADOR
7	313	3	3	3	908 004 125		INNENSTERN-SCHRAUBE	4x12	SCREW	VIS	TORNILLO
7	314	1	1	1	181 148 105		POLRAD KPL. GRIFFHEIZUNG		FLYWHEEL ASSY.	ROUE POLAIRE CPL.	VOLANTE ENCENDIDO
7	315	1	1	1	181 111 663		KURBELGEHÄUSE MS BLAU HEIZ.		CRANKC. MA. SIDE BLUE	CARTER-COTÉ MAGN.	CÁRTER CIG. LADO MAG.

DCS460, DCS461, DCS500, DCS501,
DCS4600S, DCS4600SH, DCS5000,
DCS5000H, DCS5001, DCS5001H, DCS5121,
DCS460, DCS510, DCS5121, DE5045

8

Sägeschienen, Sägeketten, Werkzeug
Guide bars, saw chains, tools
Guide-chaîne, chaînes, outils
Rieles guía, cadenas sierra, herramientas



.325"

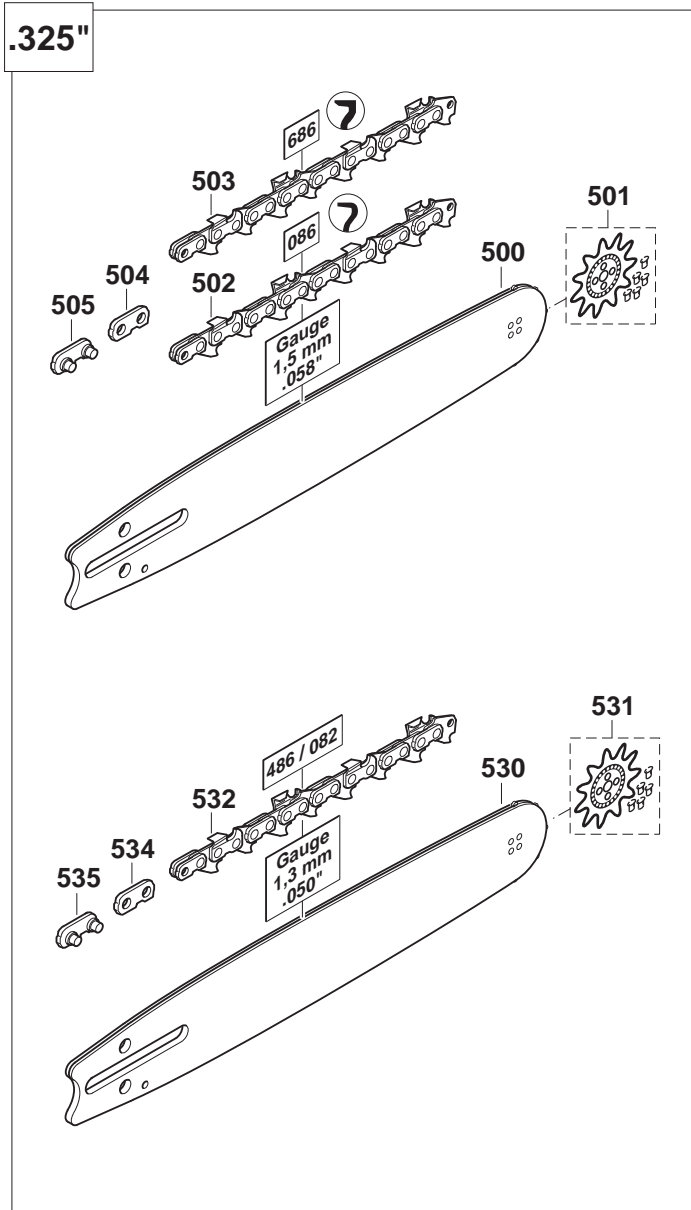

3/8"

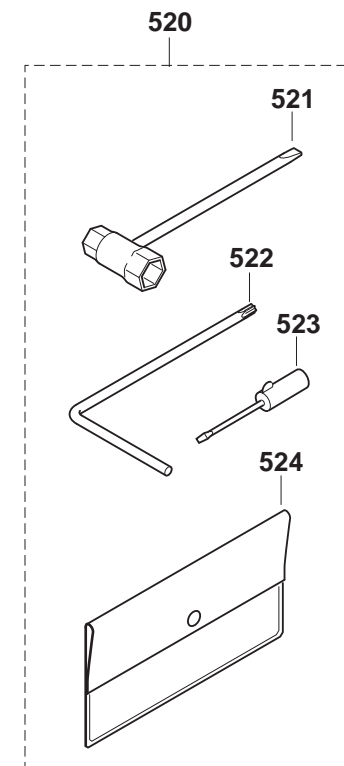
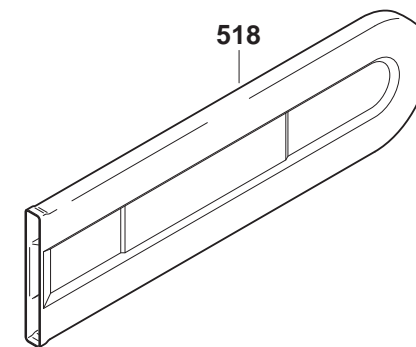
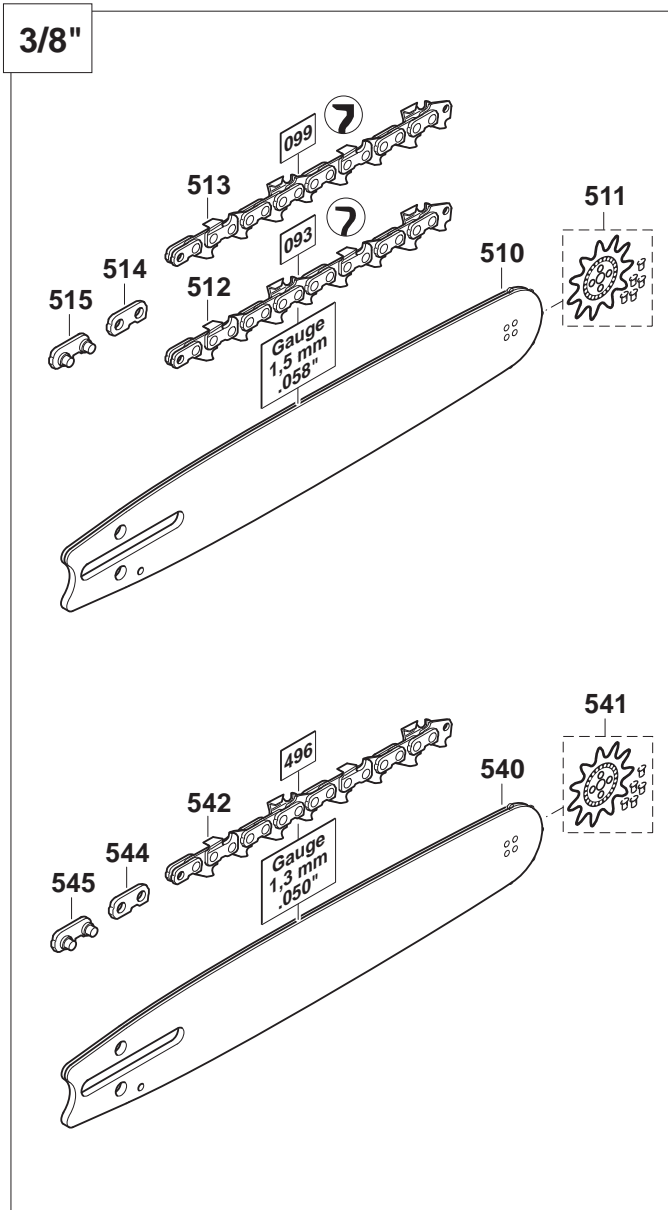

DCS460, DCS461, DCS500, DCS501,
DCS4600S, DCS4600SH, DCS5000,
DCS5000H, DCS5001, DCS5001H, DCS5121,
DCS460, DCS510, DCS5121, DE5045

8

Sägeschienen, Sägeketten, Werkzeug
Guide bars, saw chains, tools
Guide-chaîne, chaînes, outils
Rieles guía, cadenas sierra, herramientas



Seite / Page	Pos.	DCS460	DCS461	DCS500	DCS501	DCS4600S	DCS4600SH	DCS5000	DCS5000H	DCS5001	DCS5001H	DCS5121	DCS460 (USA)	DCS510 (USA)	DCS5121 (USA)	DE5045	Teil-Nr. Part No. No. de pièce No. de pieza	Hinweise Notes Renseign. Nota	Bezeichnung	Spezifikation Specification	Description	Désignation	Denominación
8	500	1	1	1	1	1	1	1	1	1	1	1	1	1	1	1	445 033 631		STERNSCHIENE	.325" .058" 33CM-13"	SPROCKET NOSE BAR	GUIDE À ÉTOILE	GUÍA CON ESTRELLA
8	500	1	1	1	1	1	1	1	1	1	1	1	1	1	1	1	445 038 631		STERNSCHIENE	.325" .058" 38CM-15"	SPROCKET NOSE BAR	GUIDE À ÉTOILE	GUÍA CON ESTRELLA
8	500	1	1	1	1	1	1	1	1	1	1	1	1	1	1	1	445 045 631		STERNSCHIENE	.325" .058" 45CM-18"	SPROCKET NOSE BAR	GUIDE À ÉTOILE	GUÍA CON ESTRELLA
8	501	1	1	1	1	1	1	1	1	1	1	1	1	1	1	1	415 325 710		UMLENKSTERN KPL.	.325" .058"	SPROCKET NOSE	ÉTOILE	ESTRELLA
8	502	1	1	1	1	1	1	1	1	1	1	1	1	1	1	1	528 086 656		SÄGEKETTE	.325" .058" 33CM-13"	SAW CHAIN	CHAÎNE	CADENA
8	502	1	1	1	1	1	1	1	1	1	1	1	1	1	1	1	528 086 664		SÄGEKETTE	.325" .058" 38CM-15"	SAW CHAIN	CHAÎNE	CADENA
8	502	1	1	1	1	1	1	1	1	1	1	1	1	1	1	1	528 086 672		SÄGEKETTE	.325" .058" 45CM-18"	SAW CHAIN	CHAÎNE	CADENA
8	503	1	1	1	1	1	1	1	1	1	1	1	1	1	1	1	534 686 056		SÄGEKETTE	.325" .058" 33CM-13"	SAW CHAIN	CHAÎNE	CADENA
8	503	1	1	1	1	1	1	1	1	1	1	1	1	1	1	1	534 686 064		SÄGEKETTE	.325" .058" 38CM-15"	SAW CHAIN	CHAÎNE	CADENA
8	503	1	1	1	1	1	1	1	1	1	1	1	1	1	1	1	534 686 072		SÄGEKETTE	.325" .058" 45CM-18"	SAW CHAIN	CHAÎNE	CADENA
8	504	1	1	1	1	1	1	1	1	1	1	1	1	1	1	1	558 083 000		AUßENLASCHE	.325" .058"	TIE STRAP	ECLISSE EXTERIEURE	TIRA EXTER.
8	505	1	1	1	1	1	1	1	1	1	1	1	1	1	1	1	558 083 010		AUßENLASCHE MIT NIET	.325" .058"	TIE STRAP WITH RIVETS	ECLISSE EXTERIEURE A. RIVETS	TIRA EXTER. CON REMACHE
8	510	1	1	1	1	1	1	1	1	1	1	1	1	1	1	1	443 038 651		STERNSCHIENE	3/8" .058" 38CM-15"	SPROCKET NOSE BAR	GUIDE À ÉTOILE	GUÍA CON ESTRELLA
8	510	1	1	1	1	1	1	1	1	1	1	1	1	1	1	1	443 045 651		STERNSCHIENE	3/8" .058" 45CM-18"	SPROCKET NOSE BAR	GUIDE À ÉTOILE	GUÍA CON ESTRELLA
8	510	1	1	1	1	1	1	1	1	1	1	1	1	1	1	1	443 053 651		STERNSCHIENE	3/8" .058" 53CM-21"	SPROCKET NOSE BAR	GUIDE À ÉTOILE	GUÍA CON ESTRELLA
8	511	1	1	1	1	1	1	1	1	1	1	1	1	1	1	1	415 038 720		UMLENKSTERN	3/8" .058"	SPROCKET NOSE	ÉTOILE	ESTRELLA
8	512	1	1	1	1	1	1	1	1	1	1	1	1	1	1	1	523 093 656		SÄGEKETTE	3/8" .058" 38CM-15"	SAW CHAIN	CHAÎNE	CADENA
8	512	1	1	1	1	1	1	1	1	1	1	1	1	1	1	1	523 093 664		SÄGEKETTE	3/8" .058" 45CM-18"	SAW CHAIN	CHAÎNE	CADENA
8	512	1	1	1	1	1	1	1	1	1	1	1	1	1	1	1	523 093 672		SÄGEKETTE	3/8" .058" 53CM-21"	SAW CHAIN	CHAÎNE	CADENA
8	513	1	1	1	1	1	1	1	1	1	1	1	1	1	1	1	528 099 656		SÄGEKETTE	3/8" .058" 35/38CM-14/15"	SAW CHAIN	CHAÎNE	CADENA
8	513	1	1	1	1	1	1	1	1	1	1	1	1	1	1	1	528 099 672		SÄGEKETTE	3/8" .058" 53CM-21"	SAW CHAIN	CHAÎNE	CADENA
8	513	1	1	1	1	1	1	1	1	1	1	1	1	1	1	1	528 099 664		SÄGEKETTE	3/8" .058" 45CM-18"	SAW CHAIN	CHAÎNE	CADENA
8	514	1	1	1	1	1	1	1	1	1	1	1	1	1	1	1	558 093 000		AUßENLASCHE	3/8" .058"	TIE STRAP	ECLISSE EXTERIEURE	TIRA EXT.
8	515	1	1	1	1	1	1	1	1	1	1	1	1	1	1	1	558 093 010		AUßENLASCHE MIT NIET	3/8" .058"	TIE STRAP WITH RIVETS	ECLISSE AVEC RIVETS	TIRA EXT. CON REMACHES
8	518	1	1	1	1	1	1	1	1	1	1	1	1	1	1	1	952 010 630		KETTENSCHUTZ	30-35 cm	CHAIN PROTECTION	PROTECTION CHAÎNE	PROTECTOR DE CADENA
8	518	1	1	1	1	1	1	1	1	1	1	1	1	1	1	1	952 020 640		KETTENSCHUTZ	38-45 cm	CHAIN PROTECTION	PROTECTION CHAÎNE	PROTECTOR DE CADENA
8	518	1	1	1	1	1	1	1	1	1	1	1	1	1	1	1	952 020 650		KETTENSCHUTZ	50 cm	CHAIN PROTECTION	PROTECTION CHAÎNE	PROTECTOR DE CADENA
8	520	1	1	1	1	1	1	1	1	1	1	1	1	1	1	1	957 004 002		WERKZEUG KPL.		TOOL CPL.	OUTILS CPL.	HERRAMIENTAS CPL.
8	521	1	1	1	1	1	1	1	1	1	1	1	1	1	1	1	941 719 131		KOMBISCHLÜSSEL	SW 13/19 mm	UNIVERSAL WRENCH	CLÉ COMBINÉE	LLAVE DE BUJIA

DCS460, DCS461, DCS500, DCS501,
DCS4600S, DCS4600SH, DCS5000,
DCS5000H, DCS5001, DCS5001H, DCS5121,
DCS460, DCS510, DCS5121, DE5045

8

Sägeschienen, Sägeketten, Werkzeug
Guide bars, saw chains, tools
Guide-chaîne, chaînes, outils
Rieles guía, cadenas sierra, herramientas



.325"

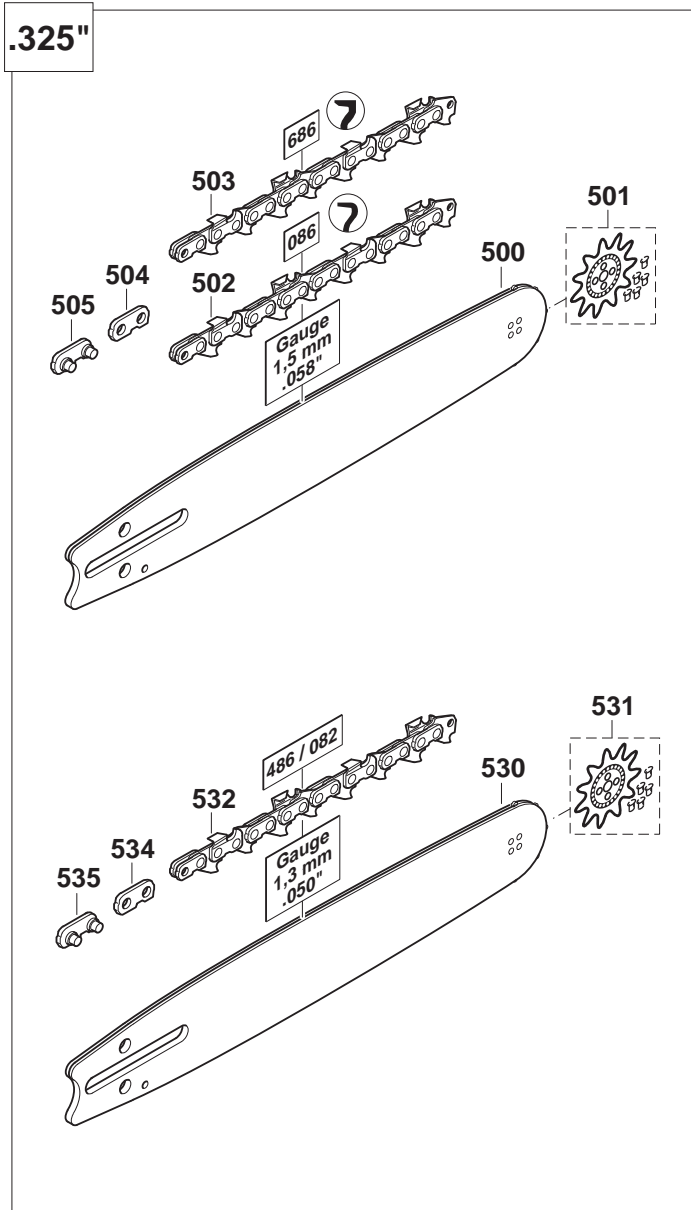

3/8"

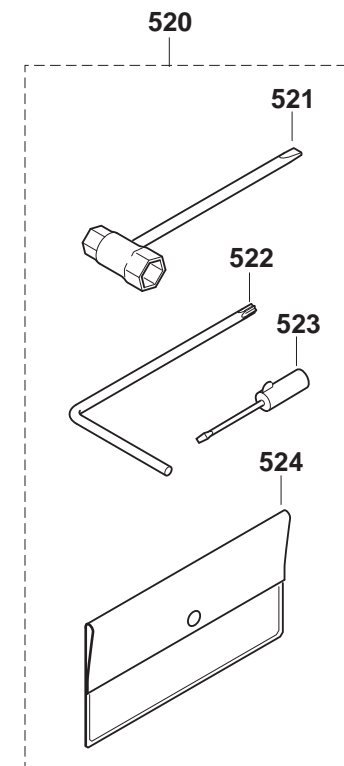
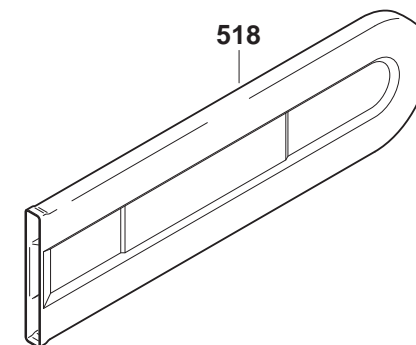
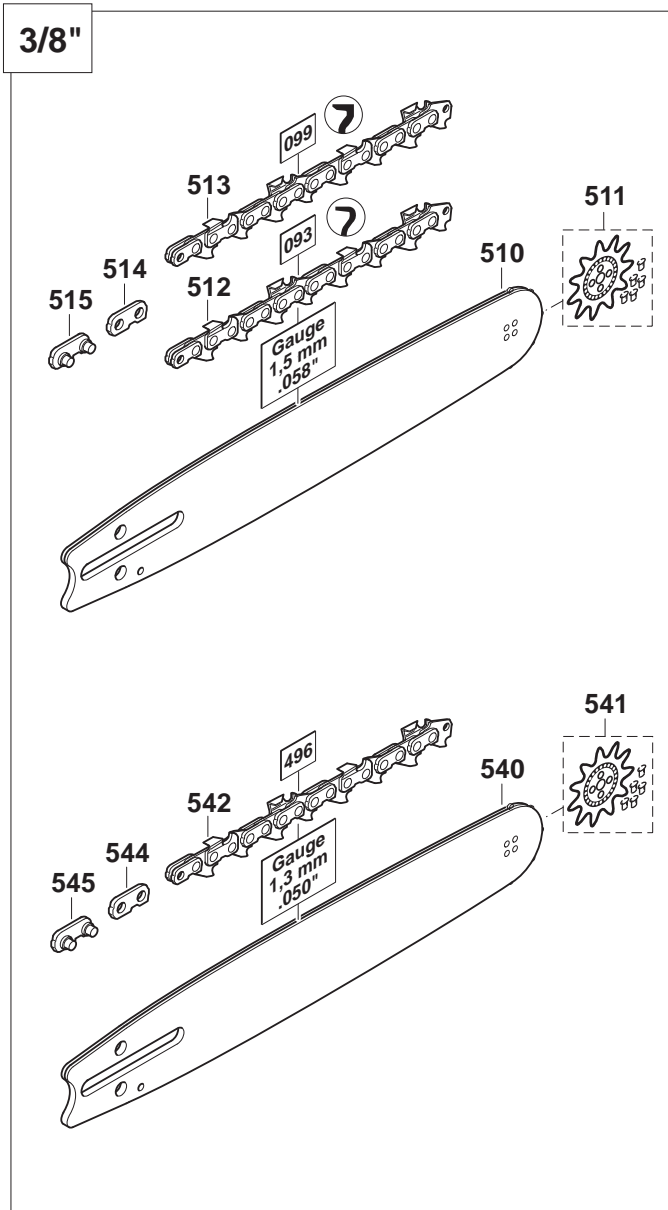

DCS460, DCS461, DCS500, DCS501,
DCS4600S, DCS4600SH, DCS5000,
DCS5000H, DCS5001, DCS5001H, DCS5121,
DCS460, DCS510, DCS5121, DE5045

8

Sägeschienen, Sägeketten, Werkzeug
Guide bars, saw chains, tools
Guide-chaîne, chaînes, outils
Rieles guía, cadenas sierra, herramientas



Seite / Page	Pos.	DCS460	DCS461	DCS500	DCS501	DCS4600S	DCS4600SH	DCS5000	DCS5000H	DCS5001	DCS5001H	DCS5121	DCS460 (USA)	DCS510 (USA)	DCS5121 (USA)	DE5045	Teil-Nr. Part No. No. de pièce No. de pieza	Hinweise Notes Renseign. Nota	Bezeichnung	Spezifikation Specification	Description	Désignation	Denominación
8	522	1	1	1	1	1	1	1	1	1	1	1	1	1	1	1	940 827 000		WINKELSCHRAUBENDR EHER	T27	ANGLED SCREW DRIVER	CLÉ ANGLE	LLAVE ANGULAR
8	523	1	1	1	1	1	1	1	1	1	1	1	1	1	1	1	944 340 001		SCHRAUBENDREHER		SCREWDRIVER	TOURNEVIS	DESTORNILLADOR
8	524	1	1	1	1	1	1	1	1	1	1	1	1	1	1	1	950 004 002		WERKZEUGTASCHE		PLASTIK BAG	POCHETTE EN PLASTIQUE	CÁRTERA HERRAMIENTAS
8	530													1	1		445 040 641	US	STERNSCHIENE	.325" .050" 40CM-16"	SPROCKET NOSE BAR	GUIDE À ÉTOILE	GUÍA CON ESTRELLA
8	531													1	1		415 325 720	US	UMLENKSTERN KPL.	.325" .050"	SPROCKET NOSE	ÉTOILE	ESTRELLA
8	532													1	1		523 082 666	US	SÄGEKETTE	.325" .050" 40CM-16"	SAW CHAIN	CHAÎNE	CADENA
8	532													1	1		513 486 672	US	SÄGEKETTE	.325" .050" 45CM-18"	SAW CHAIN	CHAÎNE	CADENA
8	534													1	1		558 486 000	US	AUßENLASCHE	.325" .050"	TIE STRAP	ECLISSE EXTERIEURE	TIRA EXT.
8	535													1	1		558 486 010	US	AUßENLASCHE MIT NIET	.325" .050"	TIE STRAP WITH RIVETS	ECLISSE AVEC RIVETS	TIRA EXT. CON REMACHES
8	540													1	1	1	443 045 661	US	STERNSCHIENE	3/8" .050" 45CM-18"	SPROCKET NOSE BAR	GUIDE À ÉTOILE	GUÍA CON ESTRELLA
8	541													1	1	1	415 038 730	US	UMLENKSTERN KPL.	3/8" .050"	SPROCKET NOSE	ÉTOILE	ESTRELLA
8	542													1	1	1	513 496 664	US	SÄGEKETTE	3/8" .050" 45CM-18"	SAW CHAIN	CHAÎNE	CADENA
8	544													1	1	1	558 496 000	US	AUßENLASCHE	3/8" .050"	TIE STRAP	ECLISSE EXTERIEURE	TIRA EXT.
8	545													1	1	1	558 496 010	US	AUßENLASCHE MIT NIET	3/8" .050"	TIE STRAP WITH RIVETS	ECLISSE AVEC RIVETS	TIRA EXT. CON REMACHES

DCS460, DCS461, DCS500, DCS501,
 DCS4600S, DCS4600SH, DCS5000,
 DCS5000H, DCS5001, DCS5001H, DCS5121,
 DCS460 , DCS510 , DCS5121 , DE5045



	Zeichenerklärung	Key to symbols	Légende	Explicación de símbolos
=> 1999999 2000000 => 2003.04 => TI 2003/07 Acc. = { m Corr.	Produktion bis Serien-Nr. Neues Teil ab Serien-Nr. Neues Teil ab Jahr / Monat Siehe Technische Information Jahr / Nr. Zubehör (nicht im Lieferumfang) Keine Serienausführung, jedoch verwendbar Beinhaltet Positions-Nr. Meterware Druckfehlerberichtigung	Production to serial number New part from serial number New part from Year / Month See Technical Information Year / No. Accessories (not included in the delivery inventory) No standard execution, may be used Contains item number Sold by the meter Error correction	Production jusqu'à n° de série Nouveau pièce à partir du n° de série Nouveau pièce à partir de année / mois Voir information technique année / n° Accessoires (non compris dans la livraison) Aucune exécut. en série, cependant utilisable contient n° de numéro Au mètre Rectification d'erreurs	Producción hasta N° de serie Pieza nueva a partir de N° de serie Pieza nueva a partir de año / mes Véase inform. técnico año / N° Accesorios (no incluido en la extensión del suministro) No es de serie, pero sirve Contiene pos N° Por metro Fe de erratas
	Änderungen vorbehalten	Specifications subject to change without notice	Changements sans préavis	Mejoras constructivas sin previo aviso