

MK-370EXP TILE SAW

OWNER'S MANUAL, PARTS LIST & OPERATING INSTRUCTIONS



Revision 307	05.2015
Manual Part No. 160084	

Caution: Read all safety and operating instructions before using this equipment. This owners manual **MUST** accompany the equipment at all times.

TILE SAW ASSEMBLY
PART# 159943

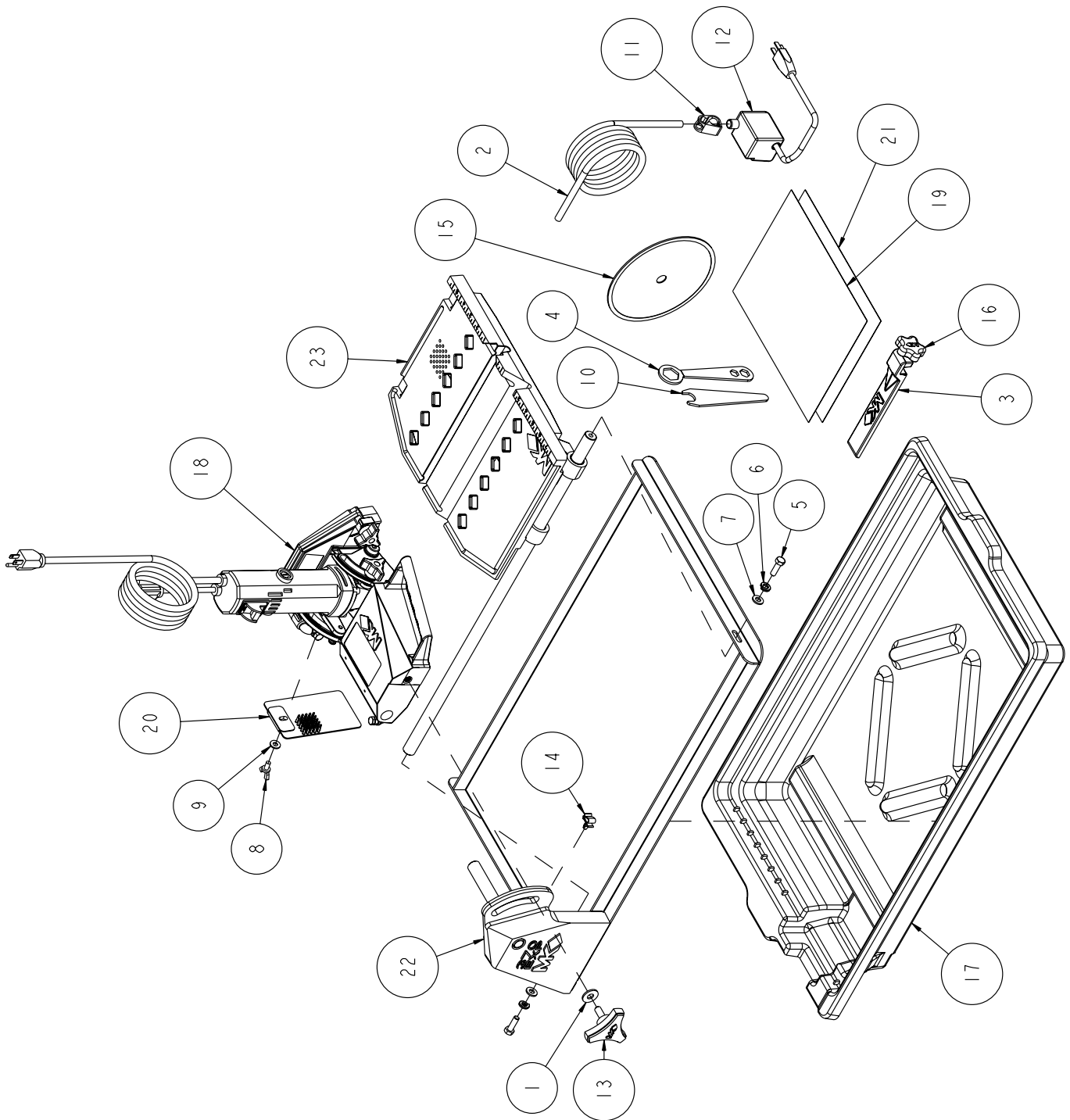

ITEM.	DESCRIPTION	QTY.	PART #
1	WASHER, FLAT CUT 3/8	1	101360
2	HOSE, WATER VINYL 1/2 X 3/8 TSAW (6.0')	1	132951
3	CASTING, ACC RIP GUIDE - COMP	1	134551
4	WRENCH, TILES AW, 15/16 - 18 X 1	2	134684
5	SCREW, HEX HD, 5/16 - 18 X 1	2	151743
6	WASHER, LOCK, SPLIT, 5/16	2	151747
7	WASHER, FLAT, SAE, 5/16	2	151754
8	SCREW, WING, 1/4 - 20 X 1/2	1	151888
9	WASHER, 1/4 SAE FLAT	1	151915
10	WRENCH, TILES AW, 11/16 OPEN END	1	153450
11	CLAMP, HOSE 1/2 - 3/4	1	154394
12	PUMP, WATER, 115V 60HZ	1	155987-VP
13	KNOB, TRI PLASTIC, 1"	1	156770-01
14	CLIP, CORD 1/4" PUSH MOUNT	1	157259
15	MK-HDTCM WET 7 X 060 X 7/8 CONT	1	157913
16	KNOB, RUBBER, 1/4 -20 X 3/4" LONG	1	159428-1
17	PAN, WATER MK-370EXP/1080	1	160041
18	ASSY, CUTTING HEAD, 120V	1	160042
19	OWNERS MANUAL MK-370EXP	1	160084
20	GUARD, SPLASH	1	160310
21	SHEET, WARNING LABELS, TILE SAW	1	166012
22	ASSY, FRAME, 370EXP	1	167450
23	ASSY, TABLE, 370EXP	1	168025

**CUTTING HEAD ASSEMBLY
PART# 160042**

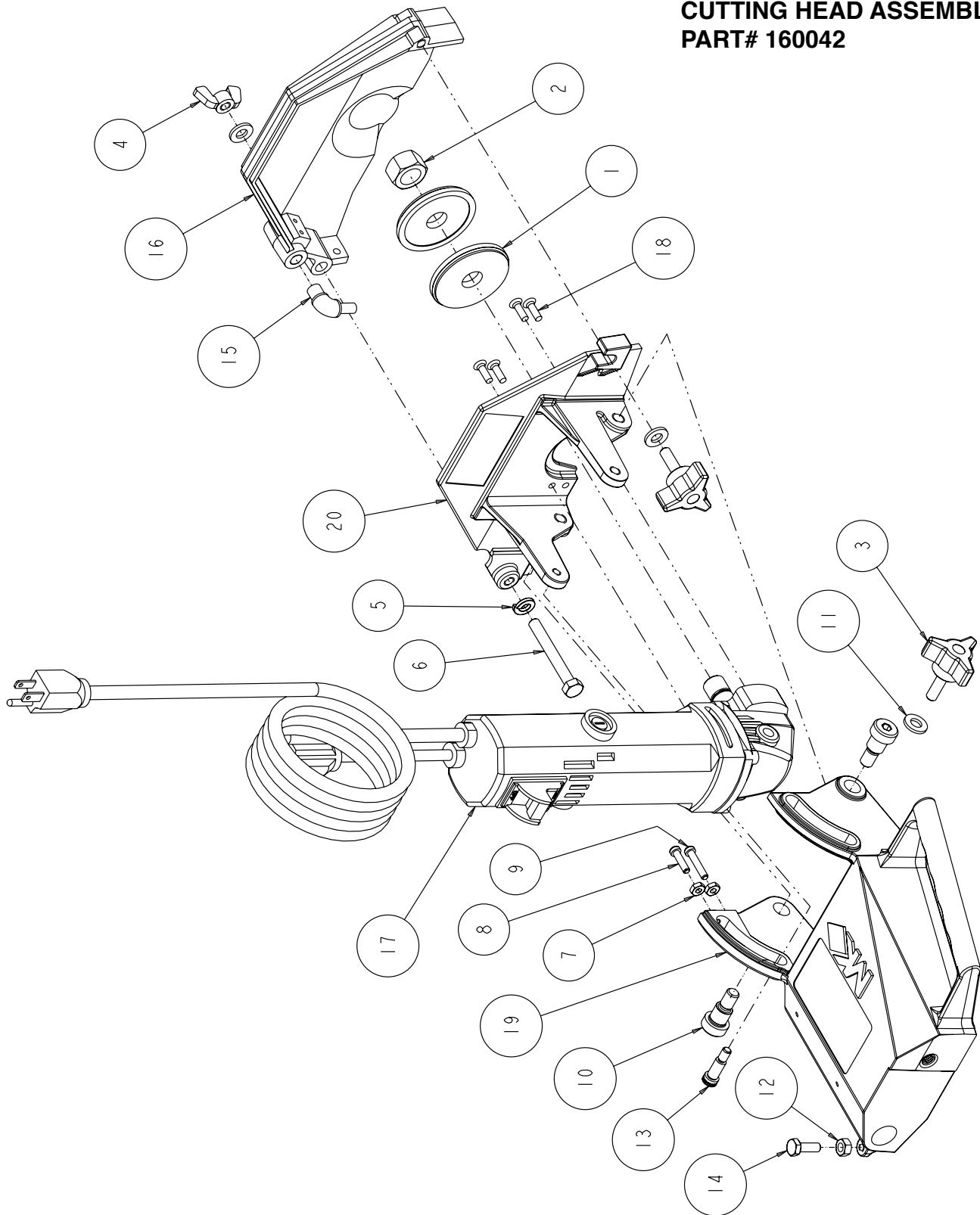

ITEM.	DESCRIPTION	QTY.	PART #
1	FLANGE, OUTER, 2-3/8	2	135830
2	NUT,HEX, 5/8 - 18	1	135848
3	KNOB, DAVIES, 5/16 - 18 X 1	2	151681
4	NUT, WING, NYLK, 5/16 - 18	1	151746
5	WASHER, LOCK, SPLIT, 5/16	1	151747
6	BOLT, HEX HD TAP, 5/16 - 18 X 2 - 1/2	1	151748
7	NUT, HEX, 10-24	2	151749
8	SCREW, FIL HD, SLT, #10 - 24 X 3/4	1	151750
9	SCREW, FIL HD, SLT, #10 - 24 X 1	1	151751
10	SCREW, SHOULDER, 1/2 X 1/2	2	151753
11	WASHER, FLAT, SAE, 5/16	3	151754
12	NUT, HEX, 1/4 - 20	1	1515893
13	SCREW SHOULDER 5/16 X 5/8	1	152137
14	SCREW HEX HD, 1/4 - 20 X 3/4	1	152370
15	ELBOW, 1/8 MNPT X 1/4 BARB 90DEG	1	154652
16	CASTING, BLD GRD, 7 INCH BLADE (COMP)	1	154811
17	MTR, ELECT, 7.4 AMP 120V	1	156428-R
18	SCREW, FLAT HD 10 -32 X 5/8"	4	157554
19	CASTING, COMMON PART, CTTG HD-C	1	159937
20	CASTING, MTR MOUNT, COMMON-COMP	1	159941

**TABLE ASSEMBLY
PART# 168025**

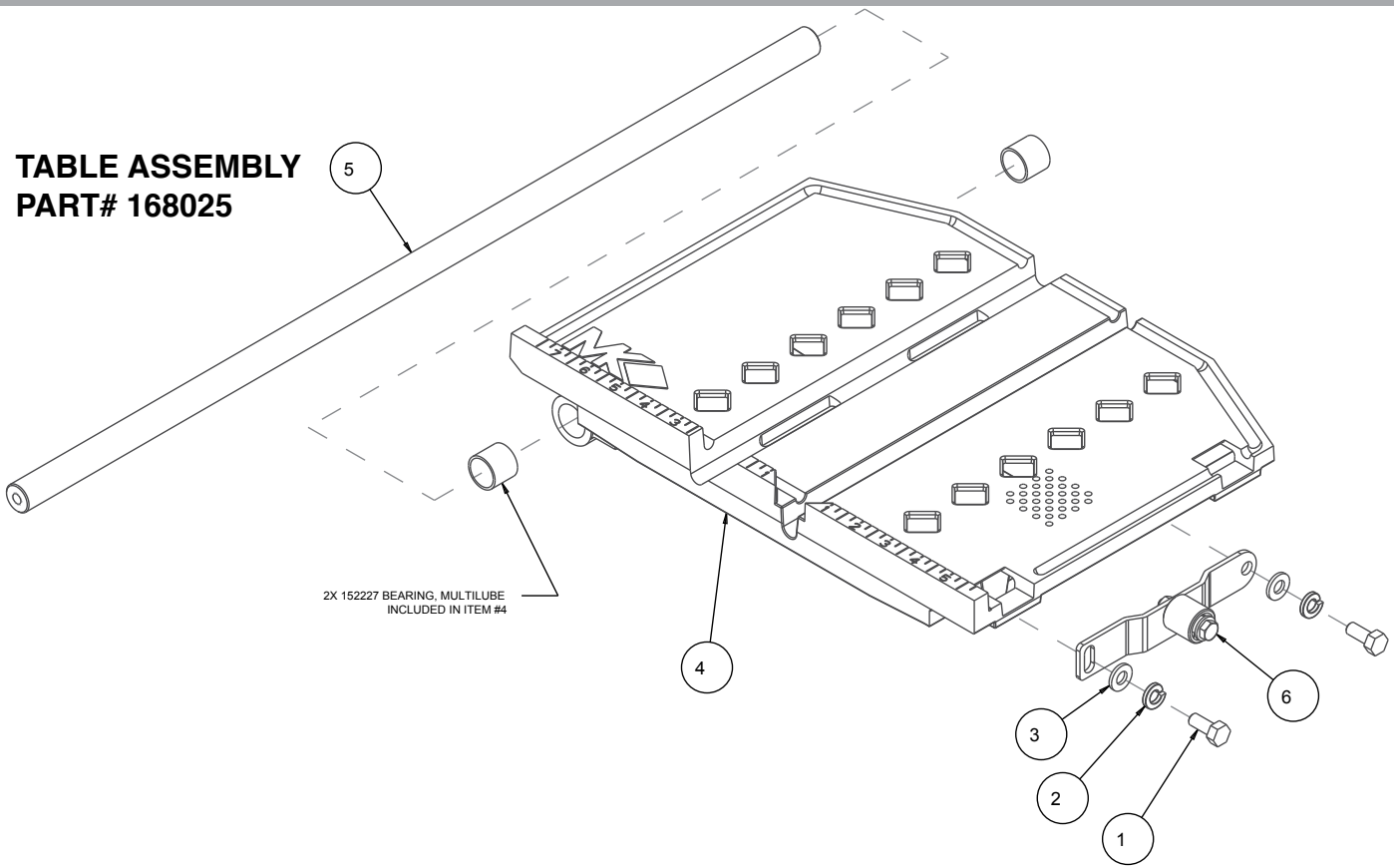

**FRAME ASSEMBLY
PART# 167450**

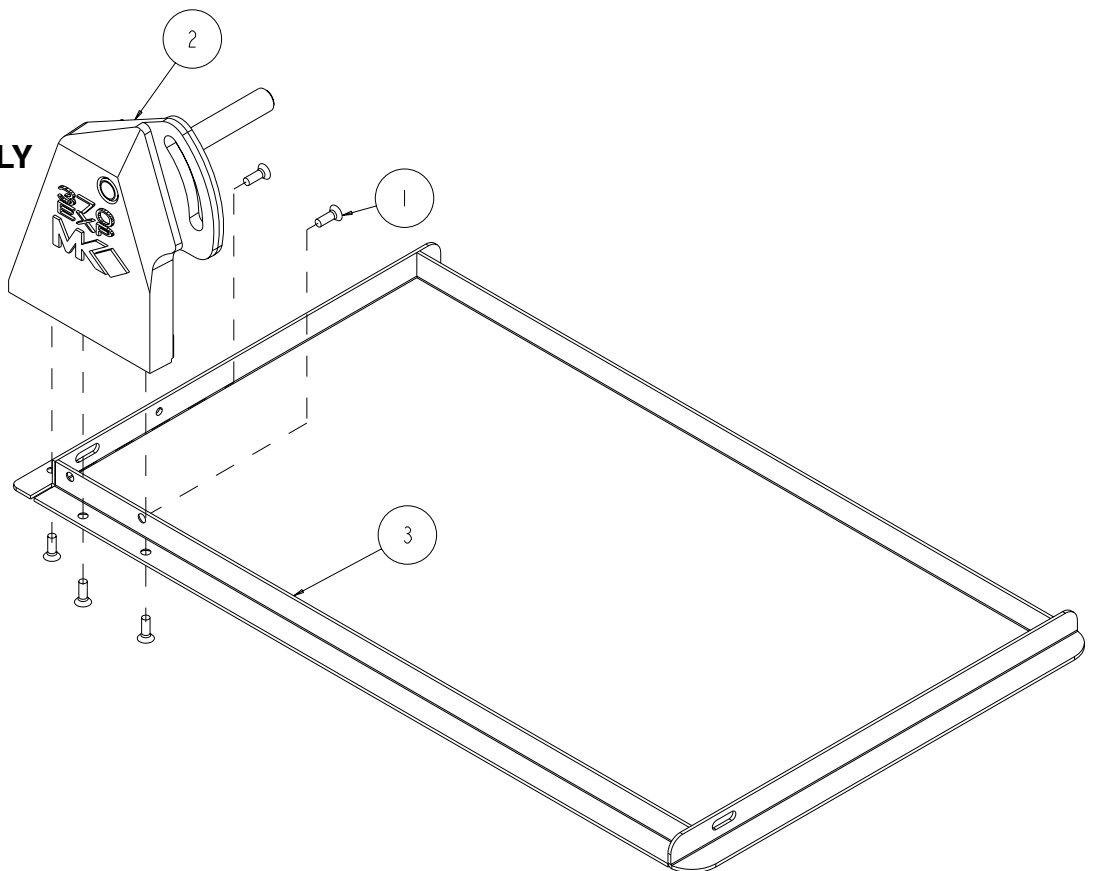

TABLE ASSEMBLY

Item	Description	Part #	Qty
1	SCREW, 5/16-18 X 3/4 HEX HEAD MACHINE	151369	2
2	WASHER, LOCK, SPLIT, 5/16	151747	2
3	WASHER, FLAT, SAE, 5/16	151754	2
4	CASTING, TABLE, 370/770EXP-COMP	159939	1
5	BAR, GUIDE 3/4 DIA	159942	1
6	ASSEMBLY, ROLLER WHEEL	168023	1

FRAME ASSEMBLY

ITEM.	DESCRIPTION	QTY.	PART #
1	SCREW, 1/4 -20 X 3/4 FLAT HEAD PHILLIPS MACHINE	5	154657
2	CASTING, POST MOUNT, COMP	1	167448
3	WELDMENT, FRAME	1	167449

ITEM	NUMBER	DESCRIPTION	
1.	158434	MK-225, 7 x 5/8 Arbor	
2.	139311	MK-215, 7 x 5/8 Arbor	
3.	153293	MK-315, 7 x 5/8 Arbor	
5.	134577-MK	Dual 45° Flat Angle Guide	
6.	134569-MK	90° Protractor	
7.	152792	Dressing Stone	
8.	160488	Side Table	

ORDERING INFORMATION

You may order MK Diamond products through your local MK Diamond distributor or, you may order direct from MK Diamond.

When ordering direct from MK Diamond, please have the following information ready before calling:

- The Model Number of the saw
- The Serial Number of the saw
- Where the saw was purchased and when
- The Part Number for the part(s) being ordered
- The Part Description for the part(s) being ordered

NOTE: There is a \$25.00 minimum order when ordering direct from MK Diamond. A \$6.00 charge will be added to orders having a net billing value under \$50.00. All purchases must be made using VISA, MasterCard or American Express.

All parts may be ordered by calling toll free to – 800 421-5830 or 310 539-5221 and asking for Customer Service. For technical questions, call – 800 474-5594.

RETURN MATERIALS POLICY

To expedite the service relative to the return of a product purchased through MK Diamond, please observe the following:

NOTE: When returning all items, they must have been purchased within the previous twelve (12) months.

- Have the Model Number of the saw
- Have the Serial Number of the saw
- Have the location of where the saw was purchased
- Have the date when the saw was purchased
- Contact Customer Service for approval to return the item(s)
- Obtain a Returned Goods Number (RGA) authorizing the return
- Follow the packaging instructions in the following section
- Ensure your item(s) are prepaid to the destination

For returned items, call toll free to – 800 421-5830 or 310 539-5221 and ask for Customer Service. For technical questions, call – 800 474-5594 or 310 257-2845.

PACKAGING INSTRUCTIONS

- Remove the Cutting Head and Support Angle Assembly
- Dry the saw before shipping
- When packing, include the following: Saw, Diamond Blade, Blade Guard and Support Angle Assembly and Adjustable Cutting Guide (Other Accessories are not required)
- Package the unit in its original container or one of comparable size (do not ship the unit partially exposed)
- Ensure all parts are secured in the packaging to prevent moving

AUTHORIZED SERVICE CENTERS

For quicker repair time, you may contact MK Diamond Customer Service, toll free, at 800 421-5830 or 310 539-5221 for the Authorized Service Center closest to you or visit our web site at www.mkdiamond.com. For technical questions, call – 800 474-5594.

CONTACT:

Please contact MK Diamond Products, Inc. Customer Service Department with any questions you might have regarding distributors, parts or service.

Telephone: **(800) 421-5830**

Fax: **(310) 539-5158**

E-mail: **Customer_Service@MKDiamond.com**

Customer Service Hours: **Monday through Friday, 6AM-4PM PST**

MK Diamond Products, Inc.
1315 Storm Parkway
Torrance, CA 90501

MK DIAMOND PRODUCTS, INC. LIMITED WARRANTY

MK DIAMOND PRODUCTS, INC. will guarantee every machine they build, to be free from defects in material and workmanship for (1) one year from date of purchase. The obligation of MK DIAMOND PRODUCTS, INC. under this warranty is limited to the repair or replacement of any parts which, under normal use, prove to be defective in material or workmanship. The parts involved or the unit in question should be returned to MK DIAMOND PRODUCTS, INC. or to a point designated by us, transportation prepaid.

This warranty does not obligate us to bear the cost of labor or transportation charges in connection with replacement or repair of defective parts. Likewise, it shall NOT apply to any unit which has been subjected to misuse, neglect or accident. This warranty does NOT apply to any machine which has been repaired or altered outside our factory.

This warranty does NOT obligate MK DIAMOND PRODUCTS, INC., with respect to items not of our manufacture, such as engines, motors, hydraulics, etc., which are subject to their own guarantees and warranties.

We shall in no event be liable for consequential damages or contingent liabilities arising out of failure of any equipment or parts to operate properly.

© COPYRIGHT 2013, MK DIAMOND PRODUCTS, INC. ALL RIGHTS RESERVED.

The MK Diamond logo is a registered trademark of MK Diamond Products, Inc. and may not be used, reproduced, or altered without written permission. All other trademarks are the property of their respective owners and used with permission.

MK Diamond may have patents, patent applications, trade marks, copyrights of other intellectual property right covering this product in this document.

This manual MUST accompany the equipment at all times. This manual is considered a permanent part of the equipment and should remain with the unit if resold.

The information and specifications included in this publication were in effect at the time of approval for printing.

MK-370EXP TILE SAW
OWNER'S MANUAL, PARTS LIST
& OPERATING INSTRUCTIONS



MK Diamond Products, Inc.

MK Diamond Products, Inc.
1315 Storm Parkway
Torrance, CA 90501

Toll-Free: (800) 421-5830
Phone: (310) 539-5221
Fax: (310) 539-5158
www.mkdiamond.com