

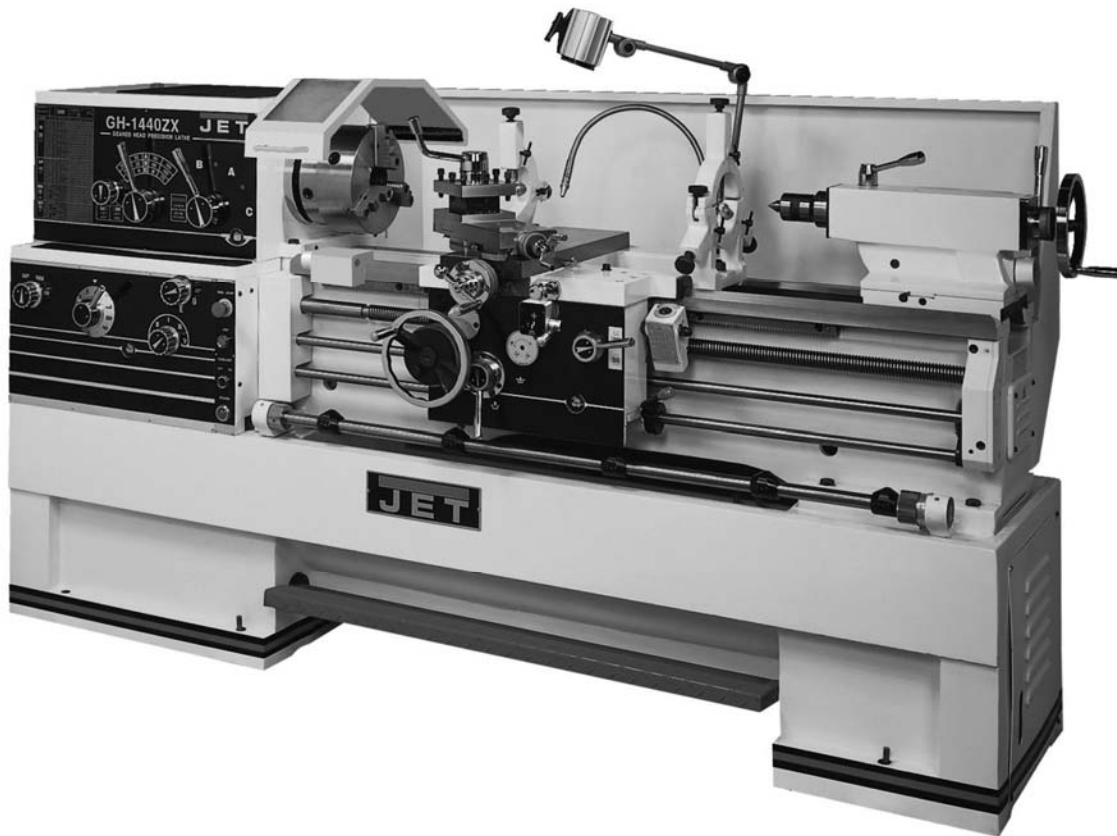

Operation and Maintenance Instructions ZX-Series Large Bore Lathes

Models GH-1440ZX
GH-1640ZX/1660ZX
GH-1860ZX/1880ZX
GH-2280ZX



Model GH-1440ZX shown

*** For ZX-Series Lathes Parts List & Electrical Diagrams, see document M-321910-1**

JET

427 New Sanford Road
LaVergne, TN 37086
Ph.: 800-274-6848
www.jettools.com

Part No. M-321910
Revision I 11/2014
Copyright © 2014 JET

1.0 Warranty and service

JET warrants every product it sells against manufacturers' defects. If one of our tools needs service or repair, please contact Technical Service by calling 1-800-274-6846, 8AM to 5PM CST, Monday through Friday.

Warranty Period

The general warranty lasts for the time period specified in the literature included with your product or on the official JET branded website.

- JET products carry a limited warranty which varies in duration based upon the product. (See chart below)
- Accessories carry a limited warranty of one year from the date of receipt.
- Consumable items are defined as expendable parts or accessories expected to become inoperable within a reasonable amount of use and are covered by a 90 day limited warranty against manufacturer's defects.

Who is Covered

This warranty covers only the initial purchaser of the product from the date of delivery.

What is Covered

This warranty covers any defects in workmanship or materials subject to the limitations stated below. This warranty does not cover failures due directly or indirectly to misuse, abuse, negligence or accidents, normal wear-and-tear, improper repair, alterations or lack of maintenance.

Warranty Limitations

Woodworking products with a Five Year Warranty that are used for commercial or industrial purposes default to a Two Year Warranty. Please contact Technical Service at 1-800-274-6846 for further clarification.

How to Get Technical Support

Please contact Technical Service by calling 1-800-274-6846. **Please note that you will be asked to provide proof of initial purchase when calling.** If a product requires further inspection, the Technical Service representative will explain and assist with any additional action needed. JET has Authorized Service Centers located throughout the United States. For the name of an Authorized Service Center in your area call 1-800-274-6846 or use the Service Center Locator on the JET website.

More Information

JET is constantly adding new products. For complete, up-to-date product information, check with your local distributor or visit the JET website.

How State Law Applies

This warranty gives you specific legal rights, subject to applicable state law.

Limitations on This Warranty

JET LIMITS ALL IMPLIED WARRANTIES TO THE PERIOD OF THE LIMITED WARRANTY FOR EACH PRODUCT. EXCEPT AS STATED HEREIN, ANY IMPLIED WARRANTIES OF MERCHANTABILITY AND FITNESS FOR A PARTICULAR PURPOSE ARE EXCLUDED. SOME STATES DO NOT ALLOW LIMITATIONS ON HOW LONG AN IMPLIED WARRANTY LASTS, SO THE ABOVE LIMITATION MAY NOT APPLY TO YOU.

JET SHALL IN NO EVENT BE LIABLE FOR DEATH, INJURIES TO PERSONS OR PROPERTY, OR FOR INCIDENTAL, CONTINGENT, SPECIAL, OR CONSEQUENTIAL DAMAGES ARISING FROM THE USE OF OUR PRODUCTS. SOME STATES DO NOT ALLOW THE EXCLUSION OR LIMITATION OF INCIDENTAL OR CONSEQUENTIAL DAMAGES, SO THE ABOVE LIMITATION OR EXCLUSION MAY NOT APPLY TO YOU.

JET sells through distributors only. The specifications listed in JET printed materials and on official JET website are given as general information and are not binding. JET reserves the right to effect at any time, without prior notice, those alterations to parts, fittings, and accessory equipment which they may deem necessary for any reason whatsoever. JET® branded products are not sold in Canada by JPW Industries, Inc.

Product Listing with Warranty Period

90 Days – Parts; Consumable items; Light-Duty Air Tools
1 Year – Motors; Machine Accessories; Heavy-Duty Air Tools; Pro-Duty Air Tools
2 Year – Metalworking Machinery; Electric Hoists, Electric Hoist Accessories; Woodworking Machinery used for industrial or commercial purposes
5 Year – Woodworking Machinery
Limited Lifetime – JET Parallel clamps; VOLT Series Electric Hoists; Manual Hoists; Manual Hoist Accessories; Shop Tools; Warehouse & Dock products; Hand Tools

NOTE: JET is a division of JPW Industries, Inc. References in this document to JET also apply to JPW Industries, Inc., or any of its successors in interest to the JET brand.

2.0 Table of Contents

1.0 Warranty and service	2
2.0 Table of Contents	3
3.0 Safety warnings.....	4
4.0 Dimensions and mounting hole centers	5
5.0 Specifications	6
5.1 Specifications: 14-inch lathe.....	6
5.2 Specifications: 16-inch lathe.....	7
5.3 Specifications: 18-inch lathe.....	8
5.4 Specifications: 22-inch lathe.....	9
6.0 General Description and Nomenclature	10
7.0 Unpacking	12
7.1 Contents of shipping container	12
8.0 Installation	13
8.1 Leveling the lathe	13
8.2 Completing installation	13
8.3 Chuck preparation (three-jaw).....	14
8.4 Break-in period	14
9.0 Maintenance/Lubrication	15
10.0 Coolant preparation.....	16
11.0 Electrical connections	16
11.1 Conversion to 460 volt operation	17
12.0 Controls.....	17
13.0 Operation	19
13.1 Tool setup.....	20
13.2 Feed and thread selection.....	20
13.3 Thread cutting	20
14.0 Adjustments	20
14.1 Chuck jaw reversal	20
14.2 Gib adjustments	21
14.3 Tailstock off-set	21
14.4 Removing gap bridge	21
14.5 Installing gap bridge	22
14.6 Belt replacement/adjustment.....	22
14.7 Aligning tailstock to headstock	22
14.8 Cross slide nut adjustment	22
14.9 Shear pin replacement	22
14.10 Steady rest adjustment.....	22
14.11 Follow rest adjustment	23
14.12 Carriage stops	23
15.0 Lubrication schedule and general maintenance.....	24
16.0 Reference tables	25
16.1 Inch Lead And Feed	25



3.0 Safety warnings

1. Read and understand the entire owner's manual before attempting assembly or operation.
2. Read and understand the warnings posted on the machine and in this manual. Failure to comply with all of these warnings may cause serious injury.
3. Replace the warning labels if they become obscured or removed.
4. This lathe is designed and intended for use by properly trained and experienced personnel only. If you are not familiar with the proper and safe operation of a lathe, do not use until proper training and knowledge have been obtained.
5. Do not use this lathe for other than its intended use. If used for other purposes, JET disclaims any real or implied warranty and holds itself harmless from any injury that may result from that use.
6. Always wear approved safety glasses/face shields while using this lathe. Everyday eyeglasses only have impact resistant lenses; they are not safety glasses.
7. Before operating this lathe, remove tie, rings, watches and other jewelry, and roll sleeves up past the elbows. Remove all loose clothing and confine long hair. Non-slip footwear or anti-skid floor strips are recommended. Do **not** wear gloves.
8. Wear ear protectors (plugs or muffs) during extended periods of operation.
9. Some dust created by power sanding, sawing, grinding, drilling and other construction activities contain chemicals known to cause cancer, birth defects or other reproductive harm. Some examples of these chemicals are:
 - Lead from lead based paint.
 - Crystalline silica from bricks, cement and other masonry products.
 - Arsenic and chromium from chemically treated lumber.Your risk of exposure varies, depending on how often you do this type of work. To reduce your exposure to these chemicals, work in a well-ventilated area and work with approved safety equipment, such as face or dust masks that are specifically designed to filter out microscopic particles.
10. Do not operate this machine while tired or under the influence of drugs, alcohol or any medication.
11. Make certain the switch is in the **OFF** position before connecting the machine to the power supply.
12. Make certain the machine is properly grounded.
13. Make all machine adjustments or maintenance with the machine unplugged from the power source.
14. Remove adjusting keys and wrenches. Form a habit of checking to see that keys and adjusting wrenches are removed from the machine before turning it on.
15. Keep safety guards in place at all times when the machine is in use. If removed for maintenance purposes, use extreme caution and replace the guards immediately.
16. Check damaged parts. Before further use of the machine, a guard or other part that is damaged should be carefully checked to determine that it will operate properly and perform its intended function. Check for alignment of moving parts, binding of moving parts, breakage of parts, mounting and any other conditions that may affect its operation. A guard or other part that is damaged should be properly repaired or replaced.
17. Provide for adequate space surrounding work area and non-glare, overhead lighting.
18. Keep the floor around the machine clean and free of scrap material, oil and grease.
19. Keep visitors a safe distance from the work area. **Keep children away.**
20. Make your workshop child proof with padlocks, master switches or by removing starter keys.
21. Give your work undivided attention. Looking around, carrying on a conversation and "horse-play" are careless acts that can result in serious injury.

22. Maintain a balanced stance at all times so that you do not fall or lean against moving parts. Do not overreach or use excessive force to perform any machine operation. Never force the cutting action.
23. Use the right tool at the correct speed and feed rate. Do not force a tool or attachment to do a job for which it was not designed. The right tool will do the job better and safer.
24. Use recommended accessories; improper accessories may be hazardous.
25. Maintain tools with care. Keep cutting tools sharp and clean for the best and safest performance. Follow instructions for lubricating and changing accessories.
26. Do not attempt to adjust or remove tools during operation.
27. Turn off the machine and disconnect from power before cleaning. Use a brush to remove shavings or debris — do not use your hands.
28. Do not stand on the machine. Serious injury could occur if the machine tips over.
29. Never leave the machine running unattended. Turn the power off and do not leave the machine until it comes to a complete stop.
30. Remove loose items and unnecessary work pieces from the area before starting the machine.

Familiarize yourself with the following safety notices used in this manual:

CAUTION This means that if precautions are not heeded, it may result in minor injury and/or possible machine damage.

WARNING This means that if precautions are not heeded, it may result in serious injury or possibly even death.

4.0 Dimensions and mounting hole centers

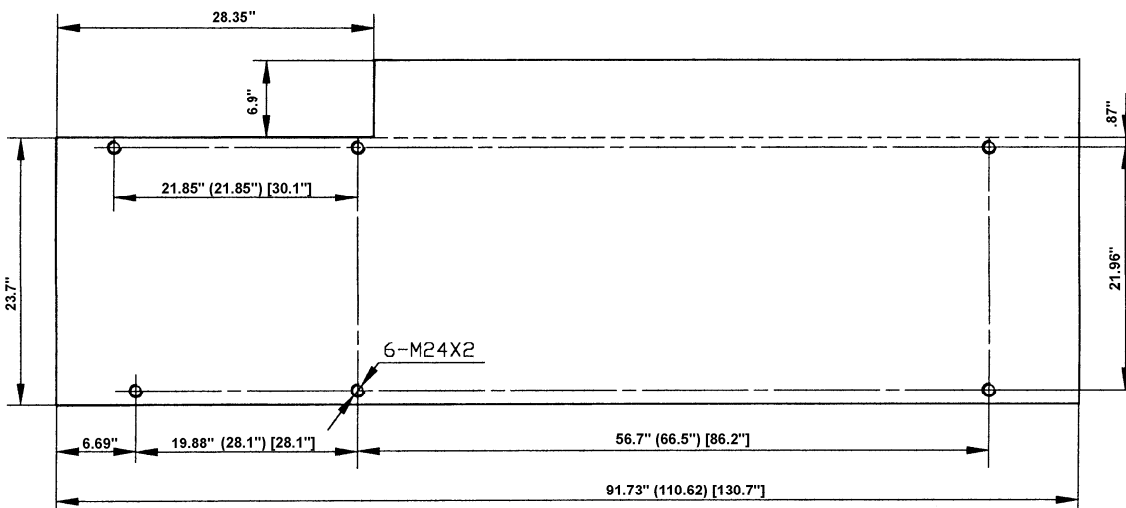

Sizes before () are for 40" Machines Sizes in () are for 60" Machines
 Sizes in [] are for 80" Machines

Figure 1

Specifications were current at the time this manual was published, but because of our policy of continuous improvement, JET reserves the right to change specifications at any time and without prior notice, without incurring obligations.

5.0 Specifications

5.1 Specifications: 14-inch lathe

Model Number **GH-1440ZX**
 Stock Number 321910

Capacities:

Swing over Bed (in.) 14
 Swing over Cross Slide (in.) 7-5/8
 Swing Through Gap (in.) 23-5/8
 Length of Gap (in.) 12-1/4
 Distance between Centers (in.) 40

Headstock:

Spindle Bore (in.) 3-1/8
 Spindle Mount D1-8
 Spindle Taper with Sleeve MT-7(MT-5)
 Number of Spindle Speeds 12
 Range of Spindle Speeds (RPM) 42 to 1800

Gearbox:

Number of Longitudinal and Cross Feeds 122
 Range of Longitudinal Feeds (in./rev.) 0.0015 to 0.0913
 Range of Cross Feeds (in./rev.) 0.0006 to 0.0365
 Number of Inch Threads 61
 Range of Inch Threads (in.) 1-5/8 to 72
 Number of Metric Threads 24
 Range of Metric Threads (mm) 0.05 to 20

Compound and Carriage:

Maximum Tool Size (in.) 1 x 1
 Maximum Compound Slide Travel (in.) 5-1/8
 Maximum Cross Slide Travel (in.) 9
 Carriage Travel (in.) 35

Tailstock:

Tailstock Spindle Travel (in.) 5
 Tailstock Taper MT-4

Steady Rest Capacity (in.) 1/2 to 3-1/2
 Follow Rest Capacity (in.) 3/8 to 7
 Width of Bed (in.) 13-3/8
 Overall Dimensions (in.)(LxWxH) 97-1/2 x 40 x 46-7/8
 Motor 7-1/2HP, 3PH, 230/460V (prewired 230V)
 Approximate Net Weight (lbs.) 5187

5.2 Specifications: 16-inch lathe

Model Number.....	GH-1640ZX	GH-1660ZX
Stock Number	321930.....	321940

Capacities:

Swing over Bed (in.)	16.....	16
Swing over Cross Slide (in.)	10.....	10
Swing Through Gap (in.)	25-7/8.....	25-7/8
Length of Gap (in.)	12-1/4.....	12-1/4
Distance between Centers (in.)	40.....	60

Headstock:

Spindle Bore (in.)	3-1/8.....	3-1/8
Spindle Mount	D1-8.....	D1-8
Spindle Taper with Sleeve	MT-7(MT-5).....	MT-7(MT-5)
Number of Spindle Speeds	12.....	12
Range of Spindle Speeds (RPM)25 to 1800.....	25 to 1800

Gearbox:

Number of Longitudinal and Cross Feeds.....	122.....	122
Range of Longitudinal Feeds (in./rev.)	0.0015 to 0.0913.....	0.0015 to 0.0913
Range of Cross Feeds (in./rev.)	0.0006 to 0.0365.....	0.0006 to 0.0365
Number of Inch Threads	61.....	61
Range of Inch Threads (in.)	1-5/8 to 72.....	1-5/8 to 72
Number of Metric Threads	24.....	24
Range of Metric Threads (mm)	0.05 to 20.....	0.05 to 20

Compound and Carriage:

Maximum Tool Size (in.)	1 x 1.....	1 x 1
Maximum Compound Slide Travel (in.)	5-1/8.....	5-1/8
Maximum Cross Slide Travel (in.)	9.....	9
Carriage Travel (in.)	35.....	55

Tailstock:

Tailstock Spindle Travel (in.)	5.....	5
Tailstock Taper.....	MT-4.....	MT-4

Steady Rest Capacity (in.)	1/2 to 3-1/2.....	1/2 to 3-1/2
Follow Rest Capacity (in.)	3/8 to 7.....	3/8 to 7
Width of Bed (in.)	13-3/8.....	13-3/8
Overall Dimensions (in.)(LxWxH)	97-1/2 x 40 x 48.....	116-1/2 x 40 x 48
Motor	7-1/2HP, 3Ph, 230/460V*.....	7-1/2HP, 3Ph, 230/460V*
Approximate Net Weight (lbs.)	5475.....	5795

*pre-wired 230V

5.3 Specifications: 18-inch lathe

Model Number.....	GH-1860ZX	GH-1880ZX
Stock Number	321960.....	321970

Capacities:

Swing over Bed (in.)	18.....	18
Swing over Cross Slide (in.)	11.....	11
Swing Through Gap (in.)	27-1/2.....	27-1/2
Length of Gap (in.)	12-1/4.....	12-1/4
Distance between Centers (in.)	60.....	80

Headstock:

Spindle Bore (in.)	3-1/8.....	3-1/8
Spindle Mount	D1-8.....	D1-8
Spindle Taper with Sleeve	MT-7(MT-5).....	MT-7(MT-5)
Number of Spindle Speeds	12.....	12
Range of Spindle Speeds (RPM)	25 to 1800.....	25 to 1800

Gearbox:

Number of Longitudinal and Cross Feeds.....	122.....	122
Range of Longitudinal Feeds (in./rev.)	0.0015 to 0.0913.....	0.0015 to 0.0913
Range of Cross Feeds (in./rev.)	0.0006 to 0.0365.....	0.0006 to 0.0365
Number of Inch Threads	61.....	61
Range of Inch Threads (in.)	1-5/8 to 72.....	1-5/8 to 72
Number of Metric Threads	24.....	24
Range of Metric Threads (mm)	0.05 to 20.....	0.05 to 20

Compound and Carriage:

Maximum Tool Size (in.)	1 x 1.....	1 x 1
Maximum Compound Slide Travel (in.)	5-1/8.....	5-1/8
Maximum Cross Slide Travel (in.)	9.....	9
Carriage Travel (in.)	55.....	75

Tailstock:

Tailstock Spindle Travel (in.)	5.....	5
Tailstock Taper.....	MT-5.....	MT-5

Steady Rest Capacity (in.)	1/2 to 3-1/2.....	1/2 to 3-1/2
Follow Rest Capacity (in.)	3/8 to 7.....	3/8 to 7
Width of Bed (in.)	13-3/8.....	13-3/8
Overall Dimensions (in.)(LxWxH)	116-1/2x40x48-7/8.....	136-1/8x40x48-7/8
Motor	7-1/2HP, 3PH, 230/460V*.....	7-1/2HP, 3PH, 230/460V*
Approximate Net Weight (lbs.)	6245.....	6590

*pre-wired 230V

5.4 Specifications: 22-inch lathe

Model Number..... **GH-2280ZX**
Stock Number 321980

Capacities:

Swing over Bed (in.) 22
Swing over Cross Slide (in.) 11
Swing Through Gap (in.) 27-1/2
Length of Gap (in.) 12-1/4
Distance between Centers (in.) 80

Headstock:

Spindle Bore (in.) 3-1/8
Spindle Mount D1-8
Spindle Taper with Sleeve MT-7(MT-5)
Number of Spindle Speeds 12
Range of Spindle Speeds (RPM) 25 to 1800

Gearbox:

Number of Longitudinal and Cross Feeds 122
Range of Longitudinal Feeds (in./rev.) 0.0015 to 0.0913
Range of Cross Feeds (in./rev.) 0.0006 to 0.0365
Number of Inch Threads 61
Range of Inch Threads (in.) 1-5/8 to 72
Number of Metric Threads 24
Range of Metric Threads (mm) 0.05 to 20

Compound and Carriage:

Maximum Tool Size (in.) 1 x 1
Maximum Compound Slide Travel (in.) 5-1/8
Maximum Cross Slide Travel (in.) 9
Carriage Travel (in.) 75

Tailstock:

Tailstock Spindle Travel (in.) 5
Tailstock Taper MT-5

Steady Rest Capacity (in.) 1/2 to 3-1/2
Follow Rest Capacity (in.) 3/8 to 7
Width of Bed (in.) 13-3/8
Overall Dimensions (in.)(LxWxH) 136-1/8 x 40 x 48-7/8
Motor 10HP, 3PH, 230V/460V (pre-wired 230V)
Approximate Net Weight (lbs.) 7400

6.0 General Description and Nomenclature

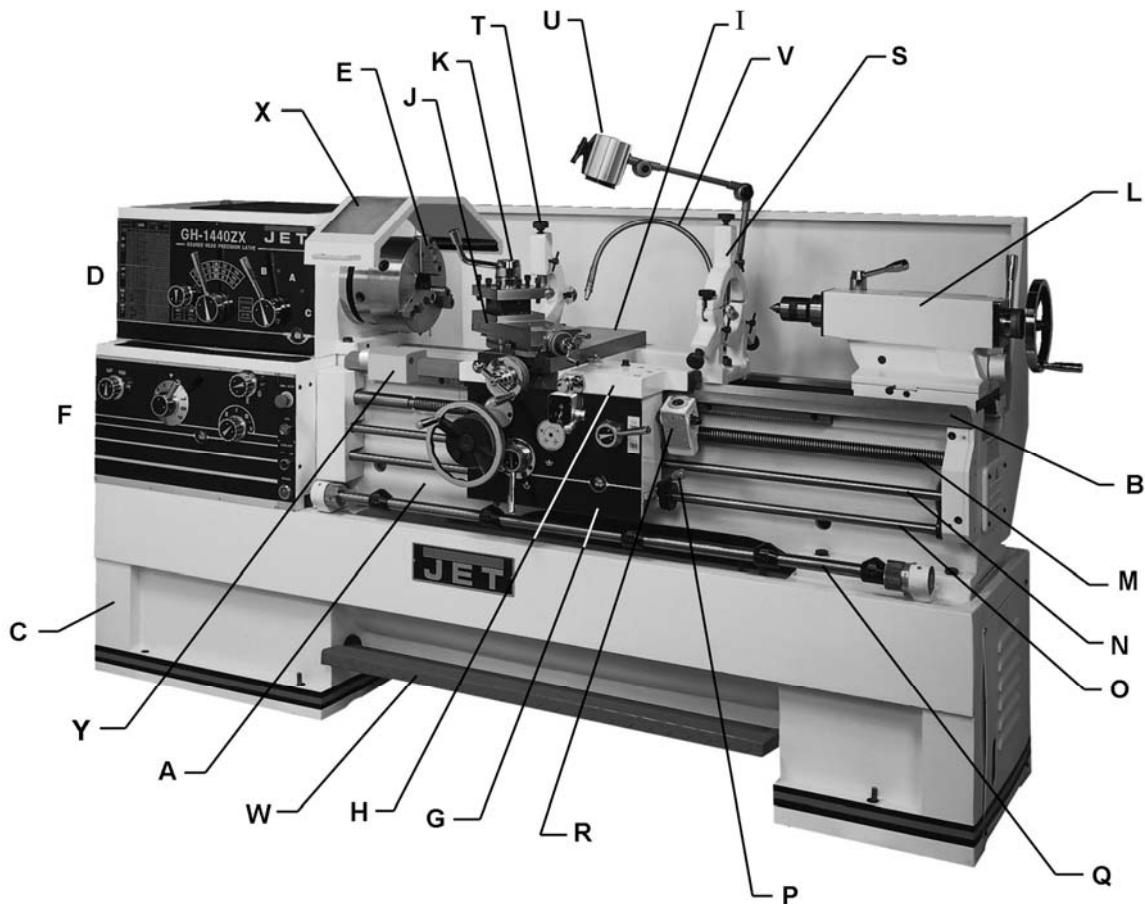

Figure 2 – General Description of ZX Lathes

Bed and stand

The lathe bed (A) is made of cast iron with low vibration and high rigidity. Two precision-ground v-slideways (B), reinforced by supersonic frequency hardening, offer precision guidance for the carriage. The main drive motor is mounted in the stand (C) below the gearbox.

Headstock

The headstock (D) is cast from high grade, low vibration cast iron. In the head, the spindle is mounted in precision taper roller bearings. See *section 12.0* for detailed explanation of controls. The electrical box is mounted to the rear of the headstock.

A 3-Jaw scroll chuck (E) and a 4-jaw independent chuck are included.

Feed gearbox

The gearbox (F) is made from high quality cast iron and is mounted to the left side of the machine bed.

Carriage

The carriage assembly is composed of the *Apron*, the *Saddle*, the *Cross Slide*, the *Compound Rest*, and the four-way *Tool Post*.

Apron (G). Quick travel of the Apron for positioning is accomplished by means of a bed-mounted rack and pinion, operated manually by the handwheel on the front of the apron, or automatically by the feed direction handle.

Saddle (H). The saddle is made from high quality cast iron and rides along the v-ways.

Cross Slide (I). The cross-slide is mounted on the saddle and used for cross feed operations. It moves on a dovetailed slide which can be adjusted for play by means of the gibs.

Compound Rest (J). The compound rest, which is T-slotted and mounted on the cross slide, can be rotated 360°, allowing tapers to be turned. The compound rest travels on dovetailed ways, with adjustable gibs.

Four-Way Tool Post (K). The tool post is a turret design, mounted to the compound rest. It holds up to four tools simultaneously, and includes an indexing function. *(Always use a minimum of two clamping screws when installing a cutting tool.)*

Tailstock

The tailstock (L) slides on a v-way and can be locked at any location by a clamping lever. The tailstock has a heavy duty quill with a No. 4 Morse Taper or No. 5 Morse Taper (18" and 22" models) and etched graduation scale. The tailstock can be offset for taper cutting.

Leadscrew and feed rod

The leadscrew (M) and feed rod (N) are mounted on the front of the machine bed. They are connected to the gearbox at the left and are supported by bearings on both ends. Both are equipped with shear pins.

Spindle direction control axle (O)

Spindle rotation can be reversed by simply moving the control lever (P) mounted at the right of the carriage. (Allow spindle to come to a stop before reversing.)

Travel setting rod (Q)

The stops can be moved and tightened into position at any point along the rod, to limit travel of the carriage.

Thread chaser (R)

Simplifies the process of setting leadscrew/carriage positions in relation to the workpiece, by indicating the point on the leadscrew where the half nut can be reengaged to continue threading.

Steady rest (S)

The steady rest serves as a support for shafts on the free tailstock end. The steady rest is mounted on the bedway and secured from below with a bolt, nut and locking plate.

Follow rest (T)

The traveling follow rest is mounted to the saddle, and thus follows the movement of the turning tool. Only two fingers are required as the place of the third is taken by the turning tool. The follow rest is used for turning operations on long, slender work pieces. It prevents the work piece from flexing under the pressure of the cutting tool.

Work lamp (U)

Adjustable halogen lamp with independent on/off switch.

Coolant nozzle (V)

Fully adjustable gooseneck; flow is regulated through a valve lever at its base.

Foot brake (W)

Activates a braking strap at the motor for emergency stopping of all lathe functions.

Chuck guard (X)

Hinged, with upper and front windows.

Micro stop (Y)

Used for manual carriage operation.

7.0 Unpacking

Open shipping container and check for shipping damage. Report any damage immediately to your distributor and shipping agent. Do not discard any shipping material until the Lathe is assembled and running properly.

Compare the contents of your container with the following parts list to make sure all parts are intact. Missing parts, if any, should be reported to your distributor. Read the instruction manual thoroughly for assembly, maintenance and safety instructions.

7.1 Contents of shipping container

- 1 Lathe
- 1 Steady Rest (mounted on Lathe)
- 1 Follow Rest (mounted on Lathe)
- 1 10" Three Jaw Chuck (mounted on Lathe)
- 1 12" Four Jaw Chuck
- 1 Face Plate (12" Face Plate for 14" & 16" lathes; 16" Face Plate for 18" & 22" lathes)

- 1 Tool Box containing:
 - 1 Open End Wrench Set
 - 1 Hex Wrench Set
 - 1 Morse Reduction Sleeve
 - 1 Center
 - 6 Leveling Bolts with Hex Nuts
 - 6 Leveling Pads
 - 1 Flat Blade Screwdriver
 - 1 Cross Point Screwdriver
 - 1 Chuck Wrench
 - 1 Tool Post Wrench
 - 1 Cam Wrench
 - 1 Adjustable Wrench
 - 1 Round Nut Wrench
 - 1 Oil Gun
 - 1 Cross Feed Handle (not shown)
 - 2 Shear Pins (not shown)
 - 1 Gap Bridge Pin Driver
 - 1 Live Center (MT4 for 14" & 16" lathes; MT5 for 18" & 22" lathes)
 - 1 Operating Instructions Manual
 - 1 Parts List Manual
 - 1 Test Record
 - 1 Warranty Card



Figure 3 - Contents of tool box

WARNING Read and understand the entire contents of this manual before attempting set-up or operation! Failure to comply may cause serious injury.

8.0 Installation

1. Finish removing all crate material from around the lathe.
2. Unbolt lathe from shipping pallet.
3. Choose a location for the lathe that is dry and has sufficient illumination (consult OSHA or ANSI standards for recommended lighting levels in workshop environments).
4. Allow enough room to service the lathe on all four sides, and to load and off-load work pieces. In addition, if bar work is to be performed, allow enough space for stock to extend out the headstock end. If used in production operations, leave enough space for stacking unfinished and finished parts.
5. The foundation must be solid to support the weight of the machine and prevent vibration, preferably a solid concrete floor.
6. Sling the lathe as shown in Figure 4, using steel rods or pipes of sufficient strength inserted through the holes in the bed casting. **Do not lift lathe by the spindle.** With adequate lifting equipment, slowly raise the lathe off the shipping pallet. Make sure lathe is balanced before moving.

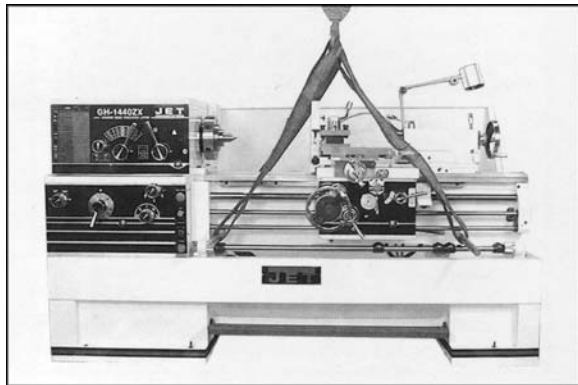

Figure 4: Lifting the lathe

CAUTION Confirm that all suspension equipment is properly rated and in good condition for lifting lathe. Do not allow anyone beneath or near load while lifting.

7. The lathe can be placed upon the cast iron leveling pads under each foot hole, and adjusted using the adjusting bolts with hex nuts. Or, it may be secured to the floor using bolts placed head-down in the concrete, and using shims where needed to level the machine. Refer to Figure 1 for mounting hole dimensions.

8.1 Leveling the lathe

It is imperative that the lathe be on a level plane; that is, where headstock and tailstock center points remain aligned throughout the tailstock travel, with the bed ways absent of twist and thus parallel to the operational center line.

A lathe which is not properly leveled will be inaccurate, producing tapered cuts. Also, the center point of the tailstock will vary as it is positioned along the bed, thus requiring constant readjustment of the set of the tailstock.

8. Use a machinist's precision level on the bed ways both front to back and side to side, as shown in Figure 5. Take the reading in one direction every ten inches. Make sure the ways are clean and free of any debris before placing a level upon them.
9. Deviation over bed length (see Figure 5):
 - a) Maximum 0.02/1000mm
 - b) Maximum 0.04/1000mm

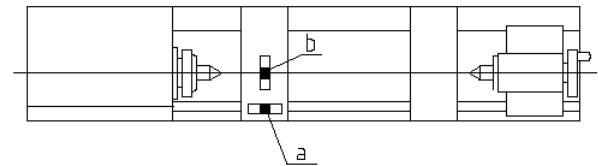

Figure 5: Leveling

10. Tighten foot screw nuts evenly to avoid distortion.
11. Leveling should be inspected occasionally, and especially if the accuracy of the lathe begins to diminish.

8.2 Completing installation

12. Clean all rust protected surfaces using a mild commercial solvent, kerosene or diesel fuel. Do not use paint thinner, gasoline, or lacquer thinner. These will damage painted surfaces. Cover all cleaned surfaces with a light film of 20W machine oil.
13. Open the end gear cover. Clean all components of the end gear assembly and coat all gears with a heavy, non-slinging grease. Close the end gear cover.

8.3 Chuck preparation (three-jaw)

⚠WARNING Read and understand all directions for chuck preparation. Failure to comply may cause serious personal injury and/or damage to the lathe.

The three-jaw scroll chuck is shipped pre-installed on the lathe. It can be used for clamping cylindrical, triangular and hexagonal stock, and has reversible jaws.

The four-jaw chuck has independently adjustable jaws, and permits the holding of square and asymmetrical pieces. It also enables accurate concentric set-up of cylindrical pieces.

Before removing a chuck, place a flat piece of thick plywood across the bedways under the chuck to prevent damage to the bedways should the chuck fall from your hands. Alternatively, many users make a wood chuck cradle that sits atop the ways and accepts the specific diameter of chuck, for easier installing and removal. Figure 6 shows an example.

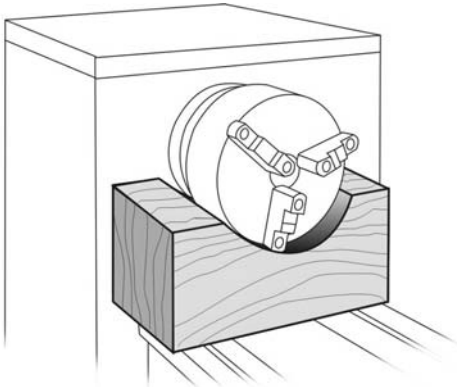

Figure 6: Chuck cradle

To remove the chuck:

1. Support the chuck while turning six camlocks 1/4 turn counterclockwise with the chuck wrench from the tool box.
2. Carefully remove the chuck from the spindle and place on an adequate work surface.
3. Inspect the camlock studs. Make sure they have not become cracked or broken during transit. Clean all parts thoroughly with solvent. Also clean the spindle and camlocks.
4. Cover all chuck jaws and scroll inside the chuck with #2 lithium tube grease. Cover the spindle, camlocks, and chuck body with a light film of 20W oil.
5. Lift the chuck up to the spindle nose and press onto the spindle. Tighten in place by turning the camlocks 1/4 turn clockwise. The index mark (A, Figure 7) on the camlock should be between the two indicator arrows (B) when tight, as shown in Figure 7.

- If the index mark (A) is *not* between the two arrows, i.e. the cam turns beyond the indicator arrows, then remove the chuck and turn the camlock stud IN one full turn.
- If a camlock will not engage, remove the chuck and turn the camlock stud OUT one full turn.

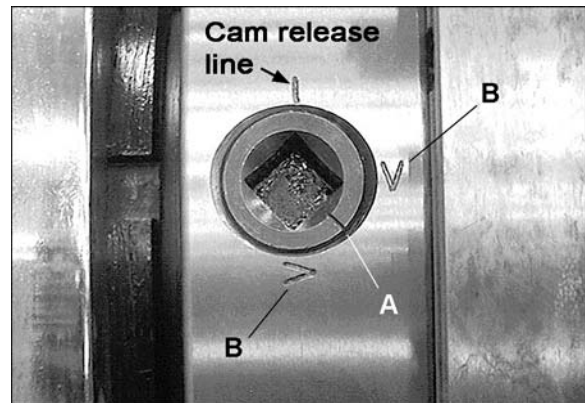

Figure 7: Camlock

6. Make sure chuck is secure on the spindle with the camlocks correctly engaged.

8.4 Break-in period

Do not run the lathe above 560 RPM for the first six hours of operation, to allow gears and bearings to adapt and run smoothly.

9.0 Maintenance/Lubrication

CAUTION Lathe must be serviced at all lubrication points and all reservoirs filled to operating level before the lathe is put into service. Failure to comply may cause serious damage to the lathe.

The ZX series lathe is shipped with oil in the reservoirs. Coolant is not included.

Use clean lubricants and check levels often, including before each working shift. To ensure proper lubrication, oil levels should not be less than the center of the oil sight glass. Try not to overfill, as this may cause leakage.

A chart is supplied in *section 15.0* for quick reference to all lubrication points.

Unless specified otherwise, the lubrication points require a non-detergent, ISO 68, SAE 20W oil. The recommended brand for this lathe is **Mobil DTE® Oil Heavy Medium**.

1. **Chuck** – In addition to the lubrication already described in *section 8.3*, daily lubricate the chuck with SAE 20W oil through the ball oiler, shown in Figure 8.

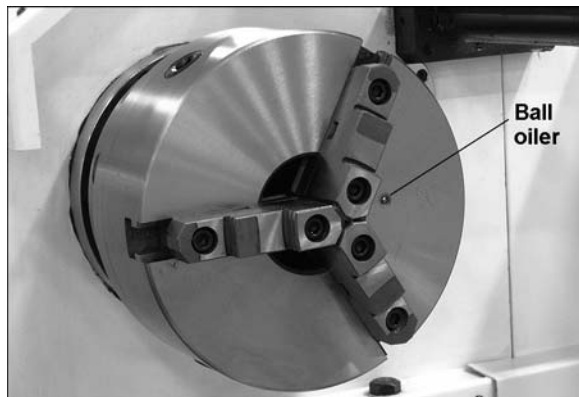

Figure 8

2. **Headstock** – Oil must be up to indicator mark in oil sight glass (A, Figure 9). Top off with SAE 20W. Fill by removing the plug on top of the headstock. To drain, remove drain plug on the left side of the headstock at the lower rear corner. Drain oil completely and clean out all metal shavings. Refill after the first month of operation. Then change the oil in the headstock every two months.
3. **Gearbox** – Oil must be up to indicator mark in oil sight glass (B, Figure 9). Top off with SAE 20W. To add oil to the gearbox, remove two screws on the top cover and remove cover. To drain, remove drain plug (C, Figure 9) on the left side of the gearbox. Drain oil completely and refill after the first three months of operation. Then change oil in the gearbox every six months.

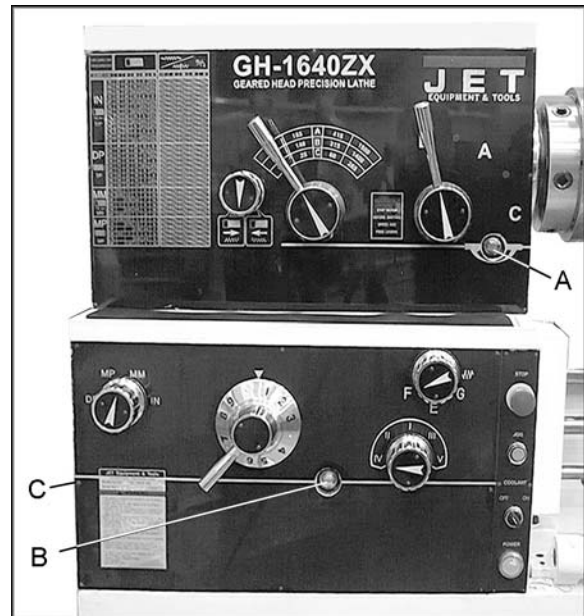

Figure 9

4. **Apron** – Oil must be between indicator marks in the oil sight glass (A, Figure 10). Top off with SAE 20W. Remove oil plug (B, Figure 10) to fill. To drain, remove drain plug on bottom of apron.

Drain oil completely and refill after the first three months of operation. Then, change oil in the apron annually. Pull knob (C, Figure 10) on the one-shot lube system and hold for several seconds to allow oil to fill the pump. When the knob is released, oil will flow through various oil lines to lubricate the ways and cross slide surface. Perform this twice daily or as needed. When the oil level is below the indicator mark, oil must be added.

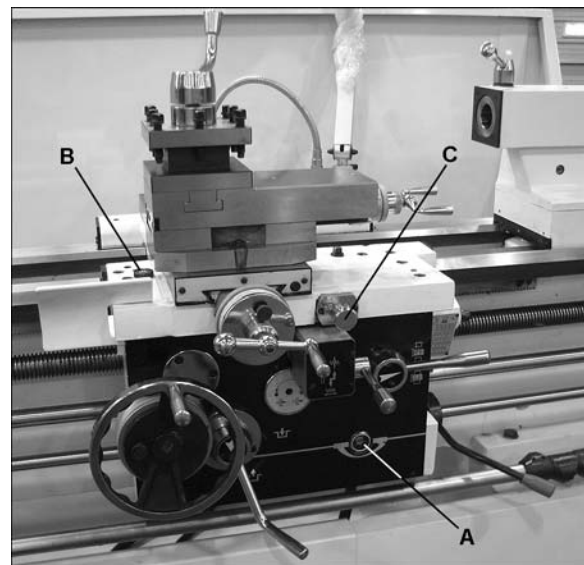

Figure 10

5. **Leadscrew and Feed Rod** – Daily lubricate two ball oilers on the right side bracket (A, Figure 11) with SAE 20W once or twice per shift.

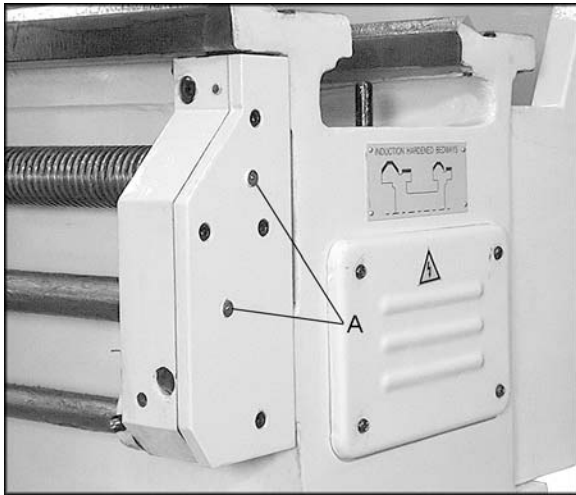

Figure 11

Saddle – Daily lubricate ball oiler (A, Figure 12) on handwheel shaft with SAE 20W.

The anti-dust felt on both ends of the saddle where it contacts the ways should be cleaned weekly with kerosene. If the felt becomes damaged, replace it.

6. **Compound Rest** – Daily lubricate two ball oilers (B, Figure 12) on top of compound rest with SAE 20W.
7. **Cross Slide** – Daily lubricate one ball oiler (C, Figure 12 – opposite side) with SAE 20W.
8. **Toolpost** – Daily lubricate one ball oiler (D, Figure 12) with SAE 20W.

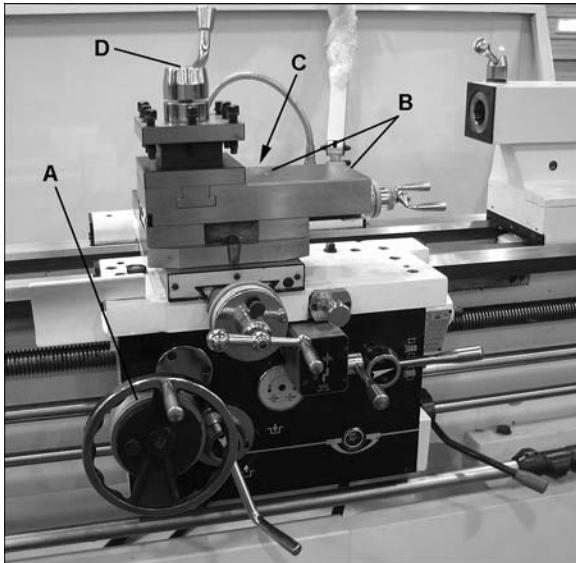

Figure 12

9. **Tailstock** – Daily lubricate one ball oiler (A, Figure 13) on top of tailstock with SAE 20W.

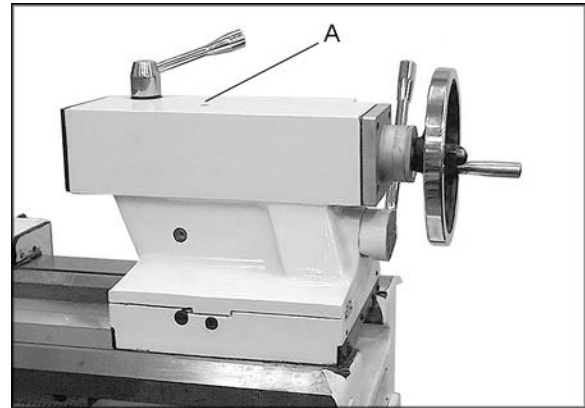

Figure 13

10. **V-Belts** – Regularly check and adjust the tightness of the v-belts to prolong their service life. See section 14.6, *Belt replacement and adjustment*.

10.0 Coolant preparation

CAUTION Follow coolant manufacturer's recommendations for use, care and disposal.

1. Remove access cover on tailstock end at the rear base of the lathe. Make sure coolant pump has not shifted during transport.
2. Pour four gallons (approximate) of coolant mix into the chip pan.
3. After machine has been connected to power, turn on coolant pump and check to see that coolant is cycling properly.
4. Replace access cover.

11.0 Electrical connections

WARNING Electrical connections must be made by a qualified electrician in compliance with all relevant codes. This machine must be properly grounded while in use to help protect the operator from electrical shock and possible fatal injury.

The main motor is rated at 7-1/2 HP (or 10HP for model 2280ZX), 230/460V and comes from the factory prewired at 230V. Confirm that power available at the lathe's location is the same rating as the lathe.

Power is connected properly when rotation of the forward-reverse knob (see E, Figure 15) to the left position causes the spindle to rotate counterclockwise as viewed from the tailstock. If the chuck rotates in the clockwise direction, disconnect the lathe from the power source, switch any two of the three power leads (not the green ground wire), and re-connect the lathe to the power source.

11.1 Conversion to 460 volt operation

⚠WARNING Disconnect machine from power source. Failure to do so may cause serious injury.

Main Motor: Change the wires according to the diagram on the outside of the motor junction box.

Transformer: Open electrical panel on rear of machine on the headstock side. Switch wire from 230V terminal to 460V terminal as outlined on the transformer.

Coolant Pump: Open access panel on the base at the tailstock end. Change wires in coolant pump junction box according to diagram on the outside of the junction box cover.

Main Power Switch (A, Figure 14): Turns power to machine on and off.

Power Source Cable Receiver (B, Figure 14).

Make sure the lathe is properly grounded.



Figure 14: Power input

12.0 Controls

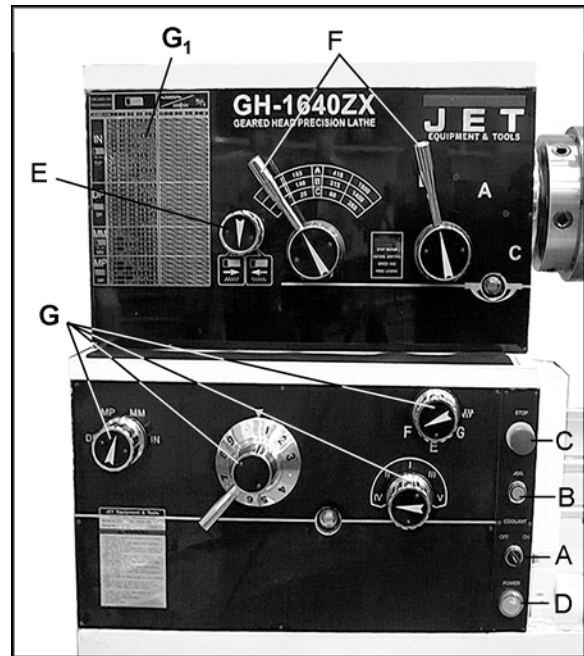

Figure 15 – Headstock controls

1. **Control Panel:** located on front of headstock.
 - **Coolant On-Off Switch (A, Figure 15)** turns coolant pump on and off.
 - **Power Indicator Light (D, Figure 15)** is lit whenever lathe is receiving power.
 - **Emergency Stop Switch (C, Figure 15)** stops all machine functions (**Caution:** Lathe will still have power). Twist clockwise to re-set.
 - **Jog Switch (B, Figure 15).** Quickly press and release to rotate the spindle.
 2. **Headstock Gear Change Levers (F, Figure 15):** Move levers left or right to desired spindle speed, according to accompanying chart.
 3. **Leadscrew/Feed Rod Directional Dial (E, Figure 15):** Changing knob changes direction of feed.
- ⚠CAUTION** Do not move knob (E) while machine is running.
4. **Feed/Lead Selector Levers (G, Figure 15):** Used conjunctively to set up for threading or feeding, according to the accompanying chart (G₁, Figure 15).

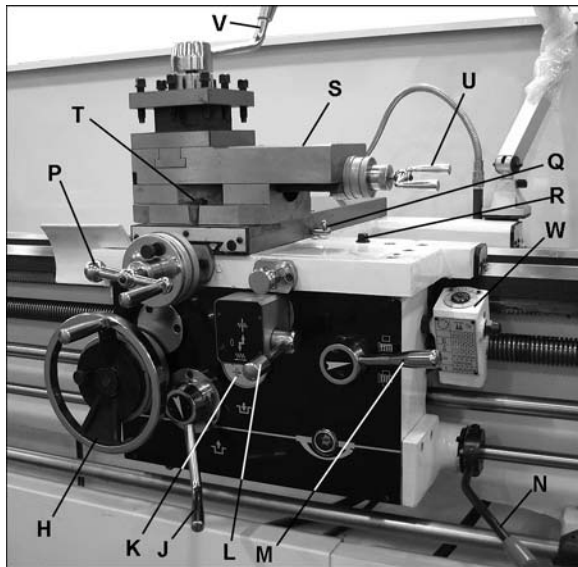

Figure 16 – Carriage controls and settings

5. **Carriage Handwheel (H, Figure 16):** Located on apron assembly. Rotate handwheel clockwise to move carriage toward tailstock (right). Rotate handwheel counterclockwise to move carriage toward headstock (left).
6. **Feed Engagement Lever (J, Figure 16):** Located on front of apron assembly. Pull lever up to engage. Push lever down to disengage.
7. **Adjustable Feed Clutch (K, Figure 16):** When the machine is overloaded, it can slip. Then cutting rate must be reduced. **Note:** This setting has been calibrated at the factory and should not need adjustment. If adjustment ever becomes necessary, follow the diagram on the front of the apron.
8. **Longitudinal/Cross Feed Selector Lever (L, Figure 16):** Can be pushed to upper, middle and lower three positions. Push the lever up, cross feed is effected. Push the lever down, longitudinal feed is effected. When the lever is in the middle position, screws can be cut by engaging the half nut.
9. **Half Nut Lever (M, Figure 16):** Located on front of apron assembly. Used for threading.
10. **Spindle Direction Control Lever (N, Figure 16):** Move lever to the right so that its tab clears the notch, then *downward* for forward spindle rotation, or *upward* for reverse spindle rotation. **Allow spindle to come to a stop before changing directions.** Position lever in neutral position (tab in notch) before shutting off the lathe.
11. **Cross Slide Handwheel (P, Figure 16):** Located above the apron assembly. Clockwise rotation moves cross slide toward rear of machine.

12. **Cross Slide Lock (Q, Figure 16):** Lever located on left side of cross slide. Turn clockwise to lock and counterclockwise to unlock.
13. **Carriage Lock (R, Figure 16):** Located on top right of carriage. Turn clockwise to lock, counterclockwise to unlock.

CAUTION Carriage lock must be loose before moving carriage or damage to lathe may occur.

14. **Compound Rest (S, Figure 16)** is located on top of cross slide and can be rotated 360°. There are calibrations in degrees (T, Figure 16) below the rest to assist in placement of the compound rest to the desired angle.
15. **Compound Rest Handle (U, Figure 16):** Located on end of compound slide. Rotate clockwise or counterclockwise to position.
16. **Compound Lock (not shown):** Lever located on back of compound rest. Turn clockwise to lock and counterclockwise to unlock.
17. **Tool Post Clamping Lever (V, Figure 16):** Located on top of tool post. Rotate counterclockwise to loosen and clockwise to tighten.
18. **Thread Chaser (W, Figure 16):** Indicates the point on the leadscrew where the half nut can be re-engaged to continue inch threading.
19. **Tailstock Quill Clamping Lever (A, Figure 17):** Located on the tailstock. Rotate clockwise to lock the sleeve. Rotate counterclockwise to unlock.

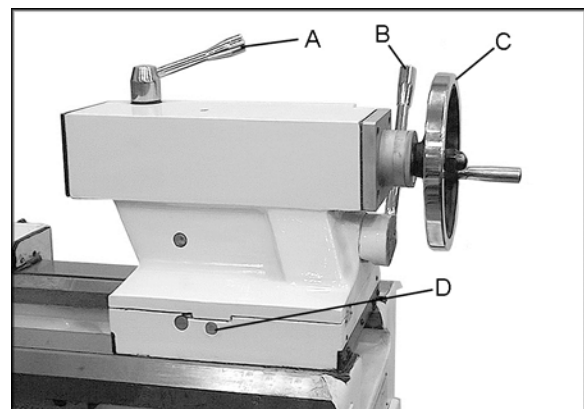

Figure 17 – Tailstock controls

20. **Tailstock Clamping Lever (B, Figure 17):** Lift up to lock. Push down to unlock. If the tailstock has a heavy load, tighten the hexagon head at right side of tailstock for auxiliary locking.
21. **Tailstock Quill Handwheel (C, Figure 17):** Rotate clockwise to advance quill and counterclockwise to retract it.

22. **Tailstock Off-Set Adjustment** (D, Figure 17): Two hex socket cap screws located on the tailstock base are used to off-set the tailstock for cutting tapers. Loosening one screw while tightening the other will off-set the tailstock. Do not clamp the tailstock lock handle when adjusting.

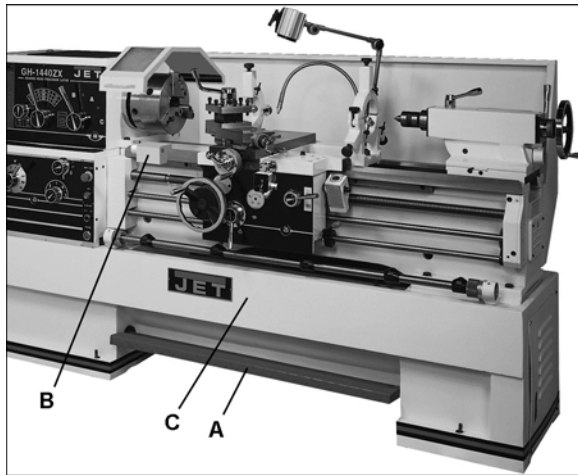

Figure 18 – Other controls

23. **Foot Brake** (A, Figure 18): The connecting rod mechanism is in the bed stand. The braking device is in the pulley of the headstock. Press the pedal to stop all lathe functions. (**Caution:** Lathe still has power.)
24. **Micro Carriage Stop** (B, Figure 18): can be used during manual feed operation. The dial can be turned for fine tuning the position of the stop. The micro carriage stop can be moved along the bed by loosening the two socket head cap screws underneath the stop.
25. **Bed Cover** (C, Figure 18): can be easily removed to clean out the stand.

13.0 Operation

The operator should consult shop manuals such as “Machinery’s Handbook” for cutting speeds and feeds appropriate to specific workpieces. Correct feed depends upon material to be cut, cutting operation, tool type, chucking rigidity, depth of cut, and desired surface quality.

IMPORTANT: Allow a break-in period for the new lathe so that gears and bearings can adapt; do not run the lathe above 560 RPM for the first six hours of operation.

CAUTION

The following points must be observed when operating the lathe:

- Never turn any handles or levers when spindle is at high speed.
- Change spindle speed only after spindle stops.
- Change feed rate only when spindle is at low speed or is stopped.

- Never exceed maximum speed limitation of the work holding device.
- Before starting spindle, check that each handle or lever is at correct position to ensure normal engagement of gears. The spindle direction control lever should be at neutral position.
- If the brake becomes ineffective, turn off machine and adjust brake immediately.
- When operating spindle direction control lever, always turn it to correct position; never use “pre-position” for cutting at a reduced speed.
- Jaw teeth and scroll must be fully engaged, to prevent the jaws from breaking and being thrown from chuck (see Figure 19).

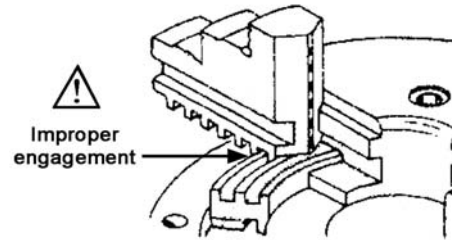

Figure 19 – Insufficient jaw tooth engagement

- Avoid long workpiece extensions, as parts may bend or fly off (see figure 20). Use rests or the tailstock for support.

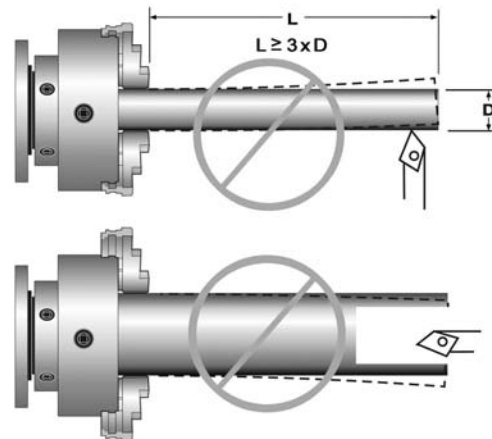

Figure 20 – Improper setups

- Avoid short clamping contact (Figure 21, A) or clamping on a minor part diameter (Figure 21, B). Face-locate the workpiece for added support.

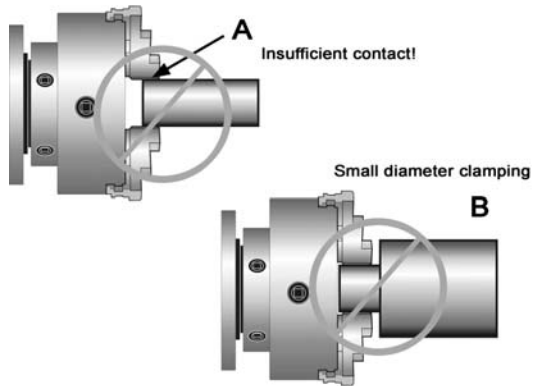

Figure 21 – Improper setups

13.1 Tool setup

The cutting angle is correct when the cutting edge is in line with the center axis of workpiece. Use the point of the tailstock center as a gauge and shims under the tool to obtain correct center height.

Use a minimum of two clamping screws to secure each tool.

13.2 Feed and thread selection

1. Reference the feed and thread chart on the front of the headstock (A, Figure 22).
2. Move levers and knobs (B/C/D/E, Figure 22) to the appropriate position according to the feed and thread chart.

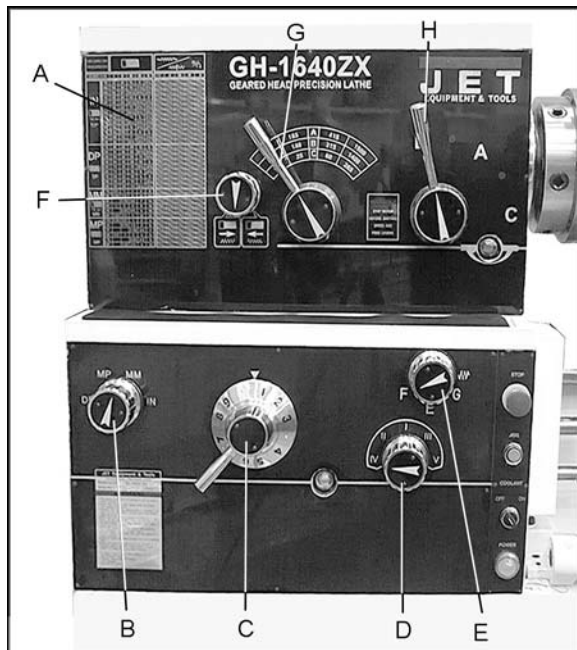

Figure 22

13.3 Thread cutting

1. Set forward/reverse lever (F, Figure 22) to desired direction.
2. Set selector levers (G/H, Figure 22) to desired R.P.M.

3. Select desired thread using levers (B/C/D/E, Figure 22).
4. Set selector lever (A, Figure 23) to correct position (neutral).
5. Engage the half nut lever (B, Figure 23).
6. Make a test cut with scrap material and check results before cutting regular material.

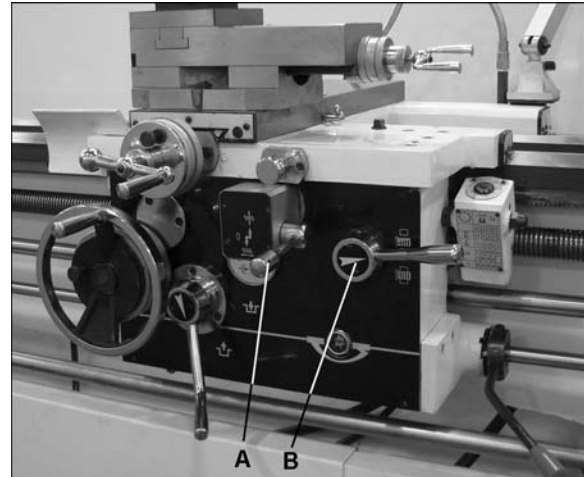

Figure 23

14.0 Adjustments

CAUTION Adjustments to the lathe, especially those involving alignments of bearings, spindle, leadscrew, clutch, etc., should only be performed by qualified personnel, as improper alignments can damage the machine and/or create a safety hazard.

WARNING Turn off main switch and press emergency stop button before making adjustments to lathe.

14.1 Chuck jaw reversal

The three jaws on the scroll chuck are reversible, to hold stock with larger diameters. See Figure 24. Loosen two screws with the provided hex key, remove jaw, and rotate it 180-degrees. Re-install jaw, and tighten each screw in increments until fully tightened.

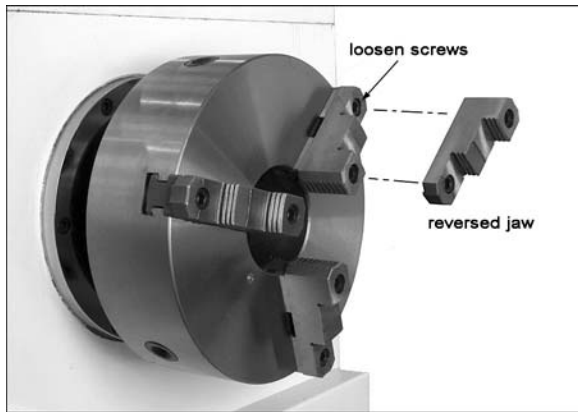

Figure 24 – Chuck jaw reversal

14.2 Gib adjustments

After a period of time, some moving components may need adjustment for play (or “backlash”) due to wear. *Do not overtighten gib screws as this can hasten wear to components.*

14.2.1 Saddle

Turn gib screws on either side of the saddle at the rear to adjust the drag on the saddle.

14.2.2 Cross slide

Gib screws are located at front and rear of slide opposite to one another (A, Figure 25). To adjust drag, loosen rear gib screw one turn, and tighten front gib screw a quarter turn. Rotate handwheel to check play. Repeat as needed until slide moves freely without play. Gently tighten rear gib screw.

14.2.3 Compound rest

Gib screws are located at front and rear of compound rest (B, Figure 25). To adjust, use same method as for Cross Slide.

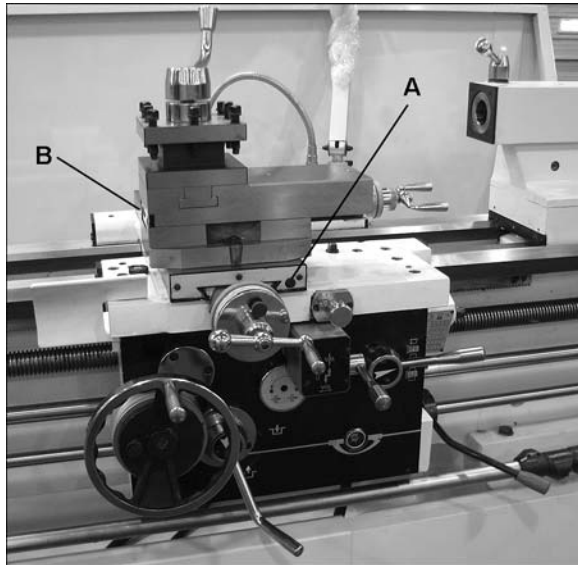

Figure 25 – Gib adjustments, slide and rest

14.2.4 Half Nut

Gib screws are located on right side of apron (C, Figure 26). Loosen the jam nuts and rotate the screws clockwise until any backlash is corrected. Then re-tighten nuts.

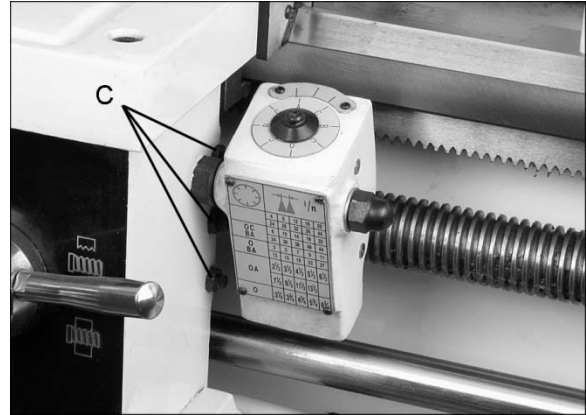

Figure 26 – Half nut gib adjustment

14.3 Tailstock off-set

Follow the procedure below to off-set the tailstock to cut shallow tapers:

1. Loosen tailstock in position by lowering locking handle (B, Figure 27) and loosening hexagon head eccentric shaft at back of tailstock.
2. Alternately loosen and tighten front and rear screws (D, Figure 27). **Note:** Front screw is shown.

The scale on the end of the tailstock base indicates amount of offset, and helps when re-centering.

If clamping force needs to be adjusted, use the hex nut beneath the tailstock body.

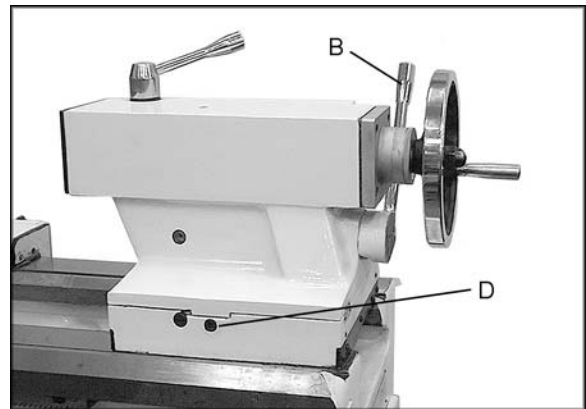

Figure 27 – Tailstock offset

14.4 Removing gap bridge

1. To remove the gap bridge, remove four hex socket cap screws, and two hex cap bolts.
2. Tighten the hex nuts on the tapered alignment pins to loosen the pins. Once loosened, they can be removed.
3. Gap bridge can now be removed.

14.5 Installing gap bridge

1. Clean the bottom and the ends of the gap bridge thoroughly.
2. Set gap bridge in place and align the ends.
3. Loosen the nuts on the locating pins and push down through the gap into the lathe bed.
4. Replace four hex socket cap screws and tighten alternately until all are snug.

14.6 Belt replacement/adjustment

1. Disconnect machine from power source.
2. Open end gear cover, remove lower rear cover and lower side cover. This will expose the motor and v-belts.
3. Loosen upper hex nut (A, Figure 28). Place scrap piece of wood under motor to act as lever. Lift motor up and block temporarily.
4. Remove belts. Install new belts onto pulleys.
5. Lift up on motor and remove temporary blocking.
6. Tension belts by loosening lower nut (B, Figure 28) and tightening upper nut (A, Figure 28) until light finger pressure causes approximately 3/4" deflection on each belt.
7. Install covers and connect lathe to the power source.

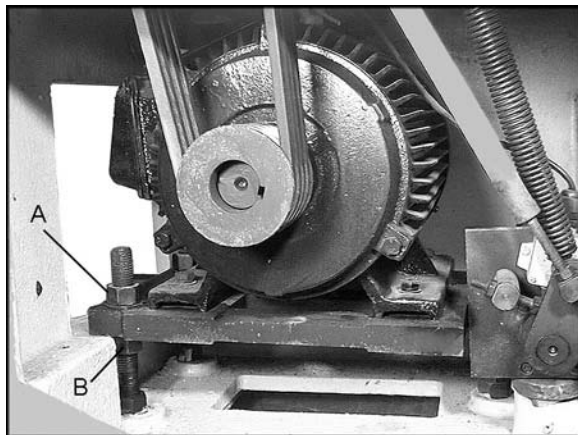

Figure 28 – Belt adjustment

14.7 Aligning tailstock to headstock

1. Fit a 12" ground steel bar between centers of the headstock and tailstock (Figure 29).
2. Fit a dial indicator to the top slide and traverse the center line of the bar.

If adjustment is needed, align the tailstock using the off-set screws (D, Figure 27) until the tailstock is aligned.

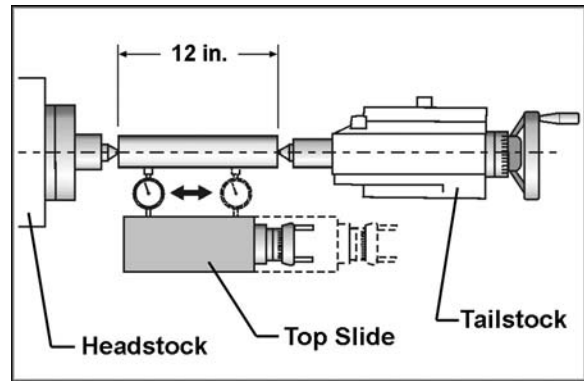

Figure 29 – Tailstock/Headstock alignment

14.8 Cross slide nut adjustment

The cross slide moves via a lead screw which drives a nut. This can be adjusted if backlash develops. Backlash is identified by turning the cross slide handwheel left and right – if there is a delay before any cross slide movement, the nut needs adjusting.

Tighten or loosen the two screws shown in Figure 30 until backlash is adjusted out.

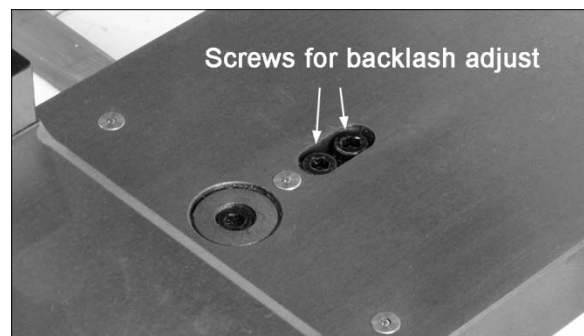

Figure 30 – Cross slide nut adjustment

14.9 Shear pin replacement

The lead screw and feed shaft are equipped with shear pins, which are designed to break in order to protect the drive system against overload. A broken shear pin must be replaced.

Knock out the broken pin; line up the holes and insert new pin.

14.10 Steady rest adjustment

Always lubricate the fingers with grease before using the steady rest. The point at which the fingers contact the workpiece require continuous lubrication to prevent premature wear.

To set the steady rest (see Figure 31):

1. Loosen hex nut (A) to slide steady rest along the ways.
2. Loosen knurled handle (B) until it can be pivoted out of the slot.
3. Loosen three lock knobs (C), and back off the fingers (D) using knurled handles (E).

4. Pivot the collar on its hinge and position steady rest around workpiece.
5. Firmly tighten hex nut (A).
6. Set the fingers snugly to work piece and secure by tightening locking knobs. *Fingers should be snug but not overly tight.*

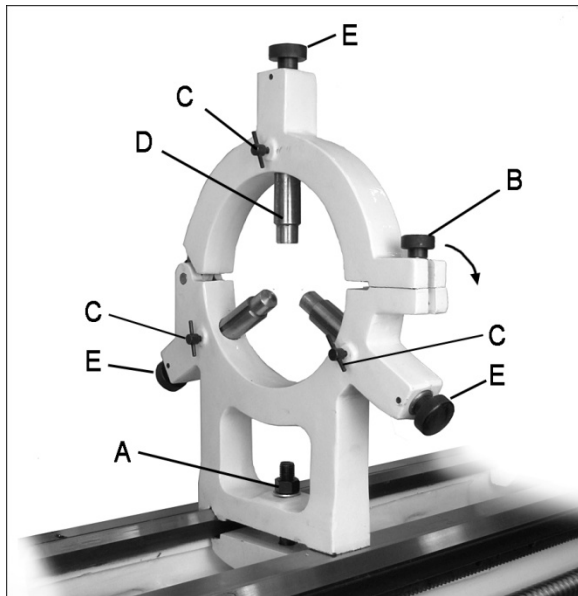

Figure 31 – Steady rest adjustment

14.11 Follow rest adjustment

The follow rest mounts to the saddle with two socket head cap bolts. The follow rest should be mounted so that locking knobs point away from chuck.

The sliding fingers are set similar to those on the steady rest – free of play, but not binding.

Always lubricate the fingers sufficiently with grease before operating.

14.12 Carriage stops

Adjust each stop (Figure 32) by loosening two set screws, and sliding it along the rod. Rotate the stop so that the raised area is upward to contact the carriage. Tighten both set screws securely.

Position the raised area downward when the stop is not being used.

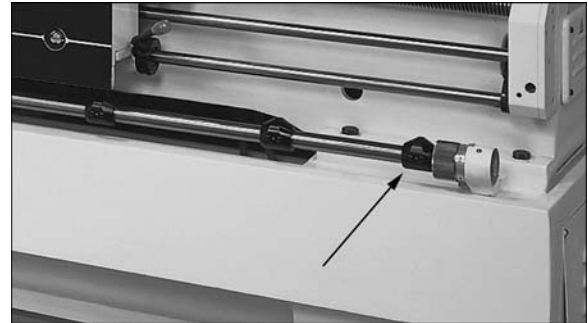

Figure 32

15.0 Lubrication schedule and general maintenance

Regularly scheduled maintenance is crucial to ensure a long service life for your machine. The schedule below shows general cleaning, lubrication points and coolant replacement information for the ZX Series Lathes. **Push stop button and power off before lubricating.** Follow local regulations for disposal of used coolant/lubricants. Minimize direct skin contact with lubricants and coolants, and wear eye protection when pouring coolant in case of splash.

Mobile DTE® Oil Heavy Medium is recommended for the SAE-20W machine oil.

If the brand of oil is ever changed, it is recommended that you flush and clean the reservoir first to prevent any compatibility issues.

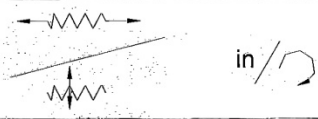



Table 1

Section	Element	Action	Lubricant	Frequency
8.3	Chuck	Grease jaws and scroll	#2 lithium tube grease	periodically
9.0		Fill at (1) ball oiler	SAE-20W machine oil	daily
8.3	Spindle/cam locks/ chuck body	light coat of oil	SAE-20W machine oil	periodically
	All exposed metal surfaces	light coat of oil	SAE-20W machine oil	frequently
9.0	Headstock	Drain and fill	SAE-20W machine oil	- after 30 days, - every 2 months
9.0	Gearbox	Drain and fill	SAE-20W machine oil	- after first 3 months, - every 6 months
9.0	Apron and Saddle	Drain and fill	SAE-20W machine oil	- after first 3 months, - then annually
9.0	Leadscrew; Feed Rod; Spindle Direction Control Axle	Fill at ball oilers	SAE-20W machine oil	daily (1 or 2 times per shift)
	Travel Setting Rod	Fill at (1) ball oiler	SAE-20W machine oil	as needed
9.0	Cross slide	Fill at (2) ball oilers	SAE-20W machine oil	daily
9.0	Compound rest	Fill at (2) ball oilers	SAE-20W machine oil	daily
9.0	Tool Post	Fill at (1) ball oiler	SAE-20W machine oil	daily
9.0	Tailstock	Fill at (1) ball oiler	SAE-20W machine oil	daily
9.0	Anti-dust felt on v-ways	Clean	kerosene	Inspect weekly
10.0	Coolant reservoir	(follow coolant manufacturer's directions)	Coolant of choice, approx. 4 gallons	(follow coolant manufacturer's directions)
14.10	Steady Rest	Lubricate finger shafts and contact points	Lead-based grease	before each use
14.11	Follow Rest	Lubricate finger shafts and contact points	Lead-based grease	before each use
14.6	V-belts	Inspect and tighten if needed		periodically

16.0 Reference tables

16.1 Inch Lead And Feed

Table 2

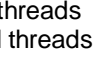
LEAD SCREW 4T. P. I CROSS SCREW 8T. P. I											
LEVER →		I	II	III	IV	V	I	II	III	IV	V
IN  T/1"	1G	72	36	18	9	4 1/2	0.015	0.031	0.062	0.124	0.248
	4G	60	30	15	7 1/2	3 3/4	0.006	0.012	0.025	0.050	0.099
	6G	54	27	13 1/2	6 3/4	3 3/8	0.007	0.015	0.029	0.059	0.118
	1E	48	24	12	6	3	0.008	0.016	0.032	0.065	0.130
	2E	46	23	11 1/2	5 3/4	2 7/8	0.015	0.031	0.062	0.124	0.248
	3E	44	22	11	5 1/2	2 3/4	0.006	0.012	0.025	0.050	0.099
	8G	42	21	10 1/2	5 1/4	2 5/8	0.004	0.008	0.016	0.032	0.065
	4E	40	20	10	5	2 1/2	0.016	0.033	0.066	0.132	0.263
	5E	38	19	9 1/2	4 3/4	2 3/8	0.006	0.013	0.026	0.053	0.105
DP  DP	6E	36	18	9	4 1/2	2 1/4	0.026	0.052	0.104	0.209	0.418
	7E	32	16	8	4	2	0.010	0.021	0.042	0.084	0.167
	8E	28	14	7	3 1/2	1 3/4	0.018	0.037	0.073	0.147	0.294
	9E	26	13	6 1/2	3 1/4	1 5/8	0.007	0.015	0.029	0.059	0.118
	1E	96	48	24	12	6	0.019	0.039	0.077	0.155	0.309
	2E	92	46	23	11 1/2	5 3/4	0.008	0.016	0.031	0.062	0.124
	3E	88	44	22	11	5 1/2	0.020	0.041	0.081	0.162	0.325
	4E	80	40	20	10	5	0.008	0.016	0.032	0.065	0.130
	5E	76	38	19	9 1/2	4 3/4	0.022	0.044	0.089	0.178	0.356
MM  MM	6E	72	36	18	9	4 1/2	0.009	0.018	0.036	0.071	0.142
	7E	64	32	16	8	4	0.026	0.052	0.104	0.209	0.418
	8E	56	28	14	7	3 1/2	0.010	0.021	0.042	0.084	0.167
	9E	52	26	13	6 1/2	3 1/4	0.028	0.056	0.112	0.224	0.449
	1E	96	48	24	12	6	0.011	0.022	0.045	0.090	0.180
	2E	92	46	23	11 1/2	5 3/4	0.023	0.046	0.093	0.186	0.371
	3E	88	44	22	11	5 1/2	0.009	0.018	0.037	0.074	0.148
	4E	80	40	20	10	5	0.025	0.050	0.101	0.201	0.402
	5E	76	38	19	9 1/2	4 3/4	0.010	0.020	0.040	0.080	0.161
MP  MP	6E	72	36	18	9	4 1/2	0.026	0.052	0.104	0.209	0.418
	7E	64	32	16	8	4	0.010	0.021	0.042	0.084	0.167
	8E	56	28	14	7	3 1/2	0.029	0.058	0.116	0.232	0.464
	9E	52	26	13	6 1/2	3 1/4	0.012	0.023	0.046	0.093	0.186
	1E	96	48	24	12	6	0.030	0.060	0.120	0.240	0.480
	2E	92	46	23	11 1/2	5 3/4	0.012	0.024	0.048	0.096	0.192
	3E	88	44	22	11	5 1/2	0.032	0.064	0.128	0.255	0.511
	4E	80	40	20	10	5	0.013	0.026	0.051	0.102	0.204
	5E	76	38	19	9 1/2	4 3/4	0.036	0.072	0.143	0.286	0.573
MP  MP	6E	72	36	18	9	4 1/2	0.014	0.029	0.057	0.114	0.229
	7E	64	32	16	8	4	0.041	0.081	0.162	0.325	0.650
	8E	56	28	14	7	3 1/2	0.016	0.032	0.065	0.130	0.260
	9E	52	26	13	6 1/2	3 1/4	0.044	0.087	0.174	0.348	0.696
	1E	96	48	24	12	6	0.018	0.035	0.070	0.139	0.278
	2E	92	46	23	11 1/2	5 3/4	0.021	0.043	0.085	0.170	0.340
	3E	88	44	22	11	5 1/2	0.008	0.017	0.034	0.068	0.136
	4E	80	40	20	10	5	0.025	0.051	0.102	0.205	0.410
	5E	76	38	19	9 1/2	4 3/4	0.010	0.020	0.041	0.082	0.164

- t = metric threads
- n = inch threads
- m = modular threads
- DP = diametral threads

This page intentionally left blank.

This page intentionally left blank.



427 New Sanford Road
LaVergne, Tennessee 37086
Phone: 800-274-6848
www.jettools.com



Model No.:	Stock No.:
Serial No.:	
Purchased From:	
Date Purchased:	Date Installed:

Parts List and Electrical Diagrams ZX-Series Large Bore Lathes

Models GH-1440ZX
GH-1640ZX/1660ZX
GH-1860ZX/1880ZX
GH-2280ZX

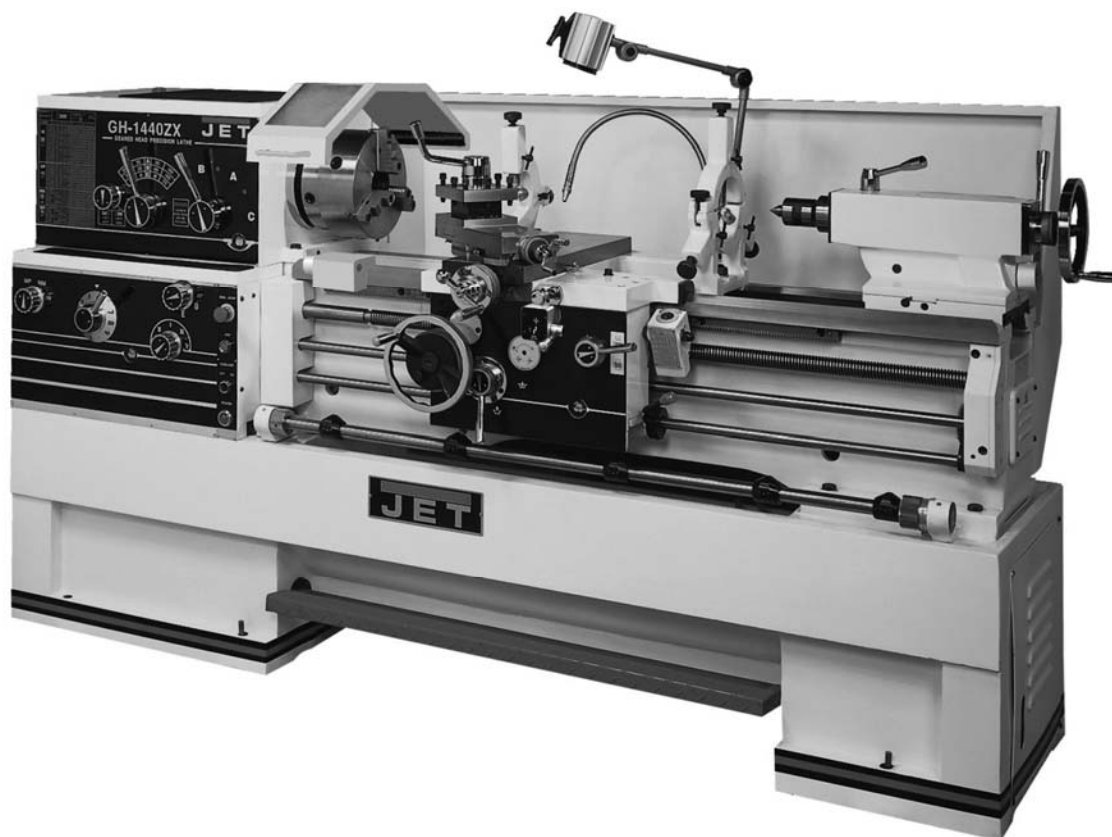

Model GH-1440ZX shown

*** For ZX-Series Lathes Operating Instructions, see document M-321910**

JET

427 New Sanford Road
LaVergne, Tennessee 37086
Ph.: 800-274-6848
www.jettools.com

Part No. M-321910-1
Revision I 11/2014
Copyright © 2014 JET

1.0 Table of contents

Section	Page
1.0 Table of contents.....	2
2.0 Stand Assembly – Exploded View	3
2.1 Stand Assembly – Parts List	4
3.0 Brake Assembly – Exploded View	6
3.1 Brake Assembly – Parts List	7
4.0 Bed Assembly – Exploded View	8
4.1 Bed Assembly – Parts List	9
5.0 Headstock Assembly I – Exploded View	11
5.1 Headstock Assembly I – Parts List.....	12
6.0 Headstock Assembly II – Exploded View	14
6.1 Headstock Assembly II – Parts List.....	15
7.0 Headstock Assembly III – Exploded View	17
7.1 Headstock Assembly III – Parts List.....	18
8.0 Headstock Assembly IV – Exploded View	19
8.1 Headstock Assembly IV – Parts List	20
9.0 Change Gear Box Assembly I – Exploded View	21
9.1 Change Gear Box Assembly I – Parts List	22
10.0 Change Gear Box Assembly II – Exploded View	23
10.1 Change Gear Box Assembly II – Parts List.....	24
11.0 Quick Change Gear Box I – Exploded View	25
11.1 Quick Change Gear Box I – Parts List	26
12.0 Quick Change Gear Box II – Exploded View	28
12.1 Quick Change Gear Box II – Parts List	29
13.0 Quick Change Gear Box III – Exploded View	30
13.1 Quick Change Gear Box III – Parts List	31
14.0 Apron Assembly I – Exploded View	32
14.1 Apron Assembly I – Parts List	33
15.0 Apron Assembly II – Exploded View	35
15.1 Apron Assembly II – Parts List	36
16.0 Apron Assembly III – Exploded View	38
16.1 Apron Assembly III – Parts List	39
17.0 Carriage Assembly – Exploded View	40
17.1 Carriage Assembly – Parts List	41
18.0 Micro Carriage Stop – Exploded View	43
18.1 Micro Carriage Stop – Parts List	43
19.0 Carriage Stop Assembly – Exploded View.....	44
19.1 Carriage Stop Assembly – Parts List	45
20.0 Four Way Tool Post – Exploded View.....	46
20.1 Four Way Tool Post – Parts List	47
21.0 Tailstock Assembly I – Exploded View.....	48
21.1 Tailstock Assembly I – Parts List	49
22.0 Tailstock Assembly II – Exploded View.....	50
22.1 Tailstock Assembly II – Parts List	51
23.0 Steady Rest Assembly – Exploded View	52
23.1 Steady Rest Assembly – Parts List	53
24.0 Follow Rest Assembly – Exploded View	54
24.1 Follow Rest Assembly – Parts List	55
25.0 Coolant & Work Light Assembly – Exploded View	56
25.1 Coolant & Work Light Assembly – Parts List.....	57
26.0 Chuck Guard Assembly – Exploded View.....	58
26.1 Chuck Guard Assembly – Parts List	58
27.0 Other Parts	59
28.0 Electrical Cabinet – Parts List	60
29.0 Wiring Diagram	61
30.0 Rotary Switch Diagram	62

2.0 Stand Assembly – Exploded View

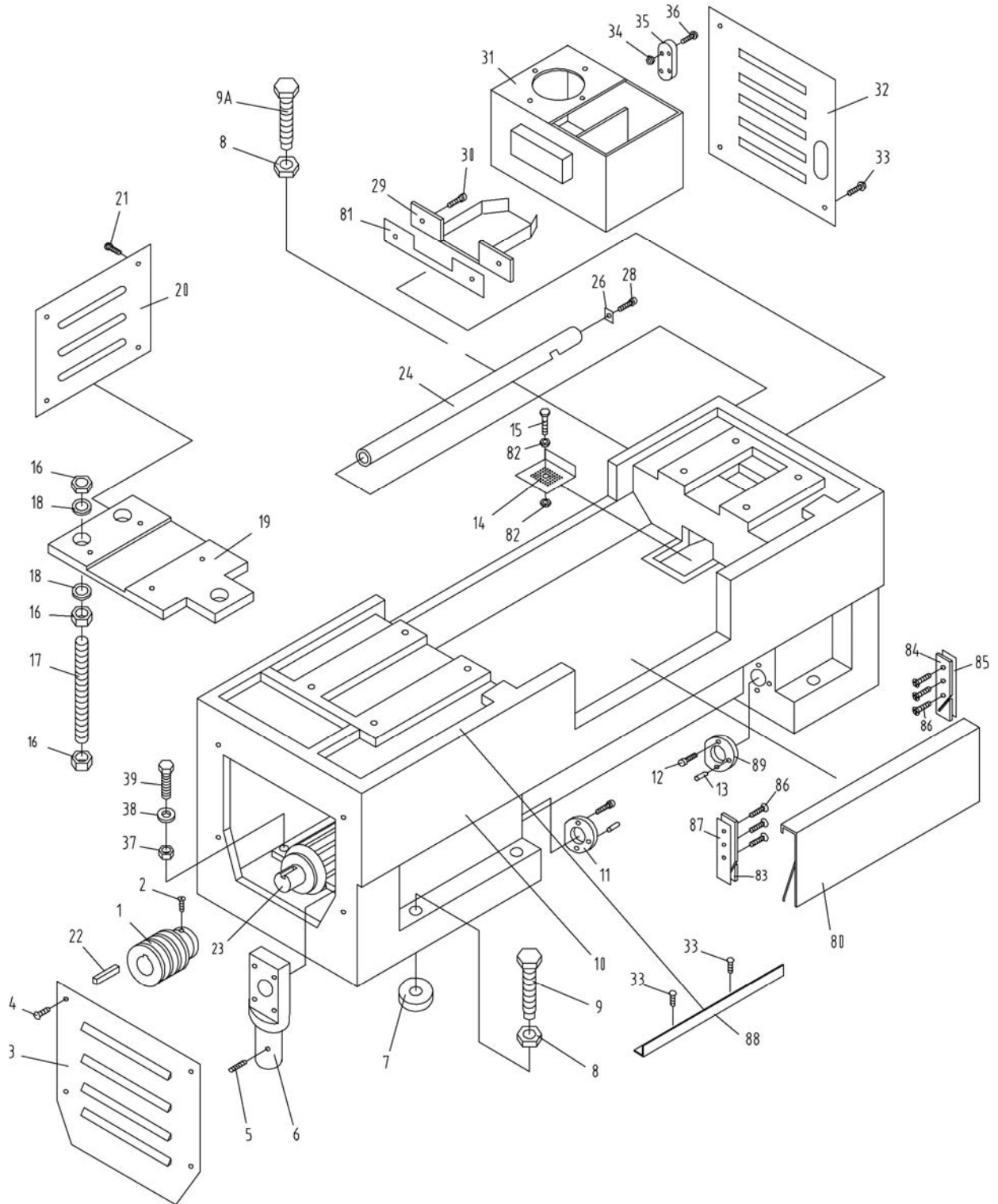

2.1 Stand Assembly – Parts List

Index No	Part No	Description	Size	Qty
1	ZX-01101A	Pulley		1
	GH2280ZX-01101	Pulley (for 2280ZX)		1
2	ZX-S2	Cylindrical End Set Screw	M8x16	1
3	ZX-01734	Cover		1
	ML-2080-01701	Cover (for 2280ZX)		1
4	ZX-S4	Cross Head Screw	M6x14	4
5	ZX-S2	Cylindrical End Set Screw	M8x16	1
6	ZX-01701	Pedal Rod Support		1
	ML-2080-01703	Pedal Rod Support (for 2280ZX)		1
7	ZX-01715	Leveling Pad		6
8	TS-1540231	Hex Nut	M24-2	6
9	ZX-01712	Hex Cap Bolt		3
9A	ZX-01713	Hex Cap Bolt		3
10	ZX-01102A	Bed Stand (for 40" models, serial # 010611ZX349 and lower)		1
	ZX-01102AN	New Bed Stand (for 40" models, serial # 010618ZX350 and higher)		1
	ZX-01102B	Bed Stand (for 60" models, serial # 010611ZX349 and lower)		1
	ZX-01102BN	New Bed Stand (for 60" models, serial # 010618ZX350 and higher)		1
	ZX-01102C	Bed Stand (for 1880ZX, serial # 010611ZX349 and lower)		1
	ZX-01102CN	New Bed Stand (for 1880ZX, serial # 010618ZX350 and higher)		1
	GH2280ZX-01102	Bed Stand (for 2280ZX)		1
11	ZX-01703	Fixed Support		2
12	TS-150341	Socket Head Cap Screw	M6x14	4
13	ZX-S13	Taper Pin	5x20	2
14	ZX-01705	Water Leaking Chip Guard		1
15	ZX-S15A	Cross Head Screw	M5x20	4
16	TS-1540121	Hex Nut	M20	9
17	ZX-01702	Bolt		3
	ML-2080-01704	Bolt (for 2280ZX)		3
18	TS-1550111	Flat Washer	M20	6
19	ZX-01122A	Motor Mounting Plate (for 14" models)		1
	ZX-01122B	Motor Mounting Plate (for 16"/18" models)		1
	ML-2080-01122	Motor Mounting Plate (for 22" model)		1
20	ZX-01726	Cover		1
	GH2280ZX-01701	Cover		1
21	ZX-S4	Cross Head Screw	M6x14	4
22	ZX-S22	Key	10x8x70	1
23	ZX-S23BC	Main Motor (for 22" model)	10 HP, 6P, 3Ph	1
	ZX-S23A	Main Motor (for 14" models)	7.5HP, 4P, 3Ph	1
	ZX-S23B	Main Motor (for 16"/18" models)	7.5HP, 6P, 3Ph	1
24	ZX-017609A	Wire Conduit (for 1440/1640/1840ZX)		1
	ZX-017609B	Wire Conduit (for 1460/1660/1860ZX)		1
	ZX-017609C	Wire Conduit (for 1880/2280ZX)		1
26	ZX-S26	Locking Plate		1
28	ZX-S15	Cross Head Screw	M4x6	1
29	ZX-01711	Water Reception Plate		1
30	ZX-S4	Cross Head Screw	M6x14	2
31	ZX-01510	Coolant Tank		1
32	ZX-01714	Cover		1
	ML-2080-01702	Cover (for 2280ZX)		1
33	ZX-S4	Cross Head Screw	M6x14	4
34	ZX-S34	Nut	M3	4
35	ZX-S35	Coolant Indicator		1
36	ZX-S36	Cross Head Screw	M3x20	4
37	TS-1540072	Hex Nut	M10	4
38	TS-1550071	Flat Washer	M10	4
39	TS-1491041	Hex Cap Bolt	M10x30	4
80	ZX-01716A	Stand Front Cover (for 1440/1640/1840ZX)		1
	ZX-01716B	Stand Front Cover (for 1460/1660/1860ZX)		1
	ZX-01716C	Stand Front Cover (for 1880/2280ZX)		1
81	ZX-01501	Gasket		1

Index No	Part No	Description	Size	Qty
82	ZX-S82	Hex Nut	M5	2
83	ZX-01740	Left Tray		1
84	ZX-01741	Right Tray		1
85	ZX-01511	Gasket		2
86	ZX-S86	Cross Head Screw	M5x16	6
87	ZX-01512	Gasket		1
88	ZX-05753	Extending Plate		1
89	ZX-01703A	Fixed Support (serial # 070916ZX1738 and higher)		1
	JX21004	Terminal Board (not shown)		1
	18301	Junction Box (not shown)		1
	D97-4	Plastic Fitting (not shown)		1

3.0 Brake Assembly – Exploded View

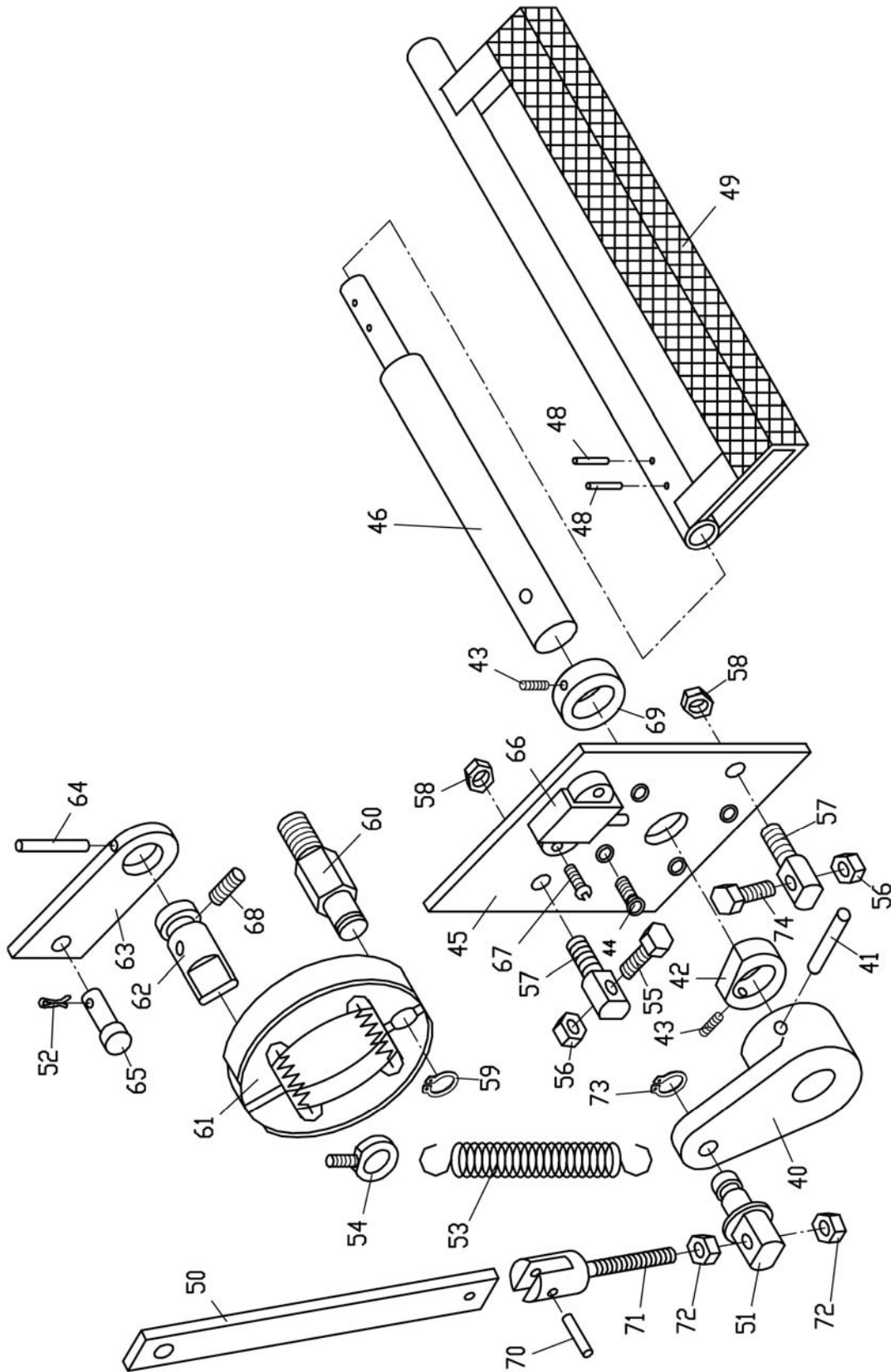

3.1 Brake Assembly – Parts List

Index No	Part No	Description	Size	Qty
40	ZX-22101	Fork		1
41	ZX-S41	Spring Pin	5x40	1
42	ZX-22703	Butt Nail Support		1
43	TS-1524021	Socket Set Screw	M8x10	1
44	ZX-S44	Cross Head Screw	M5x20	4
45	ZX-22714	Positioning Plate		1
46	ZX-22704A	Driving Shaft-Longer		1
48	ZX-S48	Spring Pin	5x30	3
49	ZX-22712A	Pedal (for 1440/1640/1840ZX)(serial # 070820ZX1737 and lower)		1
	ZX-22712AE	Pedal (for 1440/1640/1840ZX)(serial # 070916ZX1738 and higher)		1
	ZX-22712B	Pedal (for 1460/1660/1860ZX)(serial # 070820ZX1737 and lower)		1
	ZX-22712BE	Pedal (for 1460/1660/1860ZX)(serial # 070916ZX1738 and higher)		1
	ZX-22712C	Pedal (for 1880/2280ZX)(serial # 070820ZX1737 and lower)		1
	ZX-22712CE	Pedal (for 1880/2280ZX)(serial # 070916ZX1738 and higher)		1
50	ZX-22710A	Draw Bar (for 14" models)		1
	ZX-22710B	Draw Bar (for 16" models)		1
	ZX-22710C	Draw Bar (for 18" models)		1
	GH2280ZX-22710	Draw Bar (for 22" model)		1
51	ZX-22706	Connecting Shaft		1
52	ZX-S52	Split Pin	2x20	2
53	ZX-S53	Tensile Spring	3.5x26x190	1
54	ZX-S54	Eyebolt	M8	1
55	TS-1490091	Hex Cap Bolt	M8x50	1
56	TS-1540061	Hex Nut	M8	1
57	ZX-22707A	Butt Rod Support		1
58	TS-1540072	Hex Nut	M10	1
59	ZX-S59	C-Clip	8	1
60	ZX-22701	Positioning Shaft		1
61	ZX-S61	Brake Shoe		1
62	ZX-22702	Brake Shaft		1
63	ZX-22708	Connecting Plate		1
64	ZX-S64	Elastic Pin	5x25	1
65	ZX-22709	Connecting Shaft		1
66	ZX-S66	Stroke Switch		1
67	ZX-S67	Screw	M4x25	2
68	ZX-S68	Cylindrical End Set Screw	M5x10	1
69	ZX-22711	Butt Nail Support		1
70	ZX-S70	Pin	5n6x20	1
71	ZX-22715	Adjust Bolt		1
72	TS-1540061	Hex Nut	M8	1
73	ZX-S73	C-Clip	12	2
74	TS-149006	Hex Cap Screw	M8x35	1

4.0 Bed Assembly – Exploded View

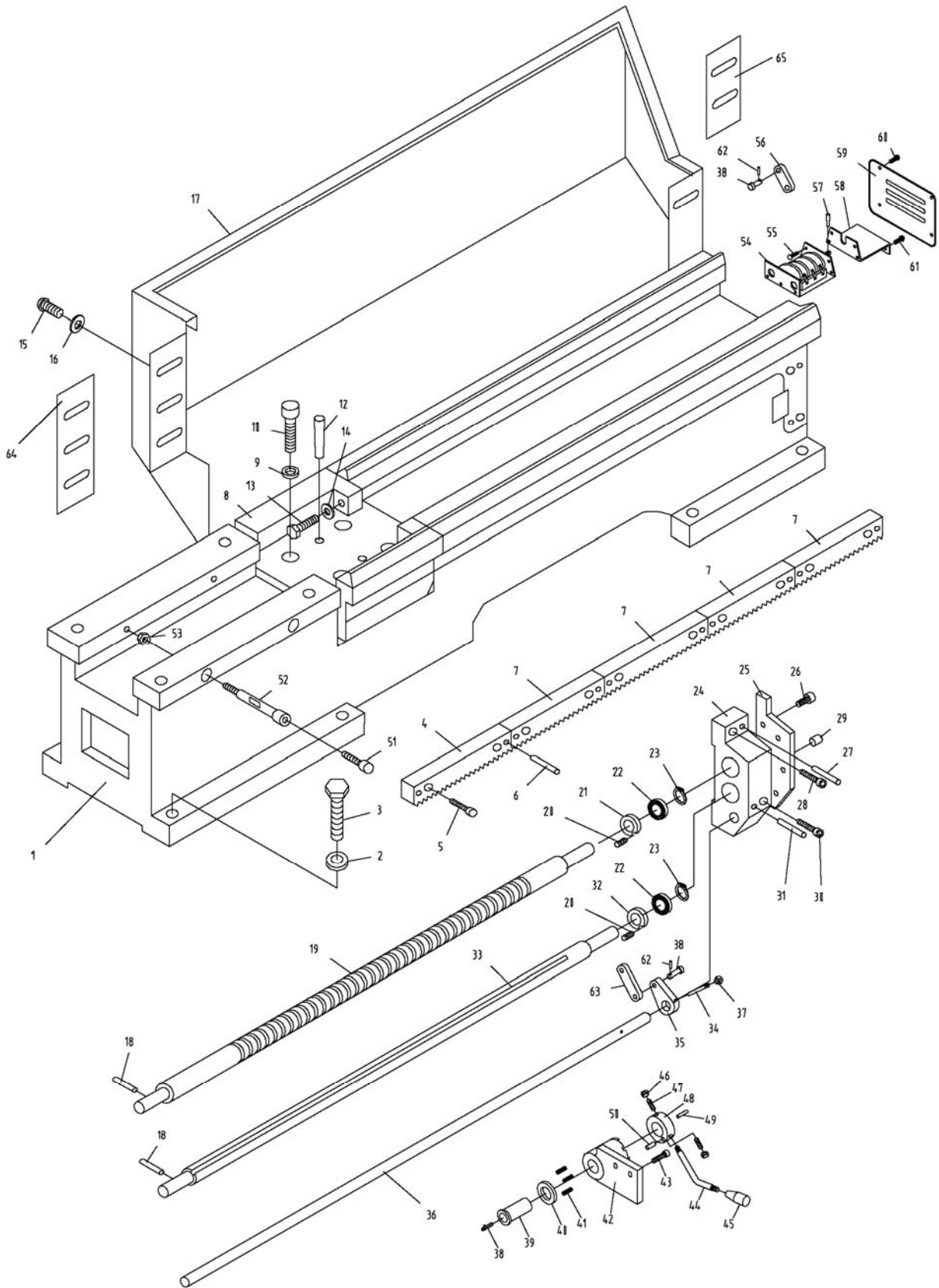

4.1 Bed Assembly – Parts List

Index No	Part No	Description	Size	Qty
1	ZX-01104A	Bed (for 1440/1640/1840ZX)		1
	ZX-01104B	Bed (for 1460/1660/1860ZX)		1
	ZX-01104C	Bed (for 1880/2280ZX)		1
2	TS-1550101	Flat Washer	M16	8
3	ZX-B3	Hex Cap Bolt	M16x50	8
4	ZX-01706	Rack		1
5	TS-1505051	Hex Socket Cap Screw (for 1440/1640/1840ZX)	M10x35	10
		Hex Socket Cap Screw (for 1460/1660/1860ZX)	M10x35	14
		Hex Socket Cap Screw (for 1880/2280ZX)	M10x35	18
6	ZX-B6	Taper Pin (for 1440/1640/1840ZX)	8x50	10
		Taper Pin (for 1460/1660/1860ZX)	8x50	14
		Taper Pin (for 1880/2280ZX)	8x50	18
7	ZX-01706A	Rack (for 1440/1640/1840ZX)		4
		Rack (for 1460/1660/1860ZX)		6
		Rack (for 1880/2280ZX)		8
8	ZX-01112	Gap Bridge		1
9	TS-1551081	Lock Washer	M12	4
10	TS-1506091	Hex Socket Cap Screw	M12x55	4
12	ZX-B12	Thread Taper Pin	12x70	2
13	TS-1491101	Hex Cap Bolt	M10x60	2
14	TS-1550071	Washer	M10	2
15	TS-1503021	Hex Socket Cap Screw	M6x10	6
16	TS-1550041	Washer	M6	6
17	ZX-01741A	Splash Guard (for 1440ZX)		1
	ZX-01741B	Splash Guard (for 1460ZX)		1
	ZX-01741C	Splash Guard (for 1640ZX)		1
	ZX-01741D	Splash Guard (for 1660ZX)		1
	ZX-01741E	Splash Guard (for 1840ZX)		1
	ZX-01741F	Splash Guard (for 1860ZX)		1
	ZX-01741G	Splash Guard (for 1880ZX)		1
	GH2280ZX-12701	Splash Guard (for 2280ZX)		1
18	ZX-B18	Shear Pin	5x35	2
19	ZX-01708A	Lead Screw (for 40" models, serial # 010611ZX349 and lower)		1
	ZX-01708AN	New Lead Screw (for 40" models, serial # 010618ZX350 and higher)		1
	ZX-01708B	Lead Screw (for 60" models, serial # 010611ZX349 and lower)		1
	ZX-01708BN	New Lead Screw (for 60" models, serial # 010618ZX350 and higher)		1
	ZX-01708C	Lead Screw (for 80" models, serial #010611ZX349 and lower)		1
	ZX-01708CN	New Lead Screw (for 80" models, serial #010618ZX350 and higher)		1
20	ZX-B20	Flat End Set Screw	M6x10	2
21	ZX-01109	Sleeve (serial # 010611ZX349 and lower)		1
	ZX-01109N	New Sleeve (serial # 010618ZX350 and higher)		1
22	ZX-1204	Double Row Spherical Ball Bearing	20x47x14	2
23	ZX-B23	C-Clip	20	2
24	ZX-01110	Bracket (serial # 010611ZX349 and lower)		1
	ZX-01110N	New Bracket (serial # 010618ZX350 and higher)		1
25	ZX-01111	Cover		1
26	TS-1503041	Hex Socket Cap Screw	M6x16	4
27	ZX-B27	Taper Pin	6x60	1
28	TS-1505081	Socket Cap Screw	M10x50	1
29	ZX-B29	Oil Cup	10	2
30	GH2280ZX-1230	Socket Cap Screw	M10x100	1
31	ZX-B31	Taper Pin	6x100	1
32	ZX-01108	Sleeve (serial # 010611ZX349 and lower)		1
	ZX-01108N	New Sleeve (serial # 010618ZX350 and higher)		1
33	ZX-01709A	Feed Rod (for 40" models, serial # 010611ZX349 and lower)		1
	ZX-01709AN	New Feed Rod (for 40" models, serial # 010618ZX350 and higher)		1
	ZX-01709B	Feed Rod (for 60" models, serial # 010611ZX349 and lower)		1
	ZX-01709BN	New Feed Rod (for 60" models, serial # 010618ZX350 and higher)		1
	ZX-01709C	Feed Rod (for 80" models, serial # 010611ZX349 and lower)		1
	ZX-01709CN	New Feed Rod (for 80" models, serial # 010618ZX350 and higher)		1

Index No	Part No	Description	Size	Qty
34	ZX-B34	Taper Pin	5x30	1
35	ZX-01107	Poking Block		1
36	ZX-01707A	Control Rod (for 1440/1640/1840ZX)		1
	ZX-01707B	Control Rod (for 1460/1660/1860ZX)		1
	ZX-01707C	Control Rod (for 1880/2280ZX)		1
37	TS-1540031	Nut	M5	1
38	ZX-06720	Small Shaft		2
39	ZX-06001C-3	Sleeve		1
40	ZX-06001C-2	Spacer		1
41	ZX-B41	Spring	1x75x25	3
42	ZX-06001C-1	Bracket		1
43	TS-1504031	Hex Socket Cap Screw	M8x16	2
44	ZX-B44	Lever		1
45	ZX-06001C-4	Long Lever Sleeve		1
46	ZX-B46	Hex Nut	M8	2
47	ZX-B47	Set Screw	M8x28	2
48	ZX-06001C-5	Direction Change Ring		1
49	ZX-B49	Pin	8n6x20	1
50	ZX-B50	Taper Pin	3x20	1
51	TS-1505081	Socket Cap Screw	M10x50	2
52	ZX-05741	Threaded Tube		2
53	TS-1540081	Hex Nut	M12	2
54	ZX-B54	Drum Switch		1
55	ZX-S27	Cross Head Screw	M5x8	5
56	ZX-01718	Rocker		1
57	ZX-B57	Pin	3x16	1
58	ZX-01716	Bracket		1
59	ZX-01715C	Cover		1
60	ZX-B60	Cross Recessed Pan Head Screw	M6x18	4
61	TS-1482031	Hex Cap Bolt	M6x16	2
62	ZX-B62	Pin	2x15	2
63	ZX-01719	Rocker		1
64	ZX-LRG14	Rubber Washer (for 14" models)		1
	ZX-LRG16	Rubber Washer (for 16" models)		1
	ZX-LRG18	Rubber Washer (for 18" models)		1
	ZX-LRG22	Rubber Washer (for 22" models)		1
65	ZX-RRG	Rubber Washer		1

5.0 Headstock Assembly I – Exploded View

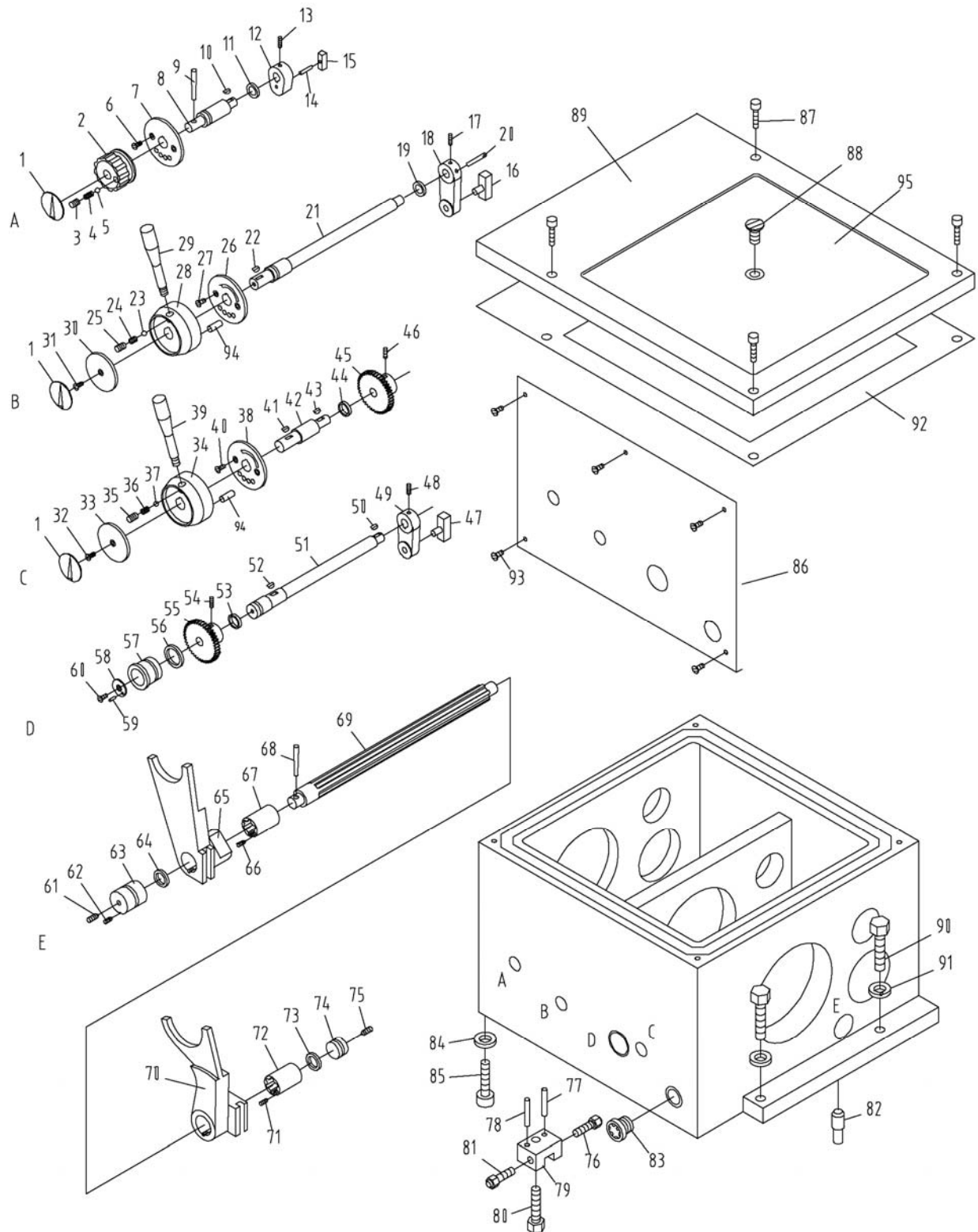

5.1 Headstock Assembly I – Parts List

Index No	Part No	Description	Size	Qty
1	ZX-02306	Round Sign Plate		3
2	ZX-02122	Positioning Handle		1
3	ZX-H3	Flat End Set Screw	M10x12	1
4	ZX-H4	Spring	YI-1x8x25	1
5	ZX-H5	Steel Ball	8	1
6	ZX-H6	Countersunk Head Screw	M5x12	2
7	ZX-02743	Positioning Disc		1
8	ZX-02738	Shaft		1
9	ZX-H9	Taper Pin	5x55	1
10	ZX-H10	Woodruff Key	4x16	1
11	ZX-H11	Ring Seal	25x2.4	1
12	ZX-02116	Crank		1
13	TS-1523051	Set Screw	M6x16	1
14	ZX-H14	Pin	5n6x28	1
15	ZX-02302	Poking Block		1
16	ZX-02738C	Pin Block		1
17	TS-1523051	Set Screw	M6x16	1
18	ZX-02114	Crank		1
19	ZX-H11	Ring Seal	25x2.4	1
20	ZX-H20	Pin	5x30	1
21	ZX-02734	Shaft		1
22	ZX-H10	Woodruff Key	4x16	1
23	ZX-H5	Steel Ball	8	1
24	ZX-H4	Spring	YI-1x8x25	1
25	ZX-H3	Flat End Set Screw	M10x12	1
26	ZX-02733	Left Positioning Disc		1
27	ZX-H6	Countersunk Head Screw	M5x12	2
28	ZX-02113	Left Lever Support		1
29	ZX-02741	Handle		1
30	ZX-02732	Cover		1
31	ZX-H6	Countersunk Head Screw	M5x12	1
32	ZX-H6	Countersunk Head Screw	M5x12	1
33	ZX-02732	Cover		1
34	ZX-02119	Right Lever Support		1
35	ZX-H3	Flat End Set Screw	M10x12	1
36	ZX-H4	Spring	YI-1x8x25	1
37	ZX-H5	Steel Ball	8	1
38	ZX-02728	Right Positioning Disc		1
39	ZX-02741	Handle		1
40	ZX-H6	Countersunk Head Screw	M5x12	2
41	ZX-H10	Woodruff Key	4x16	1
42	ZX-02727	Shaft		1
43	ZX-H10	Half Circle Key	4x16	1
44	ZX-H11	Ring Seal	25x2.4	1
45	ZX-02730	Gear	1.5m36T	1
46	TS-1523051	Set Screw	M6x16	1
47	ZX-02738C	Pin Block		1
48	TS-1523051	Set Screw	M6x16	1
49	ZX-02111	Crank		1
50	ZX-H10	Woodruff Key	4x16	1
51	ZX-02731/1	Control Shaft		1
52	ZX-H10	Woodruff Key	4x16	1
53	ZX-H11	Ring Seal	25x2.4	1
54	ZX-H54	Taper End Set Screw	M6x16	1
55	ZX-02732/2	Gear	1.5m36T	1
56	ZX-H56	Ring Seal	40x3.1	1
57	ZX-02110	Bushing		1
58	ZX-02729	Cover		1
59	ZX-H59	Pin	3n6x10	1
60	ZX-H6	Countersunk Head Screw	M5x12	1

Index No	Part No	Description	Size	Qty
61	ZX-H61	Countersunk Head Screw	M8x12	1
62	ZX-H62	Flat End Set Screw	M8x12	1
63	ZX-02115C	Bearing Support		1
64	ZX-H64	Ring Seal	40x3.1	1
65	ZX-02115	Left Fork		1
66	ZX-H66	Flat End Set Screw	M6x10	1
67	ZX-02120A/2	Bushing		1
68	ZX-H68	Taper Pin	6x35	1
69	ZX-02736	Control Shaft		1
70	ZX-02112	Right Fork		1
71	ZX-H66	Flat End Set Screw	M6x10	1
72	ZX-02120A/2	Bushing		1
73	ZX-H73	Ring Seal	30x3.1	1
74	ZX-02735	Blocking Piece		1
75	ZX-H61	Countersunk Head Screw	M8x12	1
76	ZX-02744	Adjusting Screw		1
77	ZX-H77	Taper Pin	8x40	1
78	ZX-H77	Taper Pin	8x40	1
79	ZX-92124	Adjusting Block		1
80	ZX-H80	Hex Cap Bolt	M12x50	1
81	ZX-02744	Adjusting Screw		1
82	ZX-02736C	Positioning Pin		1
83	ZX-H83	Oil Sight Glass		1
84	ZX-H84	Washer	A16	2
85	ZX-H85	Hex Socket Cap Screw	M16x50	2
86	ZX-02301A	Label (for 1440ZX) (serial #110915ZX2363 and lower)		1
	ZX-02301AJ	Label (for 1440ZX) (serial #110930ZX2364 and higher)		1
	ZX-02301B	Label (for 1460ZX) (serial #110915ZX2363 and lower)		1
	ZX-02301BJ	Label (for 1460ZX) (serial #110930ZX2364 and higher)		1
	ZX-02301C	Label (for 1640ZX) (serial #110915ZX2363 and lower)		1
	ZX-02301CJ	Label (for 1640ZX) (serial #110930ZX2364 and higher)		1
	ZX-02301D	Label (for 1660ZX) (serial #110915ZX2363 and lower)		1
	ZX-02301DJ	Label (for 1660ZX) (serial #110930ZX2364 and higher)		1
	ZX-02301E	Label (for 1840ZX) (serial #110915ZX2363 and lower)		1
	ZX-02301EJ	Label (for 1840ZX) (serial #110930ZX2364 and higher)		1
	ZX-02301F	Label (for 1860ZX) (serial #110915ZX2363 and lower)		1
	ZX-02301FJ	Label (for 1860ZX) (serial #110930ZX2364 and higher)		1
	ZX-02301G	Label (for 1880ZX) (serial #110915ZX2363 and lower)		1
	ZX-02301GJ	Label (for 1880ZX) (serial #110930ZX2364 and higher)		1
	GH2280ZX-02301	Label (for 2280ZX) (serial #110915ZX2363 and lower)		1
	GH2280ZX-02301J	Label (for 2280ZX) (serial #110930ZX2364 and higher)		1
87	TS-1504071	Hex Socket Cap Screw	M8x35	4
88	ZX-H88	Countersunk Head Screw	M16x25	1
89	ZX-02117	Top Cover		1
90	ZX-H90	Hex Cap Bolt		2
91	ZX-H91	Washer	A16	2
92	ZX-02505	Paper Gasket		1
93	TS-1531012	Slotted Pan Head Screw	M3x6	7
94	ZX-H94N	Pin	4n6x15	2
95	ZX-H95	Rubber Mat		1

6.0 Headstock Assembly II – Exploded View

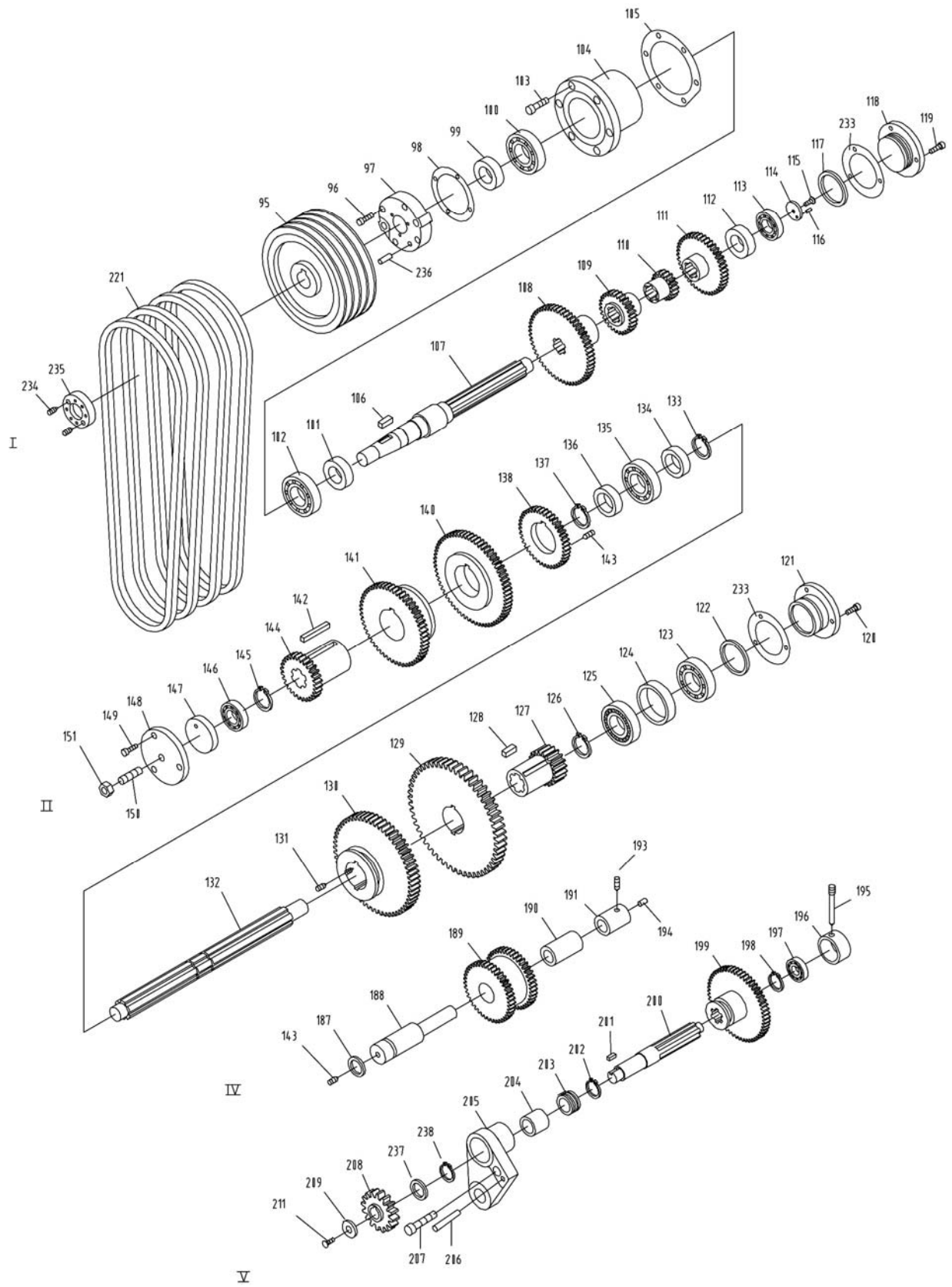

6.1 Headstock Assembly II – Parts List

Index No	Part No	Description	Size	Qty
95	ZX-02107	Pulley		1
96	TS-1503061	Socket Cap Screw	M6x25	4
97	ZX-02106	Bearing Cover		1
98	ZX-02506	Gasket		1
99	ZX-H99	Ring Seal	32x52	1
100	BB-6207/P5	Ball Bearing	35x72x17	1
101	ZX-H102	Sleeve	30x10	1
102	BB-6207/P5	Ball Bearing	35x72x17	1
103	TS-1504051	Socket Cap Screw	M8x25	6
104	ZX-02105	Bearing Support		1
105	ZX-02502	Gasket		1
106	ZX-H106	Flat Key	10x8x35	1
107	ZX-02709	Shaft		1
108	ZX-02754X	Gear (for 14" models)	2.5m52T	1
	ZX-02754X/6P	Gear (for 16"/18"/22" models)	2.5m61T	1
109	ZX-02753X	Gear (for 14" models)	2.5m28T	1
	ZX-02753X/6P	Gear (for 16"/18"/22" models)	2.5m32T	1
110	ZX-02752X	Gear	2.5m18T	1
111	ZX-02751X	Gear (for 14" models)	2.5m41T	1
	ZX-02751X/6P	Gear (for 16"/18"/22" models)	2.5m47T	1
112	ZX-H112	Sleeve		1
113	BB6305/P5	Ball Bearing	25x62x17	1
114	ZX-H114	Shaft End Lock Ring	32	1
115	ZX-H115	Countersunk Head Screw	M6x20	1
116	ZX-H59	Pin	3n6x10	1
117	ZX-H117	Ring Seal	60x3.1	1
118	ZX-02104	Blocking Flange		1
119	TS-1503041	Socket Cap Screw	M6x15	3
120	TS-1503041	Socket Cap Screw	M6x15	3
121	ZX-02103	Blocking Flange		1
122	ZX-H117	Ring Seal	60x3.1	1
123	BB-6305/P5	Ball Bearing	25x62x17	1
124	ZX-H124	Sleeve	62x6	1
125	BB-6305/P5	Ball Bearing	25x62x17	1
126	ZX-H126	Circle Clip For Shaft	35	1
127	ZX-02705	Gear	3m19T	1
128	ZX-H128	Flat Key	8x7x50	2
129	ZX-02706	Gear	3m67T	1
130	ZX-02707	Gear	3m59T	1
131	ZX-H62	Flat End Set Screw	M8x12	1
132	ZX-02708	Shaft		1
133	ZX-H133	C-Clip	35	1
134	ZX-H134	Sleeve	35x8	1
135	BB-6007/P5	Ball Bearing	35x62x14	1
136	ZX-H134	Sleeve	35x8	1
137	ZX-H133	C-Clip	35	1
138	ZX-02756	Gear (for 14" models)	2.5m42T	1
	ZX-02756/6P	Gear (for 16"/18"/22" models)	2.5m36T	1
139	ZX-H139	Pin	8n6x25	1
140	ZX-02757	Gear (for 14" models)	2.5m65T	1
	ZX-02757/6P	Gear (for 16"/18"/22" models)	2.5m65T	1
141	ZX-02758	Gear (for 14" models)	2.5m55T	1
	ZX-02758/6P	Gear (for 16"/18"/22" models)	2.5m51T	1
142	ZX-H142	Flat Key	10x6x60	2
143	ZX-H143	Flat Head Set Screw	M8x12	2
144	ZX-02755X	Gear (for 14" models)	2.5m31T	1
	ZX-02755X/6P	Gear (for 16"/18"/22" models)	2.5m22T	1
145	ZX-H133	C-Clip	35	1
146	BB-6305	Ball Bearing	25x62x17	1
147	ZX-H147	Pushing Disc	62	1

Index No	Part No	Description	Size	Qty
148	ZX-02109C	Cover		1
149	TS-1503041	Socket Cap Screw	M6x15	3
150	ZX-H150	Set Screw	M12x65	1
151	ZX-H151	Hex Nut	M12	1
187	ZX-H187	Ring Seal	35x3.1	1
188	ZX-02714	Shaft		1
189	ZX-02716	Double Gear	2m48T	1
190	ZX-02303	Copper Sleeve		1
191	ZX-02734C	Positioning Sleeve		1
192	TS-1523031	Set Screw	M6x10	1
193	TS-1524041	Set Screw	M8x15	1
194	ZX-02733C	Blocking Piece		1
195	ZX-02718	Taper End Set Screw		1
196	ZX-02114C	Sleeve		1
197	BB-6203	Ball Bearing	17x40x12	1
198	ZX-H198	C-Clip	28	1
199	ZX-02717	Gear	2m65T	1
200	ZX-02715	Shaft		1
201	ZX-H201	Flat Key	5x5x1	1
202	ZX-H198	C-Clip	28	1
203	ZX-02722C	Sleeve		1
204	ZX-02301	Oil Bushing (serial # 101029ZX2256 and lower)		1
	CDL50002302	Oil Bushing (serial # 101214ZX2257 and higher)		1
205	ZX-08106A	Bracket (for Shaft V, Vb) (for 14"/16" models)		1
	ZX-08106B	Bracket (for Shaft V, Vb) (for 18" models)		1
	GH2280ZX-08106	Bracket (for Shaft V, Vb, Vc) (for 22" model)		1
206	ZX-H77	Taper Pin	8x40	1
207	TS-1505031	Hex Socket Cap Screw	M10x25	1
208	TNMP-08706A(N)	Gear (for 14"/16"/22" models)	3.5m16T	1
	TNMP-08706B(N)	Gear (for 18" models)	4m16T	1
209	ZX-02724C	Washer		1
210	ZX-H59	Pin	3n6x10	1
211	ZX-H211	Countersunk Head Screw	M5x16	1
221	VB-A75	V-Belt (for 14" models)	A-75	4
	VB-A76	V-Belt (for 16" models)	A-76	4
	VB-A77	V-Belt (for 18" models)	A-77	4
	VB-A85	V-Belt (for 22" model)	A-85	4
233	ZX-02506	Paper Gasket		2
234	ZX-H234	Set Screw	M8x6	2
235	ZX-02743N	Clamping Round Nut		1
236	ZX-H236	Pin	8 × 30	2
237	ZX-H237	Seal Ring (serial # 101214ZX2257 and higher)	25x40x70	1
238	ZX-H238	Steel C-clip (serial # 101214ZX2257 and higher)	32	1

7.0 Headstock Assembly III – Exploded View

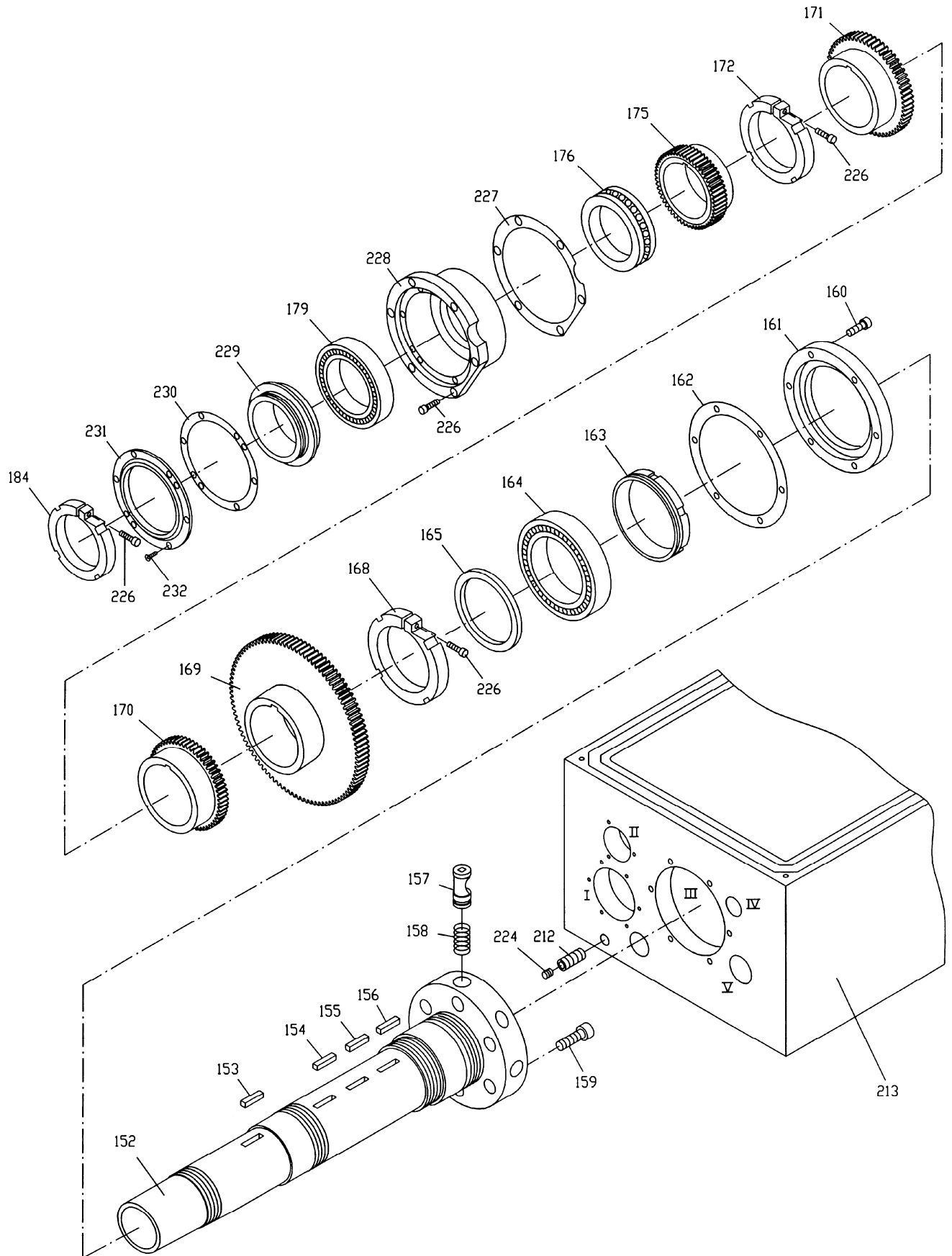

7.1 Headstock Assembly III – Parts List

Index No	Part No	Description	Size	Qty
152	ZX-02704	Spindle		1
153	ZX-H153	Flat Key	10x8x40	1
154	ZX-H154	Flat Key	10x8x50	1
155	ZX-H155	Flat Key	12x8x50	1
156	ZX-H156	Flat Key	14x9x50	1
157	ZX-02701	Cam Lock		6
158	ZX-H158	Spring	1x8x25	6
159	ZX-02703	Cam Positioning Screw		6
160	TS-1505041	Hex Socket Cap Screw	M10x28	6
161	ZX-02102	Bearing Front Cover		1
162	ZX-02501	Gasket		1
163	ZX-02702	Oil Splashing Ring		1
164	NN3024/P5	Taper Roller Bearing	120x180x46	1
165	ZX-02726	Lining		1
168	ZX-02725A	Round Nut w/Screw		1
169	ZX-02723	Gear	3m98T	1
170	ZX-02722	Gear	3m50T	1
171	ZX-02721	Gear	3m58T	1
172	ZX-02720A	Round Nut w/Screw		1
175	ZX-02710	Gear	2m65T	1
176	51120/P5	Thrust Bearing	100x135x25	1
179	BB-7020AC/P5	Angular Bearing	100x150x24	1
184	ZX-02713A	Round Nut w/Screw		1
212	ZX-H212	Drain Plug (14" models, serial # 001204ZX258 and lower)		1
	ZX-H212	Drain Plug (16" models, serial #010312ZX293 and lower, also includes serial # 010319ZX298 and 299)		1
	ZX-H212	Drain Plug (18" models, serial # 010416ZX313 and lower)		1
	ZX-H212A	Drain Plug (14" models, serial # 010105ZX263 and higher)		1
	ZX-H212A	Drain Plug (16" models, serial #010319ZX294 and higher, except for serial # 010319ZX298 and 299)		1
	ZX-H212A	Drain Plug (18" models, serial # 010514ZX323 and higher)		1
	ZX-H212A	Drain Plug (22" model)	Z3/8"	1
213	ZX-02101A	Headstock Casting (14" models, serial # 001204ZX258 and lower)		1
	ZX-02101AN	Headstock Casting (14" models, serial # 010105ZX263 and higher)		1
	ZX-01201B	Headstock Casting (16" models, serial # 010312ZX293 and lower, also includes serial # 110319ZX298 and 299)		1
	ZX-02101BN	Headstock Casting (16" models, serial # 010319ZX294 and higher, except for serial # 010319ZX298 and 299)		1
	ZX-02101C	Headstock Casting (18" models, serial # 010416ZX313 and lower)		1
	ZX-02101CN	Headstock Casting (18" models, serial # 010514ZX323 and higher)		1
	GH2280ZX-02101	Headstock Casting (22" model)		1
224	ZX-G38-3A	Screw		1
226	ZX-H226	Hex Socket Cap Screw	M8x28	9
227	ZX-02502F	Gasket		1
228	ZX-02108F	Bearing Support		1
229	ZX-02711F	Sleeve		1
230	ZX-02510F	Gasket		1
231	ZX-02761F	Bearing Back Cover		1
232	ZX-H232	Screw	M5x10	6

8.0 Headstock Assembly IV – Exploded View

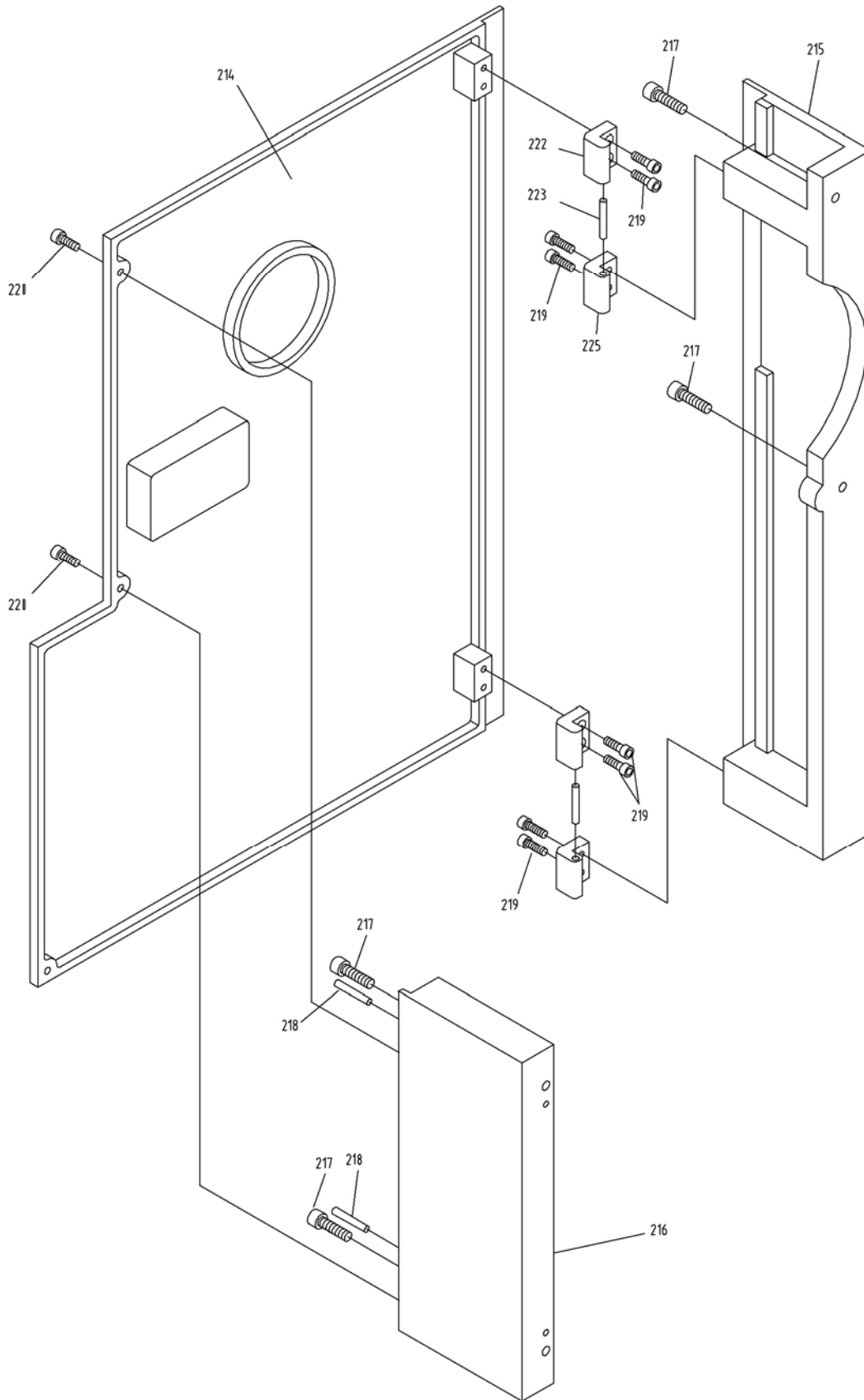

8.1 Headstock Assembly IV – Parts List

Index No	Part No	Description	Size	Qty
214	ZX-08302A	Back Cover (for 14" models)		1
	ZX-08302B	Back Cover (for 16" models)		1
	ZX-08302C	Back Cover (for 18" models)		1
	GH2280ZX-08301	Back Cover (for 22" model)		1
215	ZX-08114A	Rear Side Plate (for 14" models)		1
	ZX-08114B	Rear Side Plate (for 16" models)		1
	ZX-08114C	Rear Side Plate (for 18" models)		1
	GH2280ZX-08114	Rear Side Plate (for 22" model)		1
216	ZX-08113A	Front Side Plate (for 14" models)		1
	ZX-08113B	Front Side Plate (for 16" models)		1
	ZX-08113C	Front Side Plate (for 18" models)		1
	GH2280ZX-08113	Front Side Plate (for 22" model)		1
217	TS-1504051	Socket Cap Screw	M8x25	4
218	ZX-H218	Taper Pin	6x25	4
219	TS-1503051	Hex Socket Hd Cap Screw	M6x20	8
220	TS-1514021	Hex Socket Hd Cap Screw	M6x15	3
222	ZX-08712	Upper Hinge		2
223	ZX-H223	Pin	6n6x40	2
225	ZX-08711	Lower Hinge		2

9.0 Change Gear Box Assembly I – Exploded View

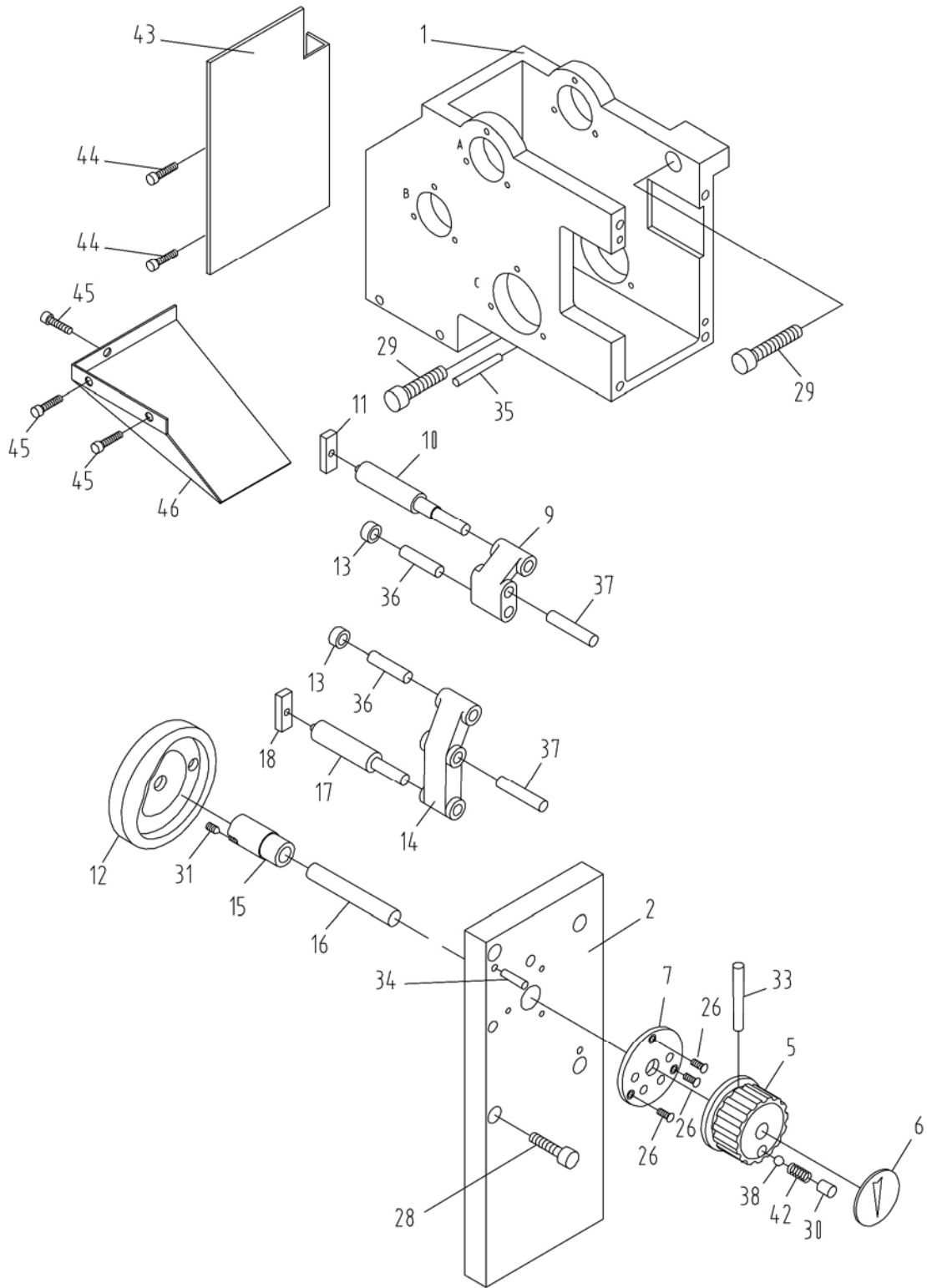

9.1 Change Gear Box Assembly I – Parts List

Index No	Part No	Description	Size	Qty
1	ZX-08101	Change Gear Box Casting		1
2	ZX-08108	Front Cover		1
5	ZX-05104C	Hand Wheel		1
6	ZX-05301C	Sign Plate		1
7	ZX-08708	Positioning Disc		1
8	ZX-08505	Gasket		1
9	ZX-08111	Crank		1
10	ZX-08705	Connecting Rod		1
11	ZX-08304	Sliding Block		1
12	ZX-05103C	Cam		1
13	ZX-05702C	Roller		2
14	ZX-08109	Crank		1
15	ZX-08110	Bushing		1
16	ZX-08704	Rotating Shaft		1
17	ZX-08703	Connecting Rod		1
18	ZX-08304	Sliding Block		1
26	ZX-C26	Cross Head Screw	M4x12	3
28	TS-1504051	Socket Cap Screw	M8x25	4
29	TS-1516051	Hex Socket Cap Screw	M10x40	2
30	TS-1525021	Set Screw	M10x12	1
31	ZX-C31	Flat Head Set Screw	M6x8	1
33	ZX-C33	Taper Pin	4x45	1
34	ZX-C34	Taper Pin	6x30	2
35	ZX-C35	Taper Pin	6x50	1
36	ZX-C36	Pin	10m6x40	2
37	ZX-C37	Pin	10m6x50	2
38	SB-8MM	Steel Ball	8	1
42	ZX-C42	Spring	1x8x30	1
43	ZX-08716	Splash Guard		1
44	TS-1534042	Cross Recessed Pen Head Screw	M6x12	2
45	TS-1533042	Cross Recessed Pen Head Screw	M5x12	3
46	ZX-08715	Splash Guard		1

10.0 Change Gear Box Assembly II – Exploded View

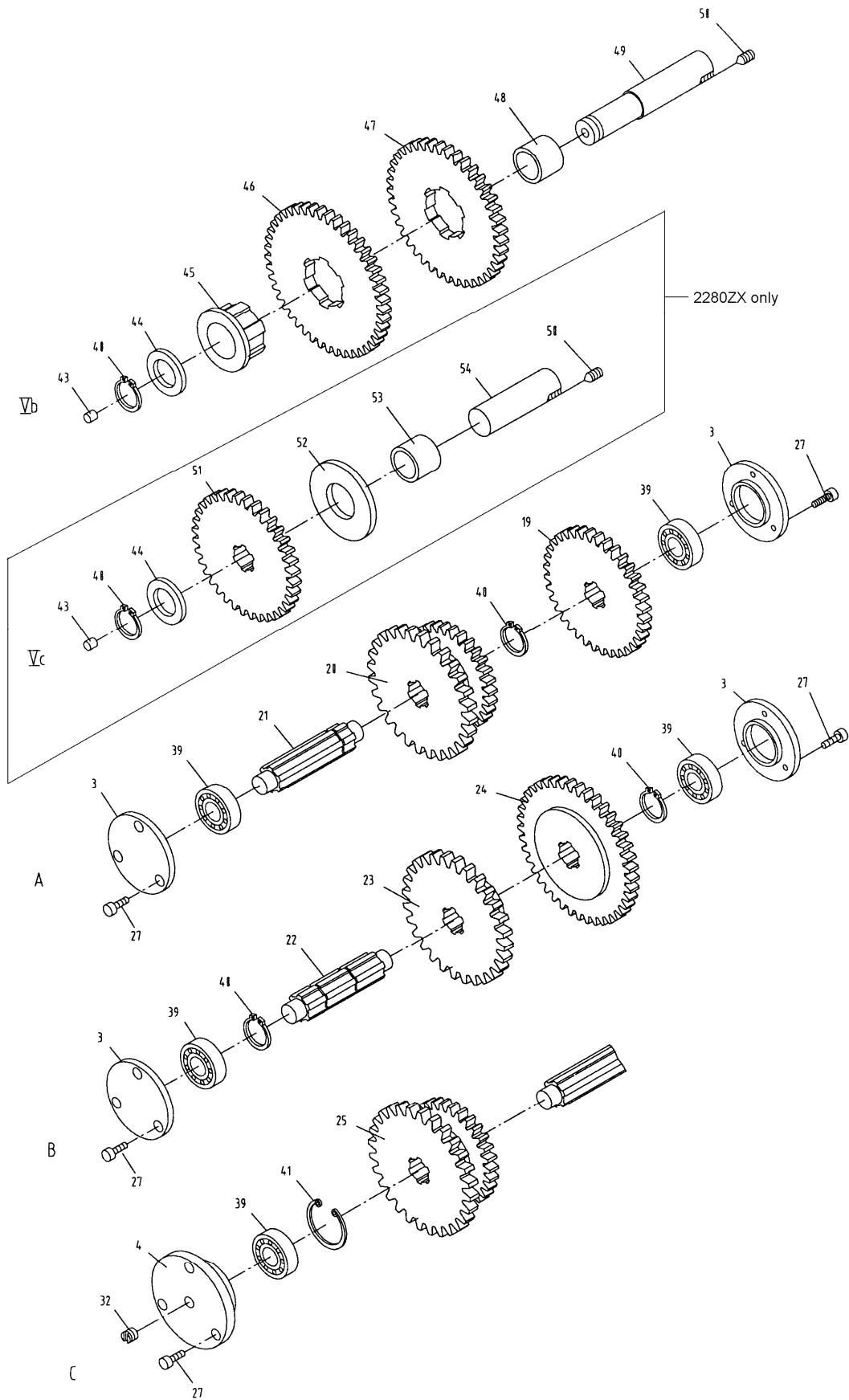

10.1 Change Gear Box Assembly II – Parts List

Index No	Part No	Description	Size	Qty
3	ZX-08104	End Cover		4
4	ZX-08103	Bearing Support		1
19	ZX-08107	Gear	3m36T	1
20	ZX-08105	Double Gear	3.75m28T/3m30T	1
21	ZX-08702	Shaft		1
22	ZX-08701	Shaft		1
23	ZX-08710	Gear	3.75m27T	1
24	ZX-08709	Gear	3m41T	1
25	ZX-08102	Double Gear	3.75m30T/3m29T	1
27	ZX-C27	Slotted Cheese Head Screw	M5x12	15
32	ZX-C32	Flat Head Set Screw	M10x12	1
39	BB-6203ZZ/P6	Ball Bearing	17x40x12	5
40	ZX-C40	C-Clip	25	4(5 for 22")
41	ZX-C41	C-Clip	40	1
43	ZX-C43	Oil Cup	8	1 (2 for 22")
44	TNMP08108	Washer		1 (2 for 22")
45	TNMP08102	Splined Sleeve		1
46	TNMP08504	Gear	3m41T	1
47	TNMP08501A	Gear (for 14"/16"/22" models)	3.5m36T	1
	TNMP08501B	Gear (for 18" models)	4m36T	1
48	ZX-05502C	Oil Bushing		1
49	ZX-08707	Shaft Vb		1
50	ZX-C50	Flat Head Set Screw	M8x10	1 (2 for 22")
51	GH2280ZX-08112	Gear (for 22" model)	3m30T	1
52	GH2280ZX-1052	Washer		1
53	GH2280ZX-1053	Oil Bushing		1
54	GH2280ZX-08707	Axis Vc (for 22" model)		1

11.0 Quick Change Gear Box I – Exploded View

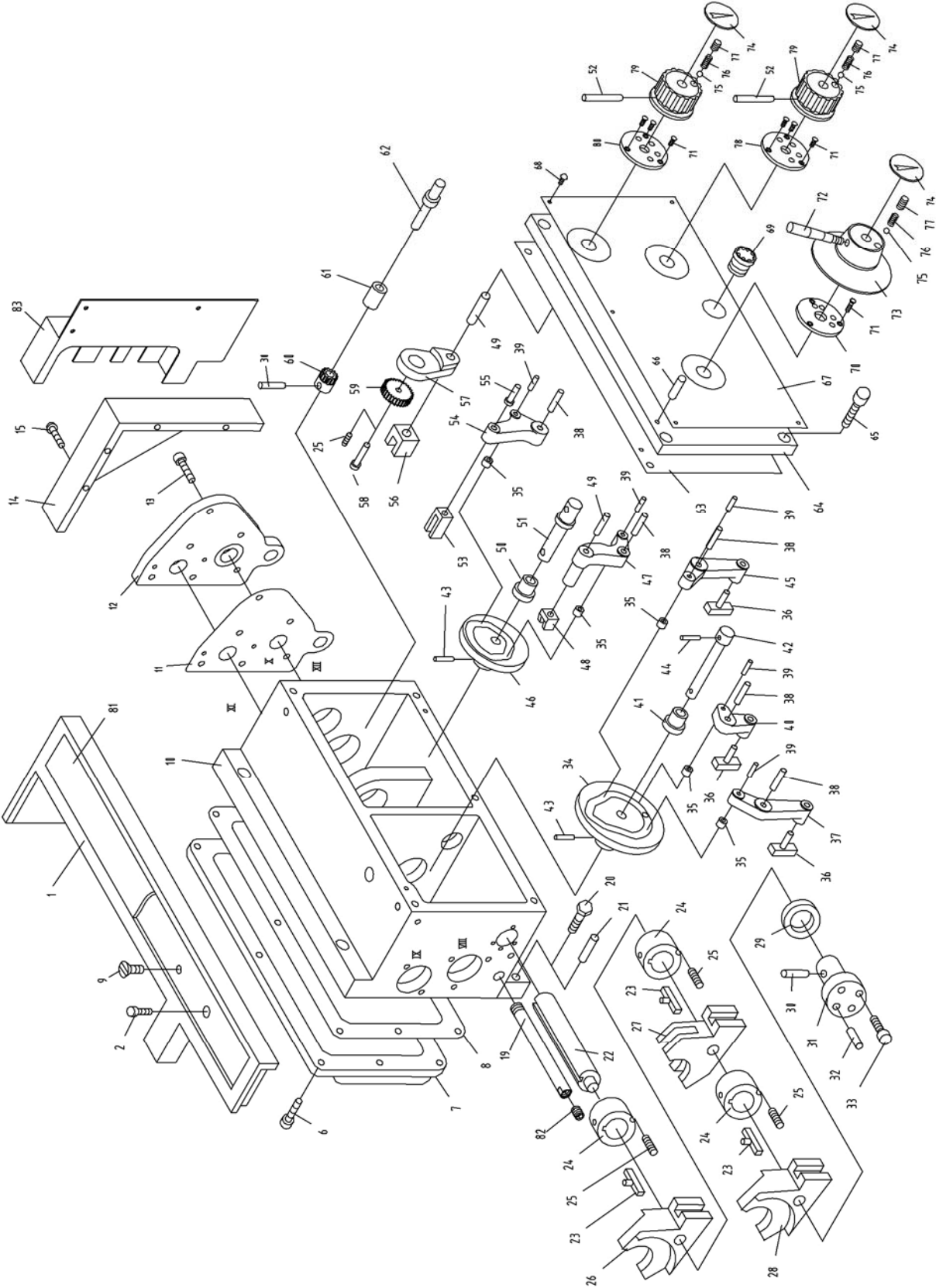

11.1 Quick Change Gear Box I – Parts List

Index No	Part No	Description	Size	Qty
1	ZX-05153A	Upper Cover		1
2	TS-1503071	Hex Socket Cap Screw	M6x30	2
6	TS-1504031	Hex Socket Cap Screw	M8x16	10
7	ZX-05109	Rear Cover		1
8	ZX-05502	Gasket		1
9	ZX-Q09	Countersunk Head Screw	M10x18	1
10	ZX-05101	Feedbox Casting		1
11	ZX-05501	Gasket		1
12	ZX-05108	Flange		1
13	TS-1504031	Hex Socket Cap Screw	M8x16	6
14	ZX-05151	Extending Plate		1
15	TS-1503131	Hex Socket Cap Screw	M6x60	4
19	ZX-Q19	Hex Cap Bolt	M10x1	1
20	TS-1491061	Hex Cap Bolt	M10x40	2
21	ZX-H68	Taper Pin	6x35	2
22	ZX-05738	Control Shaft		1
23	ZX-05739	Sliding Key		3
24	ZX-05128	Sliding Sleeve		3
25	ZX-Q25	Flat Head Set Screw	M5x8	4
26	ZX-05125	Right Fork		1
27	ZX-05126	Middle Fork		1
28	ZX-05127	Left Fork		1
29	ZX-Q29	Ring Seal	32x3.1	1
30	ZX-Q30	Taper Pin (serial #121220ZX2630 and lower)	4x25	2
	GB877-4x30	Taper Pin (serial #130102ZX2631 and higher)	4x30	2
31	ZX-05129	Cover		1
32	ZX-Q32	Pin	5n6x15	1
33	ZX-Q33	Cheese Head Screw	M5x16	3
34	ZX-05122	Cam		1
35	ZX-05728	Rolling Sleeve		5
36	ZX-05729	Poking Key		3
37	ZX-05123	Crank		1
38	ZX-Q38	Pin	8n6x32	5
39	ZX-Q39	Pin	6n6x20	5
40	ZX-05124	Crank		1
41	ZX-05111	Sleeve		1
42	ZX-05726	Lever Shaft		1
43	ZX-Q43	Taper Pin (serial #121220ZX2630 and lower)	4x32	2
	GB877-4x35	Taper Pin (serial #130102ZX2631 and higher)	4x35	2
44	ZX-Q44	Taper Pin	4x65	1
45	ZX-05121	Crank		1
46	ZX-05118	Cam		1
47	ZX-05120	Crank		1
48	ZX-05116	Fork		1
49	ZX-Q49	Pin	8n6x18	2
50	ZX-05117	Sleeve		1
51	ZX-05737	Lever Shaft		1
52	ZX-C33	Taper Pin	4x45	2
53	ZX-05115	Fork		1
54	ZX-05119	Crank		1
55	ZX-05735	Pin		1
56	ZX-05112	Fork		1
57	ZX-05113	Crank		1
58	ZX-05730	Small Shaft		1
59	ZX-05731	Big Gear	1m44T	1
60	ZX-05732	Small Gear	1m22T	1
61	ZX-05114	Sleeve		1
62	ZX-05734	Lever Shaft		1
63	ZX-05503	Gasket		1
64	ZX-05110	Front Cover		1

Index No	Part No	Description	Size	Qty
65	TS-1505021	Hex Socket Cap Screw	M10x20	5
66	ZX-Q66	Taper Pin	5x35	6
67	ZX-05303A	Sign Plate (serial #110930ZX2364 and lower)		1
	ZX-05303B	Sign Plate (serial #110930ZX2365 and higher)		1
68	ZX-Q68	Cross Head Screw	M3x6	7
69	ZX-Q69	Oil Sight Glass	20	1
70	ZX-05727	Positioning Disc		1
71	ZX-Q71	Countersunk Head Screw	M4x12	9
72	ZX-05740	Lever		1
73	ZX-05130A	Lever Support		1
74	ZX-05301	Sign Disc		3
75	SB-8MM	Steel Ball	8	3
76	ZX-Q76	Compression Spring	YZ-1x8x25	3
77	ZX-H3	Flat End Set Screw	M10x12	3
78	ZX-05736	Positioning Disc		1
79	ZX-05140	Hand Wheel		2
80	ZX-05733	Positioning Disc		1
81	C6136ZK-05551	Rubber Washer		1
82	ZX-Q82	Hex Socket Head Cap Screw	M8x5	1
83	1440R-05752A	Board		1

12.0 Quick Change Gear Box II – Exploded View

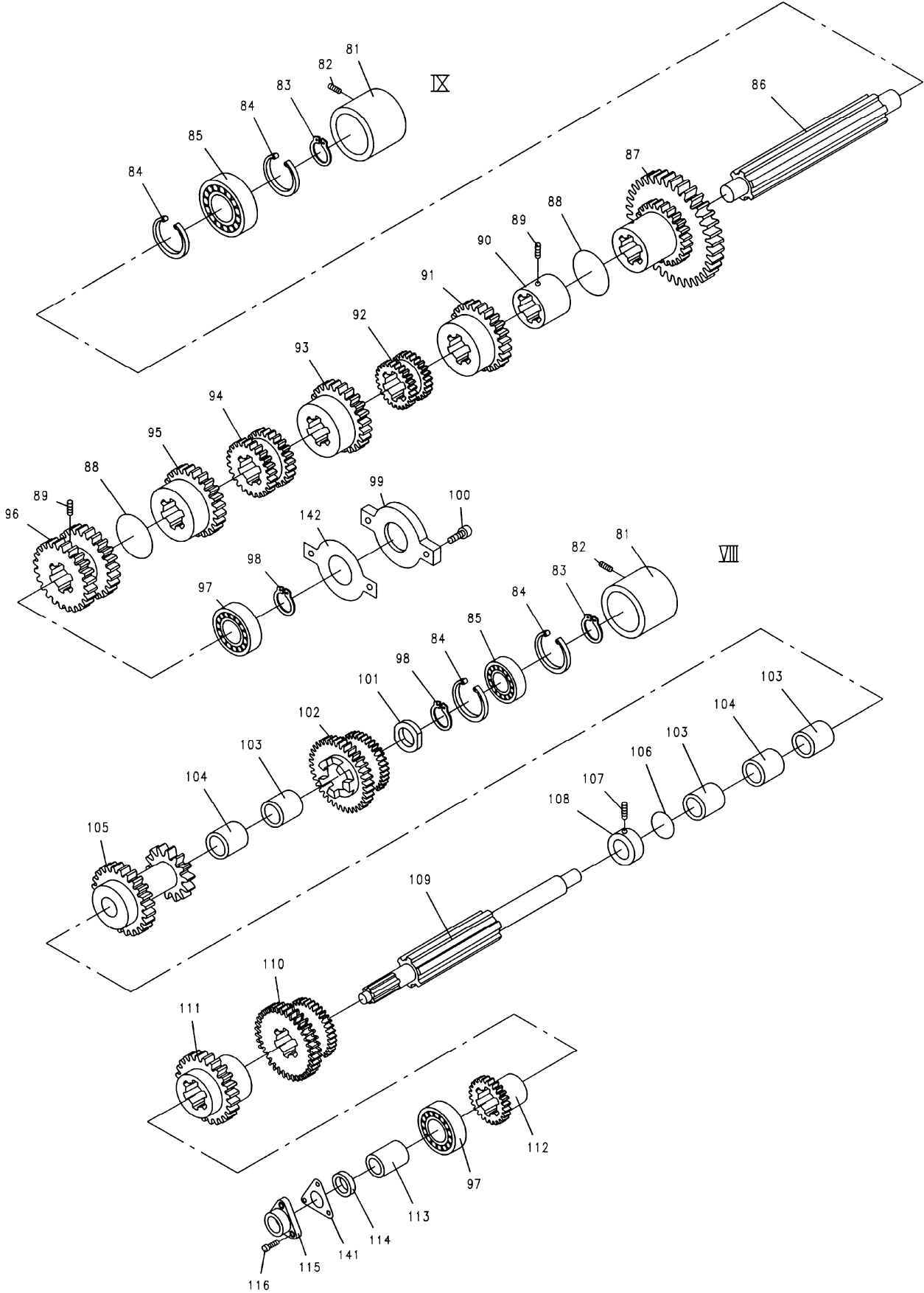

12.1 Quick Change Gear Box II – Parts List

Index No	Part No	Description	Size	Qty
81	ZX-05104	Middle Bearing Support		2
82	ZX-Q82	Taper End Set Screw	M10x16	2
83	ZX-B23	C-Clip	20	3
84	ZX-Q84	C-Clip	42	5
85	BB-6004	Single Row Radial Ball Bearing	20x42x12	5
86	ZX-05721	Shaft		1
87	ZX-05722	Double Gear	2m26T/2m52T	1
88	ZX-Q88	Iron Wire	1x190	2
89	TS-1524051	Set Screw	M8x20	2
90	ZX-05720	Positioning Sleeve		1
91	ZX-05719	Gear	2.25m28T	1
92	ZX-05718	Double Gear	2m26T/2m28T	1
93	ZX-05717	Gear	3.5m20T	1
94	ZX-05716	Double Gear	3.5m18T/3.5m19T	1
95	ZX-05715	Gear	3.25m22T	1
96	ZX-05714	Double Gear	3.25m24T/3.25m23T	1
97	BB-6205	Single Row Radial Ball Bearing	25x52x15	2
98	ZX-C40	C-Clip	25	3
99	ZX-05125	Shaft End Cover		1
100	TS-1504041	Hex Socket Cap Screw	M8x18	2
101	ZX-05704	Spacer		1
102	ZX-05705	Double Gear	2m52T/2m26T	1
103	ZX-05502C	Oil Bushing		3
104	ZX-05105	Sleeve		2
105	ZX-05707	Double Gear	2m39T/2m26T	1
106	ZX-Q106	Iron Wire	1x160	3
107	TS-1524031	Set Screw	M8x12	3
108	ZX-05714C	Fixed Bushing		1
109	ZX-05710	Shaft		1
110	ZX-05709	Double Gear	2m48T/2.25m42T	1
111	ZX-05711	Sliding Gear	3.5m24T	1
112	ZX-05712	Sliding Gear	3.25m24T	1
113	ZX-05713	Sleeve		1
114	ZX-G51-1	Spacer	32	1
115	ZX-05106	Bearing Support		1
116	TS-1504051	Hex Socket Cap Screw	M8x25	3
141	ZX-05504	Gasket		1
142	ZX-05505	Gasket		1

13.0 Quick Change Gear Box III – Exploded View

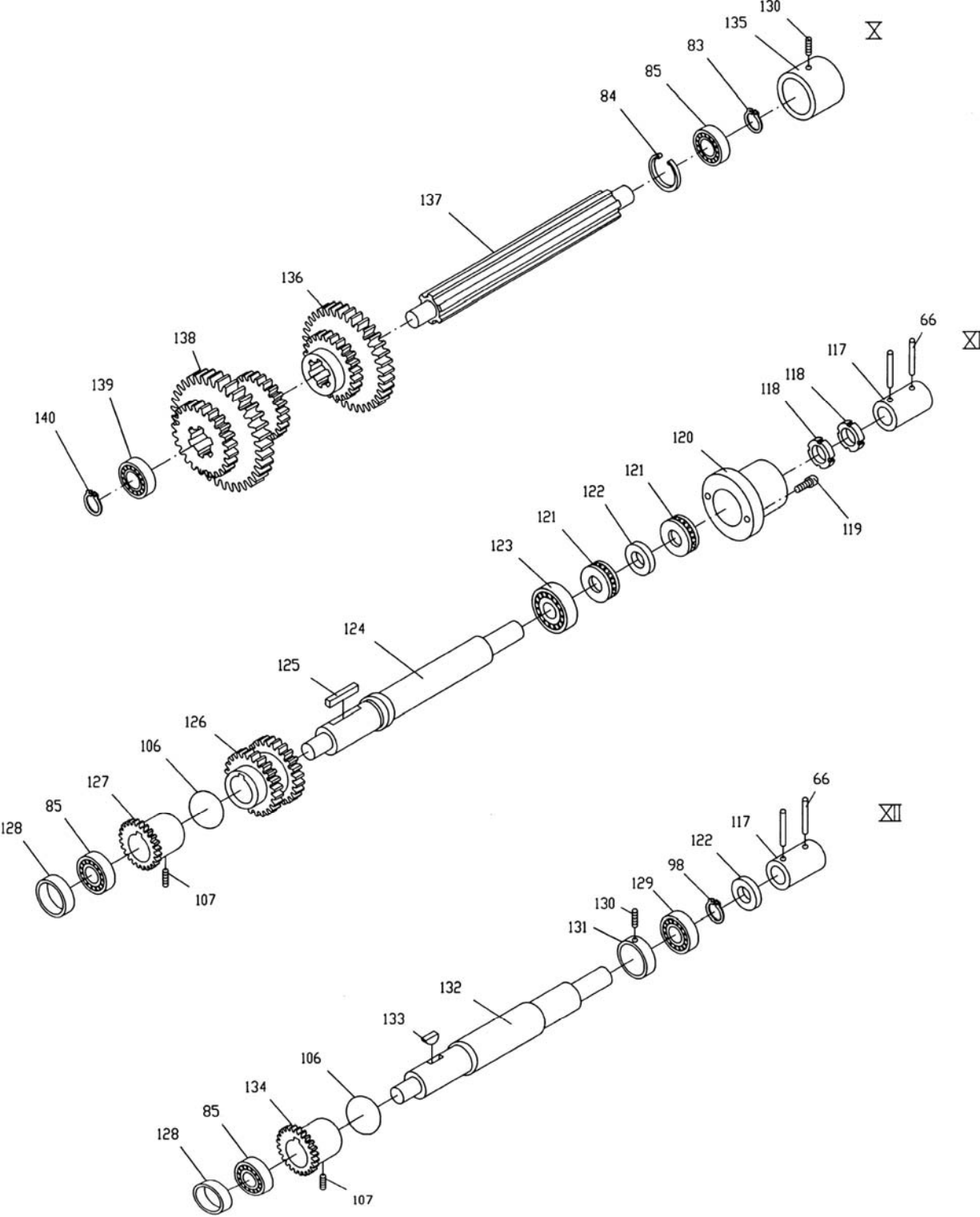

13.1 Quick Change Gear Box III – Parts List

Index No	Part No	Description	Size	Qty
66	ZX-Q66	Taper Pin	5x35	6
83	ZX-Q83	C-Clip	20	3
84	ZX-Q84	C-Clip	42	5
85	BB104	Single Row Radial Ball Bearing	20x42x12	5
98	ZX-Q98	C-Clip	25	3
106	ZX-Q106	Iron Wire	1x160	3
107	TS-1524031	Set Screw	M8x12	3
117	ZX-05113C	Shaft Coupling		2
118	ZX-Q118	Round Nut	M24x1.5	2
119	TS-1503021	Hex Socket Cap Screw	M6x10	2
120	ZX-05114C	Cover		1
121	BB-51105	Thrust Bearing	25x42x11	2
122	ZX-Q122	Spacer	25	2
123	BB-6305	Ball Bearing	25x62x17	1
124	ZX-05725	Shaft		1
125	ZX-Q125	Key	8x7x50	1
126	ZX-05724	Double Gear	2.25m35T/2.25m36T	1
127	ZX-05723	Gear	2.5m36T	1
128	ZX-05107	Sleeve		2
129	BB-6005	Ball Bearing	25x47x12	1
130	TS-1525021	Set Screw	M10x12	2
131	ZX-05103	Bearing Support		1
132	ZX-05701	Shaft		1
133	ZX-Q133	Half Circle Key	6x22	1
134	ZX-05703	Gear	2.5m36T	1
135	ZX-05102	Bearing Support		1
136	ZX-05702	Double Gear	2.5m24T/2.25m35T	1
137	ZX-05708	Shaft		1
138	ZX-05706	Triple Gear	2m39T/2m52T/2m26T	1
139	BB-6203	Ball Bearing	17x40x12	1
140	ZX-Q140	C-Clip	17	1

14.0 Apron Assembly I – Exploded View

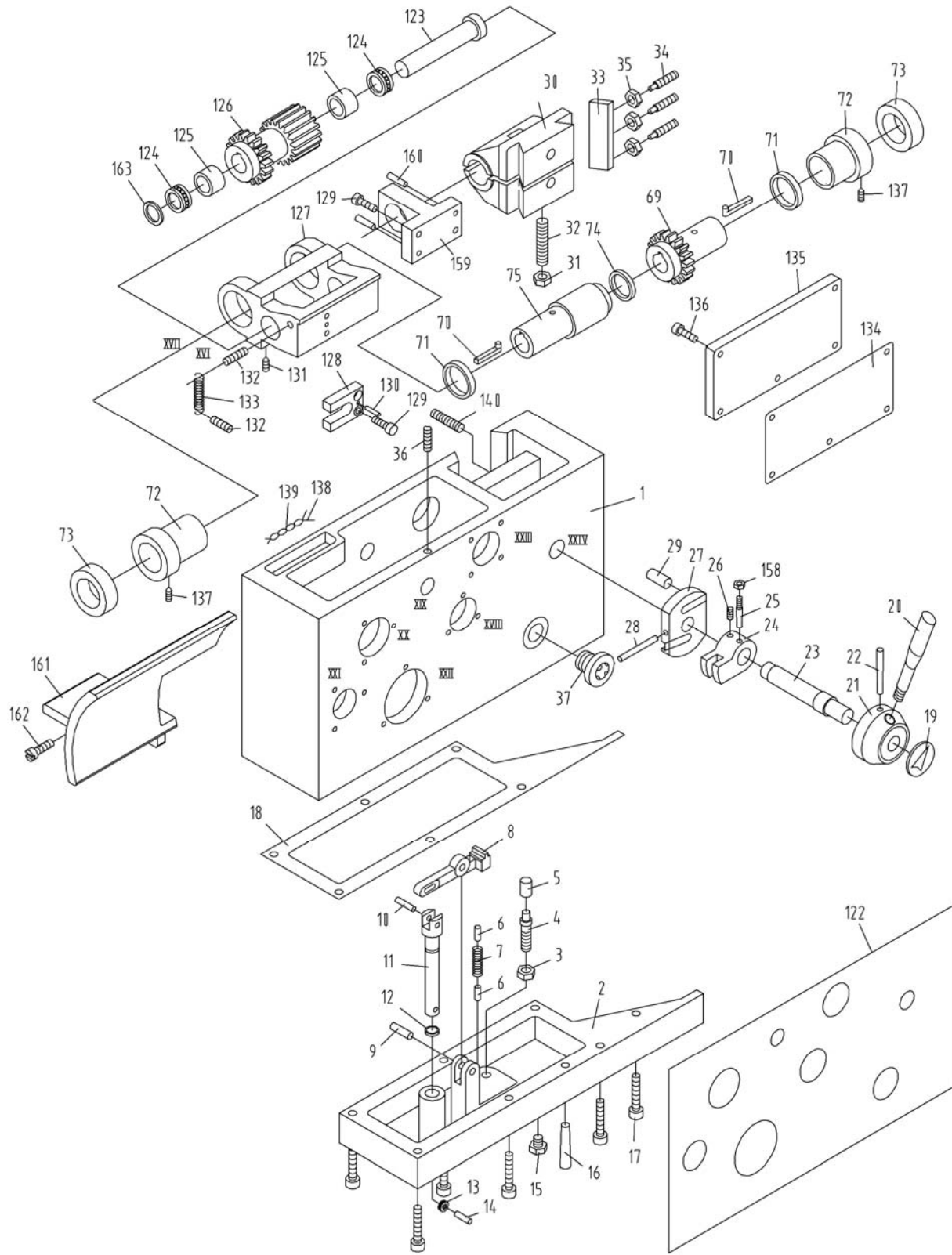

14.1 Apron Assembly I – Parts List

Index No	Part No	Description	Size	Qty
1	TL06101	Apron Casting		1
2	TL06103	Bottom Cover		1
3	TS-1540072	Hex Nut	M10	1
4	ZX-A4	Flat Head Set Screw	M10x70	1
5	TL06502	Cushion Cap		1
6	ZX-A6	Pin	6n6x16	2
7	ZX-A7	Tensile Spring	Y11.2x9x50	1
8	TL06734	Lever		1
9	ZX-A9	Pin	8n6x30	1
10	ZX-A10	Pin	6n6x18	1
11	TL06701-A	Pushing Rod		1
12	ZX-A12	Oil Seal	15x2.4	1
13	BB60016	Ball Bearing	6x17x6	1
14	ZX-A6	Pin	6n6x16	1
15	ZX-A15	Drain Plug	Z 1/4"	1
16	ZX-B34	Taper Pin	5x30	2
17	TS-1504041	Hex Socket Cap Screw	M8x20	6
18	TL06501	Gasket		1
19	TL06307	Sign Plate		1
20	TL06716	Lever		1
21	ZX-06122	Lever Support		1
22	ZX-B27	Taper Pin	6x60	1
23	TL06717	Half Nut Shaft		1
24	TL06111	Positioning Block		1
25	ZX-A25	Thread Tail Taper Pin	6x25	1
26	TS-1523031	Set Screw	M6x10	1
27	ZX-06733	Half Nut Control Plate		1
28	ZX-A28	Taper Pin	6x55	1
29	ZX-06732	Pin		2
30	ZX-06302	Half Nut (serial # 010611ZX349 and lower)		1
	ZX-06302N	New Half Nut (serial # 010618ZX350 and higher)		1
31	TS-1540072	Hex Nut	M10	1
32	ZX-A32	Cylindrical End Set Screw	M10x60	1
33	ZX-06121	Gib		1
34	ZX-06731	Cylindrical End Set Screw		3
35	TS-1540061	Hex Nut	M8	3
36	ZX-A36	Set Screw	M8x32	1
37	ZX-A37	Oil Sight Glass	20	1
69	TL06727	Gear (serial # 010611ZX349 and lower)	2m25T	1
	TL06727N	New Gear (serial # 010618ZX350 and higher)	2m25T	1
70	TL06728	Sliding Key		2
71	TL06121	Spacer (serial # 010611ZX349 and lower)		2
	TL06121N	New Spacer (serial # 010618ZX350 and higher)		2
72	TL06304	Positioning Sleeve (serial # 010611ZX349 and lower)		2
	TL06304N	New Positioning Sleeve (serial # 010618ZX350 and higher)		2
73	ZX-A73	Ring Seal For Rotating	3x55	2
74	ZX-A74	Oil Seal	35x3.1	1
75	TL06729	Sleeve (serial # 010611ZX349 and lower)		1
	TL06729N	New Sleeve (serial # 010618ZX350 and higher)		1
122	TL06302	Sign Plate		1
123	TL06730	Shaft		1
124	BB-51104	Thrust Bearing		2
125	TL06305	Sleeve		2
126	TL06726	Worm (serial # 010611ZX349 and lower)		1
	TL06726N	New Worm (serial # 010618ZX350 and higher)		1
127	TL06122	Worm Support (serial # 010611ZX349 and lower)		1
	TL06122N	New Worm Support (serial # 010618ZX350 and higher)		1
128	TL06720	Control Plate		1
129	TS-1514031	Hex Socket Cap Screw	M6x20	4
130	ZX-A130	Taper Pin	4x20	1

Index No	Part No	Description	Size	Qty
131	TS-1524031	Set Screw	M8x12	2
132	ZX-A132	Screw	M8x25	2
133	ZX-A133	Cylindrical Tensile Spring	LI-1.6x10x58	1
134	TL06503	Gasket		1
135	TL06114	Back Cover		1
136	TS-1514011	Hex Socket Cap Screw	M6x12	5
137	ZX-A137	Set Screw	M8x30	2
138	ZX-A138	Iron Wire	1x50	2
139	ZX-A139	Oil Conducting Cord	3x100	2
140	ZX-A140	Screw	M10x40	1
158	TS-1540041	Hex Nut	M6	1
159	TL06124	Bracket		1
160	ZX-A160	Taper Pin	5x25	2
161	TL06308	Bracket		1
162	TS-1503041	Hex Socket Cap Screw	M6x16	1
163	TL06120	Sleeve		1

15.0 Apron Assembly II – Exploded View

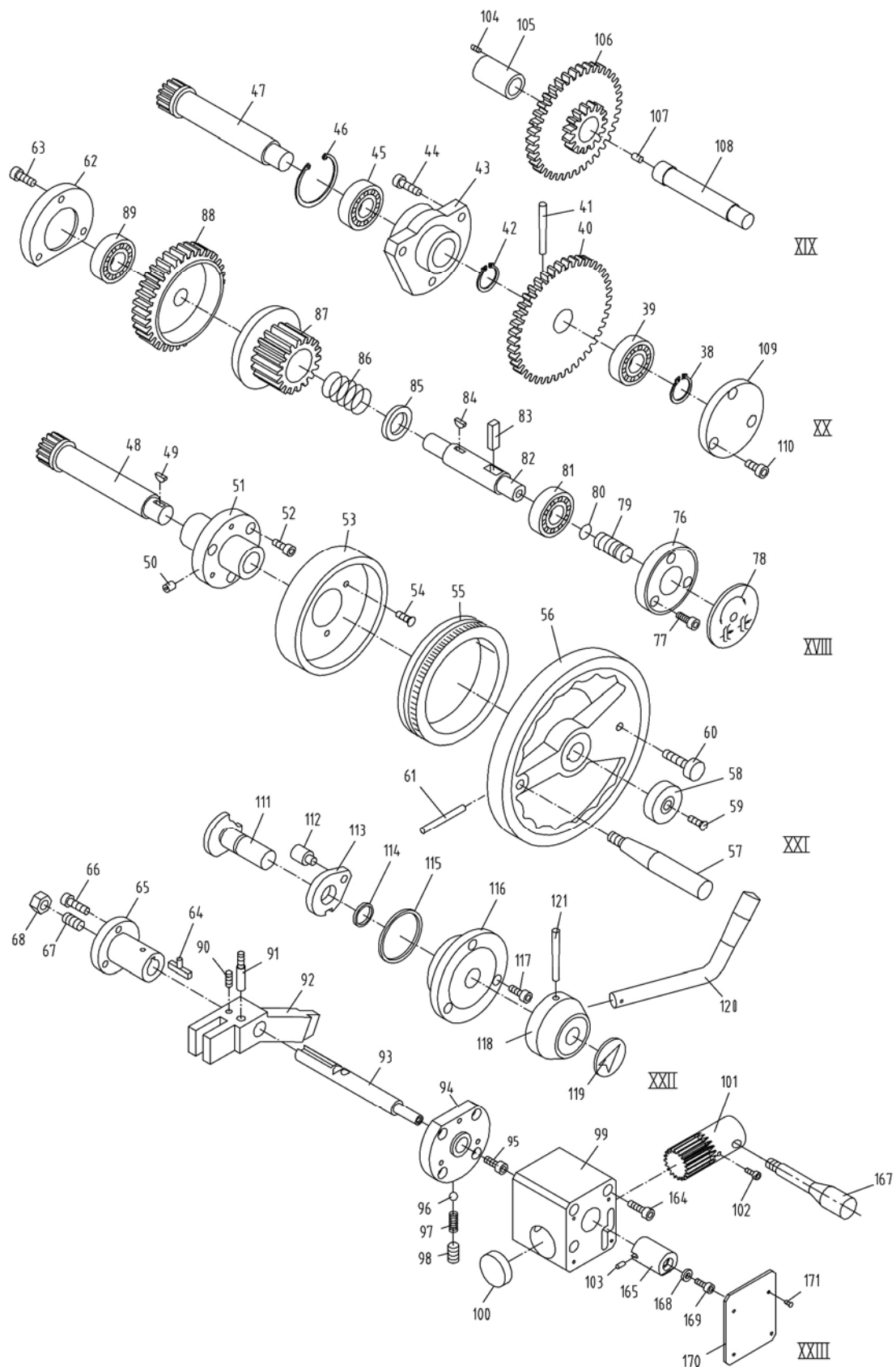

15.1 Apron Assembly II – Parts List

Index No	Part No	Description	Size	Qty
38	ZX-B23	C-Clip	20	1
39	BB-6204	Ball Bearing	20x47x14	1
40	TL06705	Gear	2m65T	1
41	ZX-A41	Taper Pin	6x40	1
	GB877-6x45	Taper Pin (serial #130102ZX2631 and higher)	6x45	1
42	ZX-C40	C-Clip	25	1
43	ZX-06127	Bearing Support (serial # 010611ZX349 and lower)		1
	ZX-06127N	New Bearing Support (serial # 010618ZX350 and higher)		1
44	TS-1504041	Hex Socket Cap Screw	M8x18	3
45	BB-6205Z	Ball Bearing	25x52x15	1
46	ZX-A46	C-Clip	52	1
47	TL06704	Shaft (serial # 010611ZX349 and lower)	2m14T	1
	TL06704N	New Shaft (serial # 010618ZX350 and higher)	2m14T	1
48	TL06706	Hand Wheel Shaft	2mx15T	1
49	ZX-H10	Half Circle Key	4x16	1
50	ZX-A50	Oil Cup	8	1
51	TL06104	Lever Support		1
52	TS-1503051	Hex Socket Cap Screw	M6x18	3
53	TL06105	Dial Support		1
54	ZX-A54	Cross Head Screw	M5x12	3
55	TL06732	Dial		1
56	TL06107	Hand Wheel		1
57	ZX-06710	Shaft Driven Lever		1
58	TL06709	Shaft Cover		1
59	ZX-A54	Cross Head Screw	M5x12	1
60	TL06708	Screw		1
61	TL06707	Pin		1
62	TL06112	End Cover		1
63	TS-1503031	Hex Socket Cap Screw	M6x12	3
64	TL06733	T Shaped Flat Key		1
65	TL06115	Flange Sleeve		1
66	TS-1503031	Hex Socket Cap Screw	M6x12	3
67	ZX-A67	Flat End Set Screw	M6x30	1
68	TS-1540041	Hex Nut	M6	1
76	TL06109	Flange		1
77	TS-1503031	Hex Socket Cap Screw	M6x12	3
78	TL06303	Sign Plate		1
79	TL06714	Adjusting Screw		1
80	ZX-A80	Oil Seal	8x1.9	1
81	BB-7203	Ball Bearing	17x40x12	1
82	TL06713	Shaft		1
83	TL06715	Adjusting Rod		1
84	ZX-H10	Half Circle Key	4x16	1
85	TL06712	Spring Cover		1
86	ZX-A86	Spring	YI-5x35x50	1
87	TL06718	Gear	2m28T	1
88	TL06113	Helical Gear	2.5m40T	1
89	BB7006/P6	Ball Bearing	30x55x13	1
90	TS-1523031	Set Screw	M6x10	1
91	ZX-A25	Thread Tail Taper Pin	6x25	1
92	TL06110	Fork		1
93	ZX-06721E	Control Rod (serial #120520ZX2472 and higher)		1
94	ZX-06116E	Lever Support (serial #120520ZX2472 and higher)		1
95	ZX-A95E	Cross Head Screw (serial #120520ZX2472 and higher)	M6x30	1
96	ZX-H5	Steel Ball (serial #120520ZX2472 and higher)	8	1
97	ZX-A97	Spring (serial #120520ZX2472 and higher)	YI-1x7x25	1
98	ZX-A98	Flat Head Set Screw (serial #120520ZX2472 and higher)	M10x16	1
99	ZX-06737E	Bracket (serial #120520ZX2472 and higher)		1
100	ZX-06741E	Plug (serial #120520ZX2472 and higher)		1
101	ZX-06739E	Gear Shaft (serial #120520ZX2472 and higher)		1

Index No	Part No	Description	Size	Qty
102	ZX-A102E	Hex Head Screw (serial #120520ZX2472 and higher)	M4x8	1
103	ZX-A103E	Pin (serial #120520ZX2472 and higher)	4x8	1
104	ZX-A104	Flat Head Set Screw	M4x8	1
105	TL06301	Sleeve		1
106	TL06710	Gear	2m21T/2m57T	1
107	ZX-A107	Pin	6n6x8	1
108	TL06711	Shaft		1
109	TL06108	End Cover		1
110	TS1514011	Hex Socket Cap Screw	M6x12	3
111	TL06723	Control Shaft		1
112	TL06725	Pin		1
113	TL06724	Control Block		1
114	ZX-A114	Oil Seal	20x2.4	1
115	ZX-A115	Oil Seal	50x3.1	1
116	TL06119	Lever Flange		1
117	TS1514011	Hex Socket Cap Screw	M6x12	3
118	TL06118	Lever Support (serial #120520ZX2472 and higher)		1
119	TL06307	Sign Plate		1
120	ZX-K06722	Lever (serial #120520ZX2472 and higher)		1
121	ZX-B27	Taper Pin	6x60	1
164	ZX-A164E	Hex Head Screw (serial #120520ZX2472 and higher)	M6x35	3
165	ZX-06738E	Rack (serial #120520ZX2472 and higher)		1
167	ZX-06740E	Handle (serial #120520ZX2472 and higher)		1
168	ZX-06736E	Washer (serial #120520ZX2472 and higher)		1
169	ZX-A169E	Hex Head Screw (serial #120520ZX2472 and higher)	M5x10	1
170	ZX-06303E	Label (serial #120520ZX2472 and higher)		1
171	ZX-A171E	Screw (serial #120520ZX2472 and higher)	M3x5	4

16.0 Apron Assembly III – Exploded View

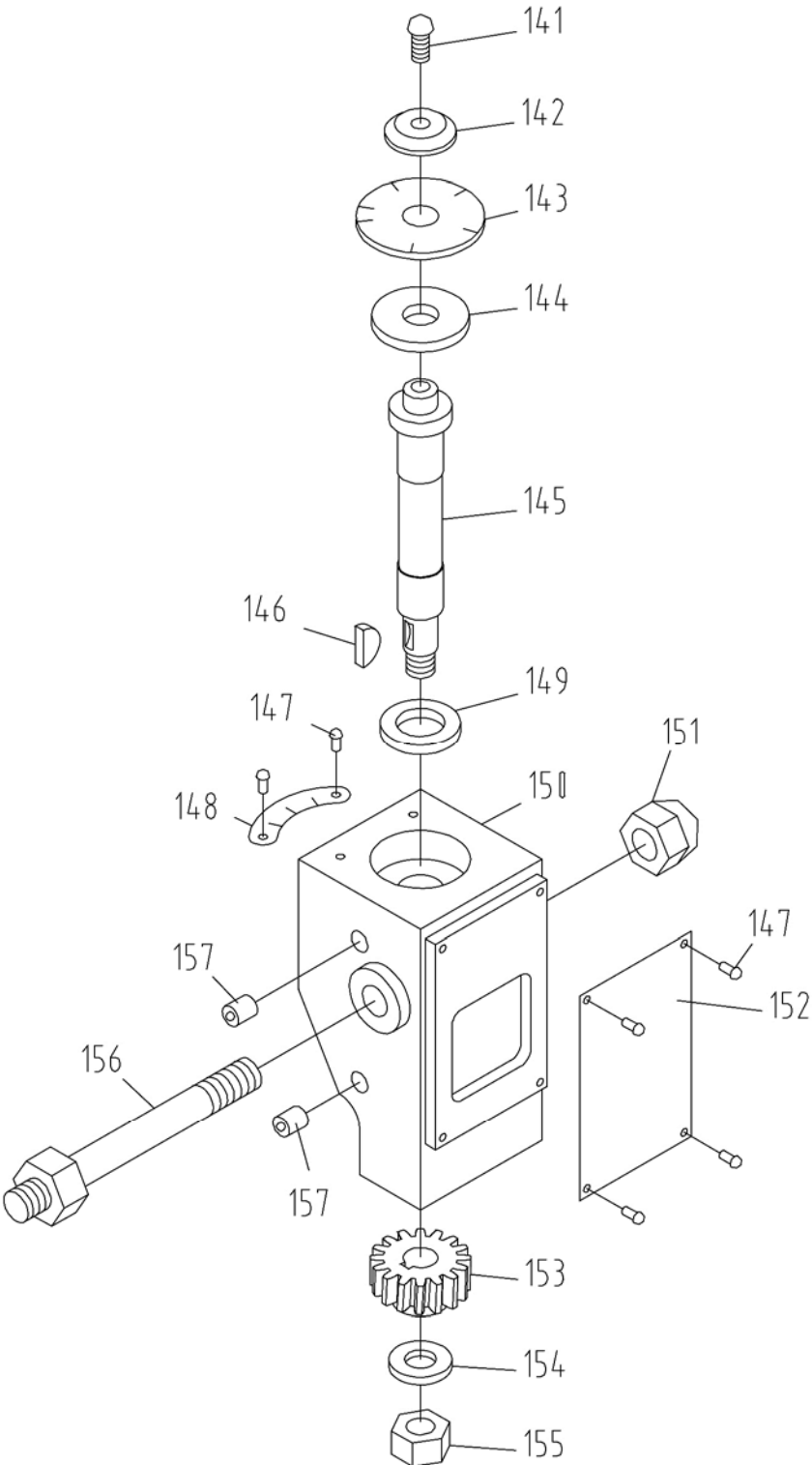

16.1 Apron Assembly III – Parts List

Index No	Part No	Description	Size	Qty
141	ZX-A141	Half Round Head Screw	M6x18	1
142	ZX-11704	Washer		1
143	ZX-11301	Dial		1
144	ZX-11105	Adjusting Washer		1
145	ZX-11701	Shaft		1
146	ZX-H10	Half Circle Key	4x16	1
147	ZX-A147	Half Round Head Screw	M3x6	6
148	ZX-11303	Positioning Sign Plate		1
149	ZX-11703	Adjusting Washer		1
150	ZX-11101	Casting		1
151	ZX-A151	Acorn Nut	M12	1
152	ZX-11304	Thread Chasing Label		1
153	ZX-11102	Helical Gear	2m16T	1
154	TS-1550071	Flat Washer	M10	1
155	TS-1540072	Hex Nut	M10	1
156	ZX-11702	Bolt		1
157	ZX-A157	Oil Cup	8	2

17.0 Carriage Assembly – Exploded View

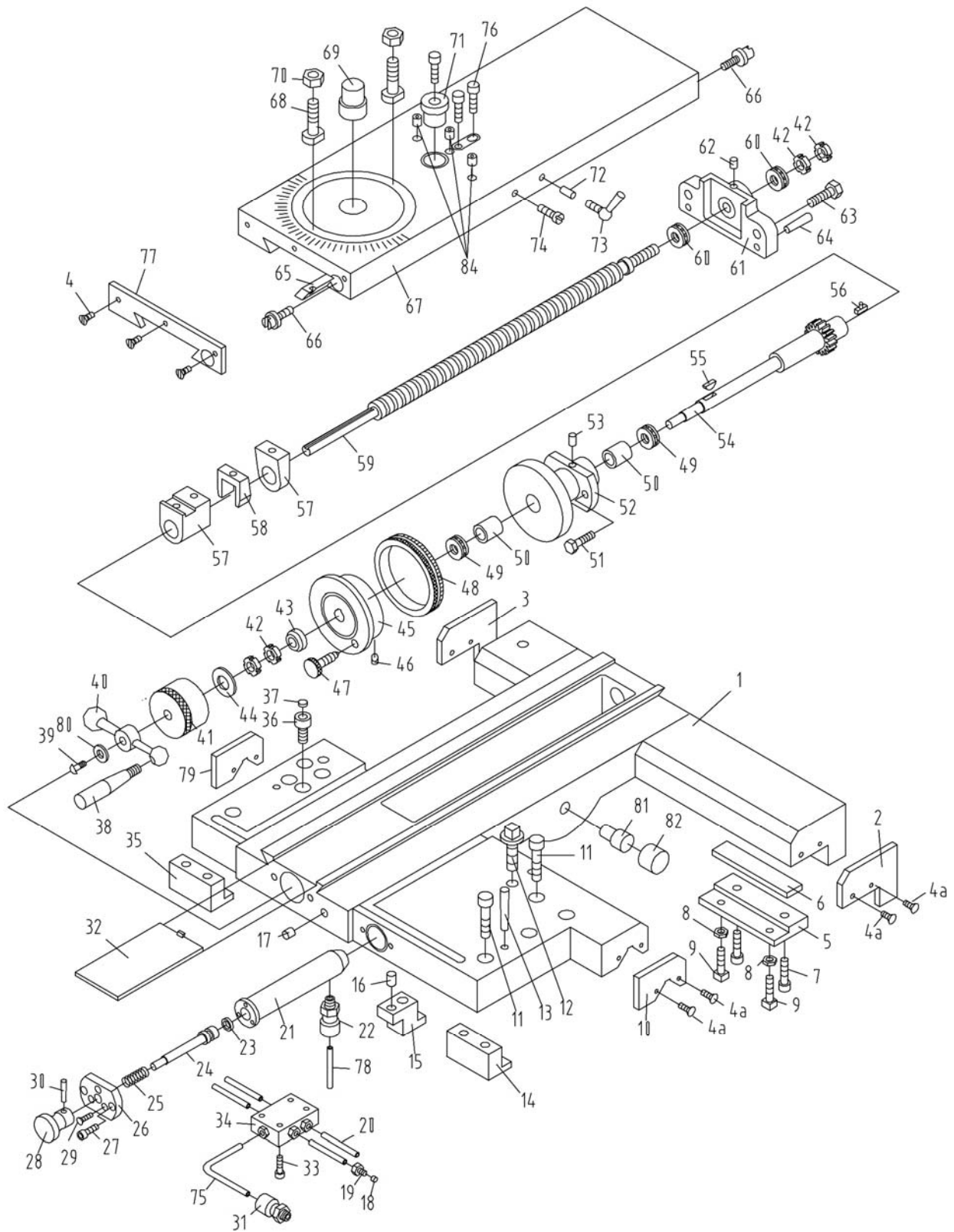

17.1 Carriage Assembly – Parts List

Index No	Part No	Description	Size	Qty
1	ZX-04101A	Saddle Casting		1
	GH2280ZX-14101	Saddle Casting (for 2280ZX)		1
2	ZX-04505	Wipe Plate (serial #100308ZX2172 and lower)		1
	ZX-04505J	Wipe Plate (serial #100329ZX2173 and higher)		1
3	ZX-04504	Wipe Plate (serial #100308ZX2172 and lower)		1
	ZX-04504J	Wipe Plate (serial #100329ZX2173 and higher)		1
4	ZX-H211	C'sunk Head Screw (serial #100308ZX2172 and lower)	M5x16	11
	ZX-C04	Half Round Head Screw (serial #100329ZX2173 and higher)	M5x16	11
5	ZX-04724	Clamping Block		2
6	ZX-04113	Lining Plate		2
7	TS-1505041	Hex Socket Cap Screw	M10x30	4
8	TS-1540061	Hex Nut	M8	4
9	ZX-CA09	Square Set Screw	M8x20	4
10	ZX-04506	Wipe Plate (serial #100308ZX2172 and lower)		1
	ZX-04506J	Wipe Plate (serial #100329ZX2173 and higher)		1
11	TS-1505071	Hex Socket Cap Screw	M10x45	8
12	ZX-CA12	Square Cap Bolt	M12x70	1
13	ZX-CA13	Taper Pin	8x60	2
14	ZX-04729	Clamping Block		1
15	ZX-04730	Locking Plate		1
16	ZX-CA16	Pin	4n6x12	1
17	ZX-04772	Blocking Piece		1
18	ZX-CA18	Fitting Joint Seal	A4	8
19	ZX-CA19	Hollowed Bolt	A4	8
20	ZX-CA20	Copper Tube		4
21	ZX-04782	Manual Oil Pump Casting		1
22	ZX-04781A	In Valve		1
23	ZX-CA23	Oil Ring	15x2.4	1
24	ZX-04784	Piston		1
25	ZX-CA25	Spring	1.2x14x65	1
26	ZX-04785	Oil Pump Cover		1
27	TS-1502041	Hex Socket Cap Screw	M5x16	2
28	ZX-04783	Lever		1
29	ZX-CA29	Countersunk Head Screw	M4x16	3
30	ZX-A130	Taper Pin	4x20	1
31	ZX-04781B	Out Valve		1
32	ZX-04716	Chip Guard		1
33	ZX-CA33	Slotted Cheese Head Screw	M5x20	4
34	ZX-04780	Oil Distributor		1
35	ZX-04740	Clamping Block		1
36	ZX-04750	Oil Cap		1
37	ZX-04301	Oil Indicator Cap		1
38	ZX-04721	Lever		1
39	ZX-CA39	Cross Head Screw	M5x16	1
40	ZX-04720	Handle		1
41	ZX-04769	Sleeve		1
42	ZX-CA42	Round Nut	M12x1.25	4
43	ZX-04719	Lining		1
44	ZX-04770	Disc Spring		1
45	ZX-04108	Flat Pan		1
46	ZX-04790	Pushing Rod		1
47	ZX-04789	Screw		1
48	ZX-04717	Dial		1
49	BB-51102	Thrust Bearing	15x28x9	2
50	ZX-04111	Sleeve		2
51	TS-1490041	Hex Cap Bolt	M8x25	2
52	ZX-04109	Screw Support		1
	GH2280ZX-04109B	Screw Support (for 2280ZX)		1
53	ZX-CA53	Oil Cup	8	2

Index No	Part No	Description	Size	Qty
54	ZX-04707-1	Gear Sliding Sleeve	2m16T	1
	ZX-04707-1A	Gear Sliding Sleeve (for 2280ZX)		1
55	ZX-H10	Half Circle Key	4x16	1
56	ZX-04751	Flat Key		1
57	ZX-04302	Nut Assembly		1
	ML-2080-04301	Nut Assembly (for 2280ZX)		1
58	ZX-04748	Wedge		1
59	ZX-04707-2	Lead Screw		1
	GH2280ZX-04707-2	Lead Screw (for 2280ZX)		1
60	BB-51101/P6	Thrust Bearing	12x26x9	2
61	ZX-04116	Bracket		1
62	ZX-CA62	Oil Cup	6	1
63	TS-1491041	Cap Screw	M10x30	2
64	ZX-CA64	Taper Pin	8x30	2
65	ZX-04731	Cross Slide Gib		1
66	ZX-04725C	Screw		2
67	ZX-04102A	Cross Slide		1
	GH2280ZX-04102	Cross Slide (for 2280ZX)		1
68	ZX-04714	Screw (for 18"/22" models, T-Slot)		2
	ZX-04714C	Screw (for 14"/16" models, T-Slot)		2
69	ZX-04732	Pin		1
70	TS-1540081	Hex Nut	M12	2
71	ZX-04709	Sleeve		1
	GH2280ZX-04701	Sleeve (for 2280ZX)		1
72	ZX-04304	Pressing Pin	1	1
73	ZX-04746	Screw		1
74	ZX-04786	Set Screw		1
75	ZX-CA75	Long Copper Tube		1
76	TS-1504051	Socket Head Cap Screw	M8x22	3
77	ZX-04502	Wipe Plate (serial #100308ZX2172 and lower)		1
	ZX-04502J	Wipe Plate (serial #100329ZX2173 and higher)		1
	GH2280ZX-04502	Wipe Plate (for 2280ZX)(serial #100308ZX2172 and lower)		1
	GH2280ZX-04502J	Wipe Plate (for 2280ZX)(serial #100329ZX2173 and higher)		1
78	ZX-CA78	Copper Tube		6
79	ZX-04503	Wipe Plate (serial #100308ZX2172 and lower)		1
	ZX-04503J	Wipe Plate (serial #100329ZX2173 and higher)		1
80	ZX-04771	Lining		1
81	ZX-04788	Stop Pin		1
82	ZX-04507	Stop Pin Cap		1
83	ZX-CA83	Oil Cup	10	1
84	ZX-CA84	Oil Cup	10	3
85	ZX-CA85	Turcite-B (not shown)	550x50x0.8	1
86	ZX-CA86	Turcite-B (not shown)	550x25x0.8	2
	ZX-CSNA	Crossfeed Screw & Nut Assy. (includes # 57- 59, for 14/16/18")		
	ZX-CSNA-GH2280ZX	Crossfeed Screw & Nut Assy. (includes #57-59, for 22")		
	ZX-CDA	Crossfeed Dial Assy. (includes # 41-50, 51-56, for 14/16/18")		
	ZX-CDA-GH2280ZX	Crossfeed Dial Assy. (includes # 41-50, 51-56, for 22")		

18.0 Micro Carriage Stop – Exploded View

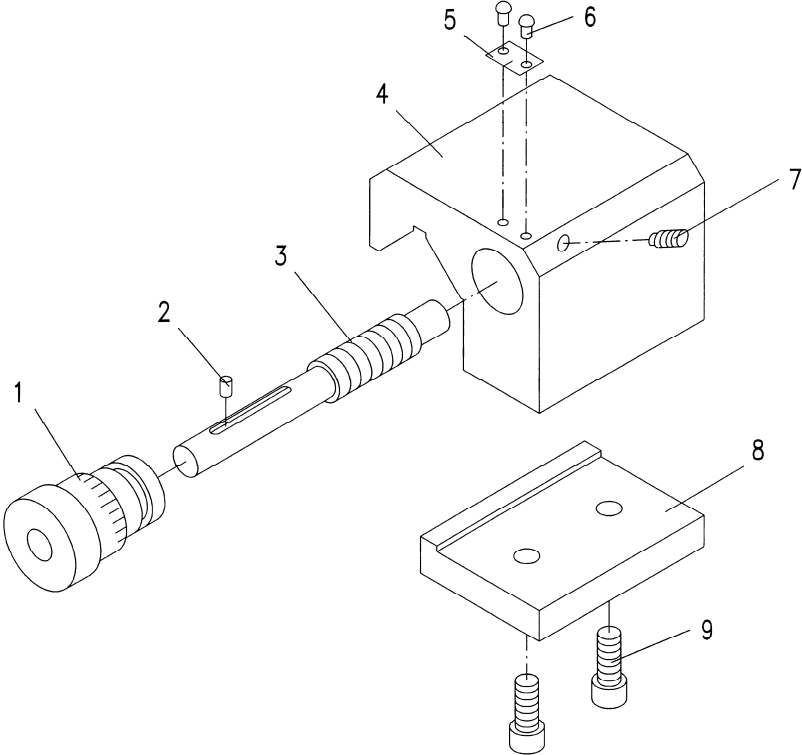

18.1 Micro Carriage Stop – Parts List

Index No	Part No	Description	Size	Qty
1	ZX-09709	Dial		1
2	ZX-MS2	Pin	B4x8	1
3	ZX-09708	Axle		1
4	ZX-09105	Stop		1
5	ZX-03302	Sign Plate		1
6	ZX-MS6	Nail	3x8	2
7	ZX-MS7	Hex Socket Set Screw	M6x12	1
8	ZX-09106	Clamping Plate		1
9	ZX-MS9	Hex Socket Cap Screw	M8x20	2

19.0 Carriage Stop Assembly – Exploded View

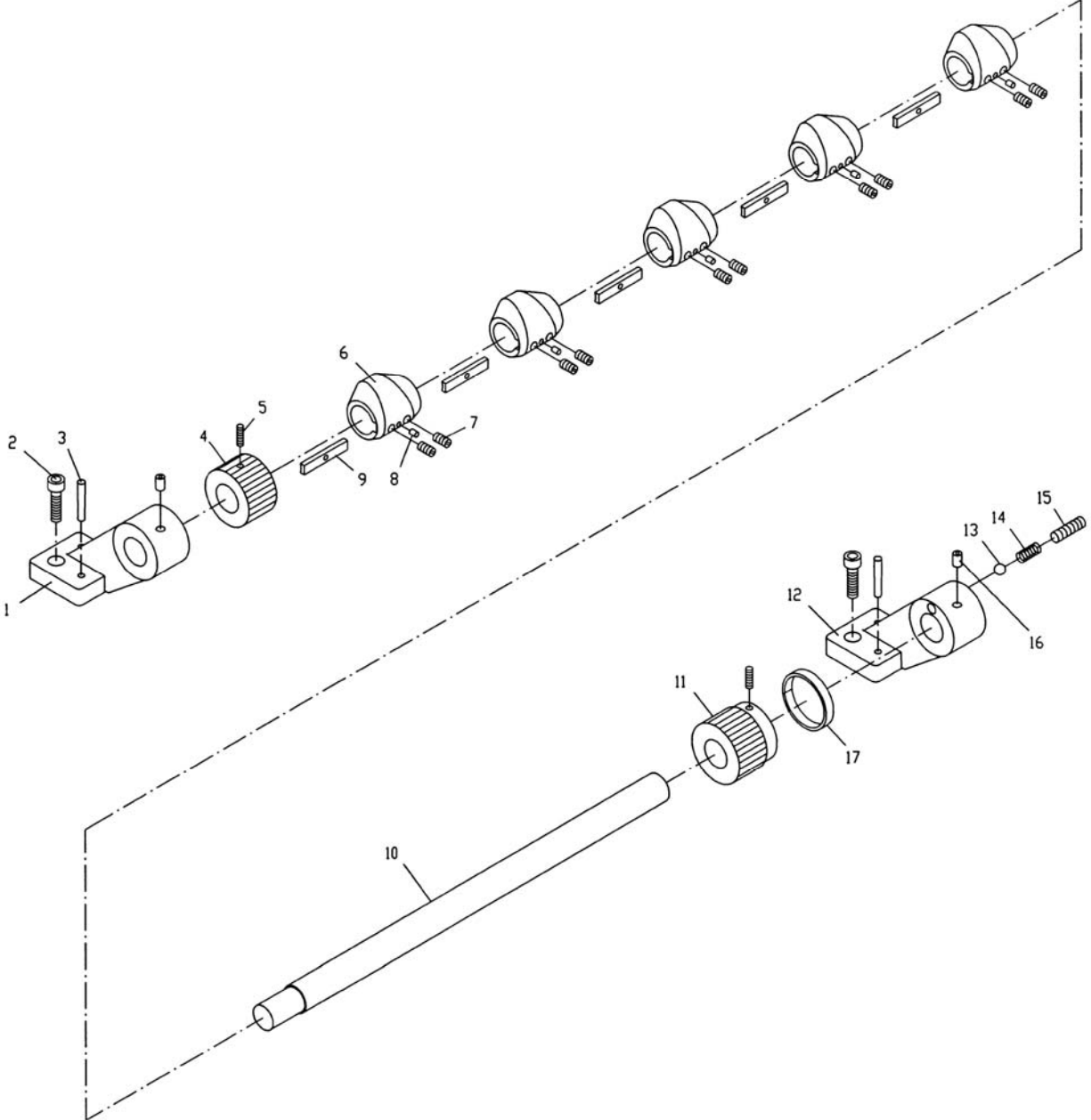

19.1 Carriage Stop Assembly – Parts List

Index No	Part No	Description	Size	Qty
1	ZX-26101	Left Support		1
2	TS-1504041	Hex Socket Cap Screw	M8x20	4
3	ZX-C34	Taper Pin	6x30	4
4	ZX-26704	Control Ring		1
5	TS-1523031	Set Screw	M6x10	2
6	ZX-26702	Eccentric Travel Setting Ring		5
7	ZX-H66	Flat End Set Screw	M6x10	10
8	ZX-C08	Pin	4n6x10	5
9	ZX-26703	Locking Key		5
10	ZX-26701A	Travel Setting Rod (for 1440/1640/1840ZX)		1
	ZX-26701B	Travel Setting Rod (for 1460/1660/1860ZX)		1
	ZX-26701C	Travel Setting Rod (for 1880/2280ZX)		1
11	ZX-26705	Control Ring		1
12	ZX-26104	Right Support		1
13	ZX-H5	Steel Ball	8	1
14	ZX-CS14	Compression Spring	2x8x25	1
15	ZX-CS15	Flat Head Set Screw	M10x12	1
16	ZX-CS16	Oil Cup	8	2
17	ZX-26301	Dial		1

20.0 Four Way Tool Post – Exploded View

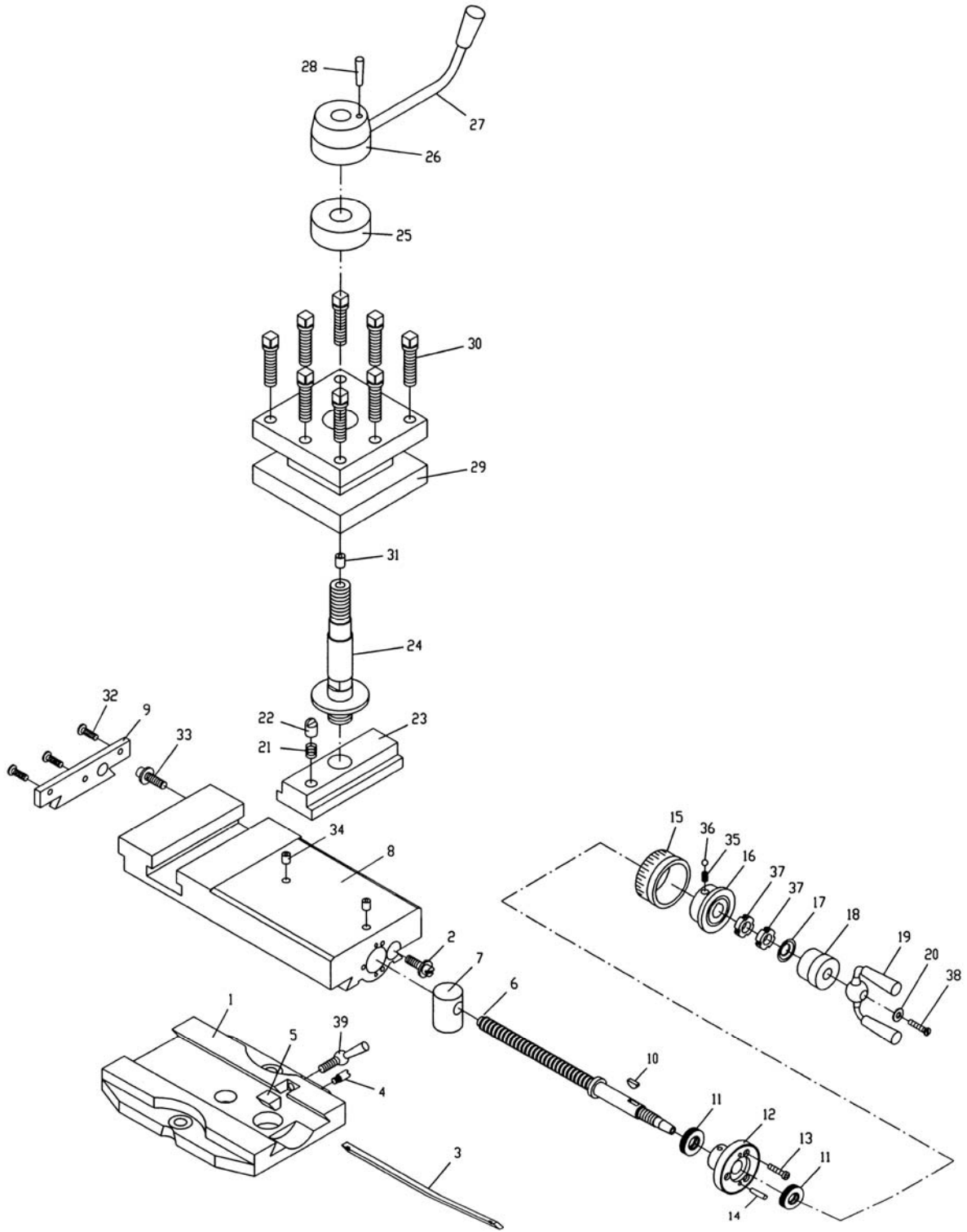

20.1 Four Way Tool Post – Parts List

Index No	Part No	Description	Size	Qty
1	ZX-04103A	Revolving Plate (for 14" models)		1
	ZX-04103B	Revolving Plate (for 16" models)		1
	ZX-04103C	Revolving Plate (for 18" models)		1
	GH2280ZX-04103	Revolving Plate (for 22" model)		1
2	ZX-04725	Screw		1
3	ZX-04710	Gib		1
4	ZX-04786	Screw		1
5	ZX-04303	Pressing Block		1
6	ZX-04706	Lead Screw		1
7	ZX-04106A	Nut		1
8	ZX-04107A	Top Slide (for 14" models)		1
	ZX-04107B	Top Slide (for 16"/18" models)		1
	GH2280ZX-04107	Top Slide (for 22" model)		1
9	ZX-04501	Wipe Plate		1
10	ZX-F10	Half Circle Key	3x13	1
11	BB-51102	Thrust Bearing	15x28x9	2
12	ZX-04115	Sleeve		1
13	ZX-F13	Slotted Cheese Head Screw	M5x12	3
14	ZX-F14	Taper Pin	3x18	2
15	ZX-04727	Dial		1
16	ZX-04114	Sleeve		1
17	ZX-04768	Disc Spring		1
18	ZX-04767	Sleeve		1
19	ZX-04726	Handle		1
20	ZX-04771	Lining		1
21	ZX-04763	Spring	0.8x6x25	1
22	ZX-04787	Positioning Block		1
23	ZX-04752A	T-Slot Nut		1
24	ZX-04754	Shaft		1
25	ZX-04759	Adjusting Lining Sheet		1
26	ZX-04110	Lever Support		1
27	ZX-04753	Handle		1
28	ZX-Q66	Taper Pin	5x35	1
29	ZX-04713A	Tool Post (for 14" models)		1
	ZX-04713B	Tool Post (for 16"/18"/22" models)		1
30	ZX-F30A	Clamping Screw (for 16"/18"/22" models)	M12x45	8
	ZX-F30B	Clamping Screw (for 14" models)	M12x50	8
31	ZX-F31	Oil Cup	8	1
32	ZX-H211	Countersunk Head Screw	M5x16	3
33	ZX-04725C	Screw		1
34	ZX-F34	Oil Cup	8	2
35	ZX-F35	Spring	0.7x5x9	1
36	ZX-F36	Steel Ball	6	1
37	ZX-F37	Round Nut	M12x1.25	2
38	ZX-CA39	Cross Head Screw	M5x16	1
39	ZX-04746K	Screw Wrench		1
	ZX-TA14	Toolholder Assembly 14" (includes # 29 & 30)		
	ZX-TA16/18/22	Toolholder Assembly 16"/18"/22" (includes # 29 & 30)		
	ZX-CPA14	Compound Assembly 14" (includes # 1-20,32-39)		
	ZX-CPA16	Compound Assembly 16" (includes # 1-20,32-39)		
	ZX-CPA18	Compound Assembly 18" (includes # 1-20,32-39)		
	ZX-CPA22	Compound Assembly 22" (includes # 1-20,32-39)		

21.0 Tailstock Assembly I – Exploded View

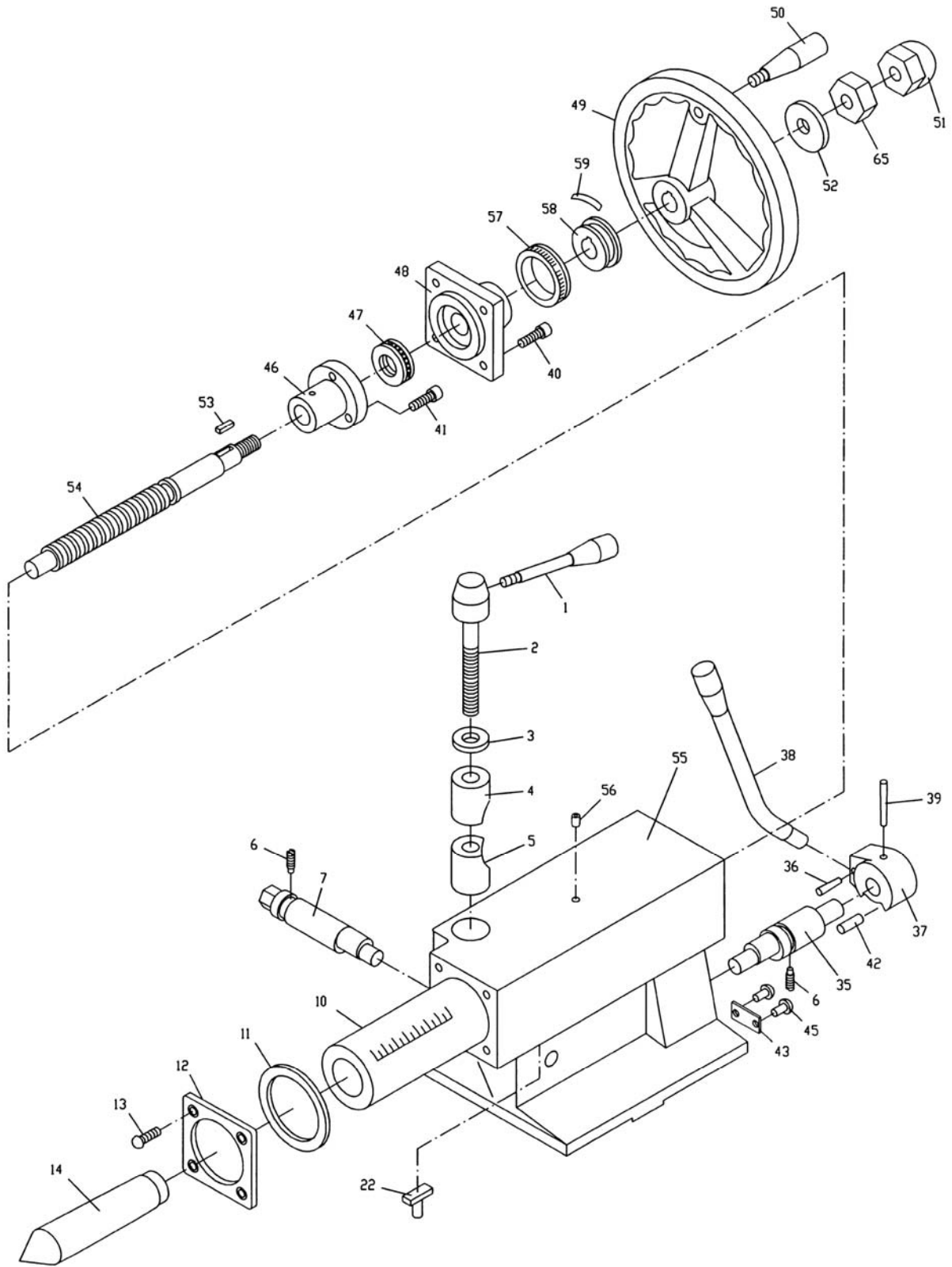

21.1 Tailstock Assembly I – Parts List

Index No	Part No	Description	Size	Qty
1	ZX-03711	Handle		1
2	ZX-03717	Lever Support		1
3	ZX-03718	Washer		1
4	ZX-03719	Clamping Block		1
5	ZX-03720	Clamping Block		1
6	ZX-T06	Cylindrical End Set Screw	M8x14	2
7	ZX-03712	Eccentric Shaft		1
10	ZX-03701A	Center Sleeve (for 18"/22" models)		1
	ZX-03701B	Center Sleeve (for 14"/16" models)		1
11	ZX-T11	Ring Seal	75x2.65	1
12	ZX-03703	Front Cover		1
13	ZX-T13	Cross Recessed Countersunk Head Screw	M5x10	4
14	ZX-T14A	Center Morse (for 18"/22" models)	No.5	1
	ZX-T14B	Center Morse (for 14"/16" models)	No.4	1
22	ZX-03702	Positioning Block		1
35	CL1640ZX-0535	Eccentric Shaft		1
36	ZX-T36	Taper Pin	6x32	1
37	ZX-03104	Lever Sleeve		1
38	ZX-03709	Lock handle		1
39	ZX-A28	Taper Pin	6x55	1
40	TS-1504041	Hex Socket Cap Screw	M8x20	4
41	TS-1515031	Hex Socket Cap Screw	M8x22	3
42	ZX-T42	Pin	10n6x22	1
43	ZX-03302	Sign Plate		1
45	ZX-T45	Nail	3x8	4
46	ZX-03105	Nut		1
47	BB-51205	Thrust Ball Bearing	25x47x15	1
48	ZX-03104	Back Cover		1
49	ZX-03103	Hand Wheel		1
50	ZX-03707	Lever		1
51	ZX-T51	Acorn Nut	M16	1
52	TS-155010	Flat Washer	M16	1
53	ZX-T53	Key	6x40	1
54	ZX-03710A	Lead Screw (for 18"/22" models)		1
	ZX-03710B	Lead Screw (for 14"/16" models)		1
55	ZX-03101A	Tailstock Casting (for 18" models)		1
	ZX-03101B	Tailstock Casting (for 16" models)		1
	ZX-03101C	Tailstock Casting (for 14" models)		1
	GH2280ZX-03101	Tailstock Casting (for 22" model)		1
56	ZX-T56	Oil Cup	8	1
57	ZX-03708	Dial		1
58	ZX-03706	Sleeve		1
59	ZX-03711C	Spring Leaf		1
65	TS-2310162	Nut	M16	1

22.0 Tailstock Assembly II – Exploded View

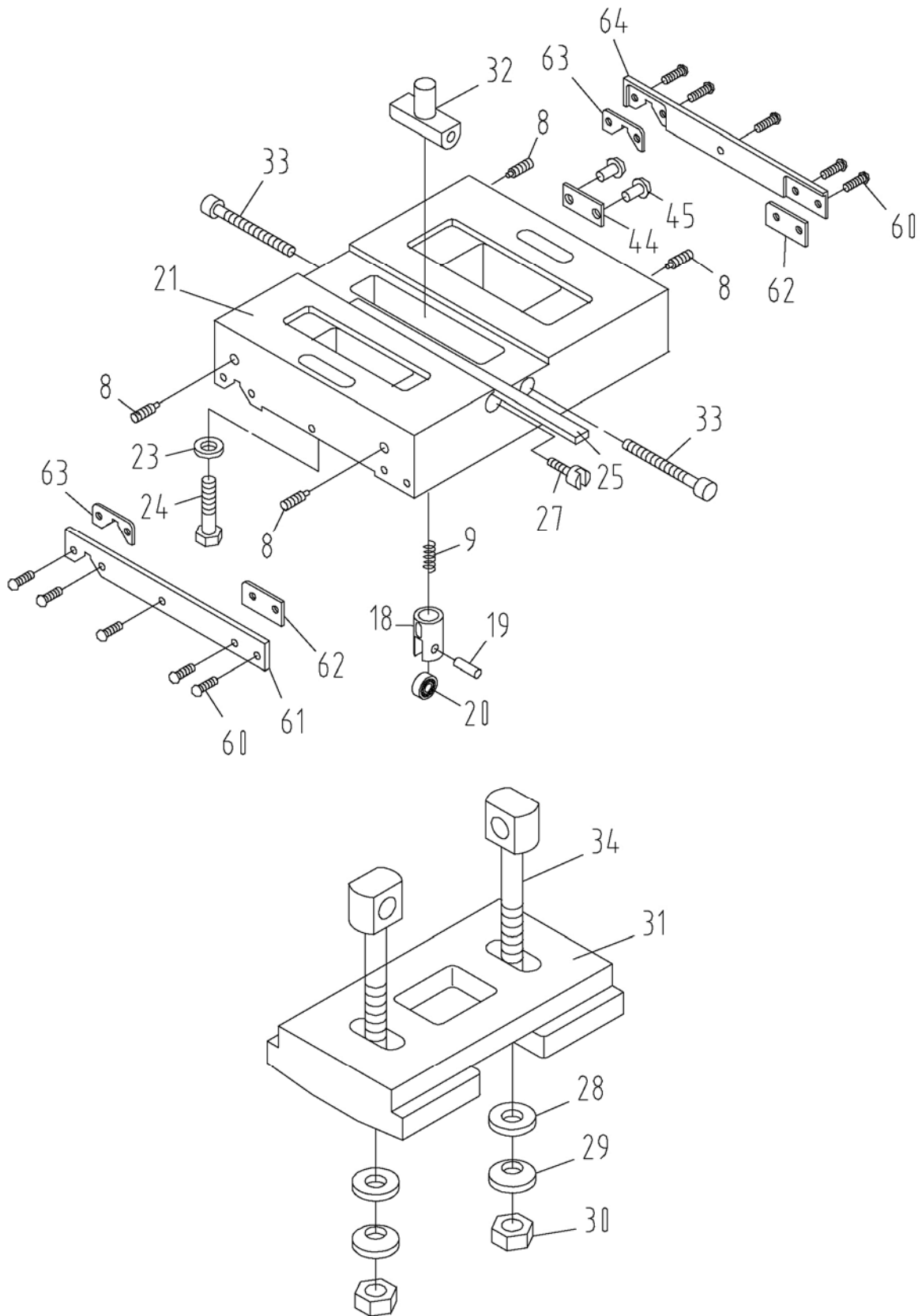

22.1 Tailstock Assembly II – Parts List

Index No	Part No	Description	Size	Qty
8	ZX-T08	Flat End Set Screw (except in 14" models)	M6x18	4
9	ZX-T09E	Spring (serial # 120120ZX2425 and higher)		1
18	ZX-03714	Bearing Support (except in 14" models)		4
19	ZX-03715	Small Axle (except in 14" models)		4
20	ZX-T20	Ball Bearing (except in 14" models)	7x19x6	4
21	ZX-03102A	Sliding Base (for 18"/22" models)		1
	ZX-03102B	Sliding Base (for 16" models)		1
	ZX-03102C	Sliding Base (for 14" models)		1
23	TS-1550071	Flat Washer	M10	2
24	TS-1491151	Hex Cap Bolt (for 18"/22" models)	M10x90	2
	TS-1491121	Hex Cap Bolt (for 16" models)	M10x70	2
	TS-1491081	Hex Cap Bolt (for 14" models)	M10x50	2
25	ZX-03704	Gib		1
26	ZX-03721C	Spherical Washer		2
27	ZX-03718C	Adjusting Screw		2
28	ZX-T28	Taper Washer	16	2
29	ZX-T29	Spherical Washer	16	2
30	TS-2310162	Hex Nut	M16	2
31	ZX-03106	Clamping Bracket		1
32	ZX-03105C	Nut		1
33	ZX-T33	Hex Socket Cap Screw	M8x85	2
34	ZX-03705A	Pulling Rod (for 18"/22" models)		2
	ZX-03705B	Pulling Rod (for 16" models)		2
	ZX-03705C	Pulling Rod (for 14" models)		2
44	ZX-03303	Sign Plate		1
45	ZX-T45	Nail	3x8	4
60	ZX-T60	Half Round Head Screw	M5 x12	10
61	ZX-03721	Plate		1
62	ZX-03502	Wipe Plate		2
63	ZX-03503	Wipe Plate		2
64	ZX-03716	Plate		1
	ZX-TSA14	Tailstock Assembly, 14" (includes # 1-13,15-64)		
	ZX-TSA16	Tailstock Assembly, 16" (includes # 1-13,15-64)		
	ZX-TSA18	Tailstock Assembly, 18" (includes # 1-13,15-64)		
	ZX-TSA22	Tailstock Assembly, 22" (includes # 1-13,15-64)		

23.0 Steady Rest Assembly – Exploded View

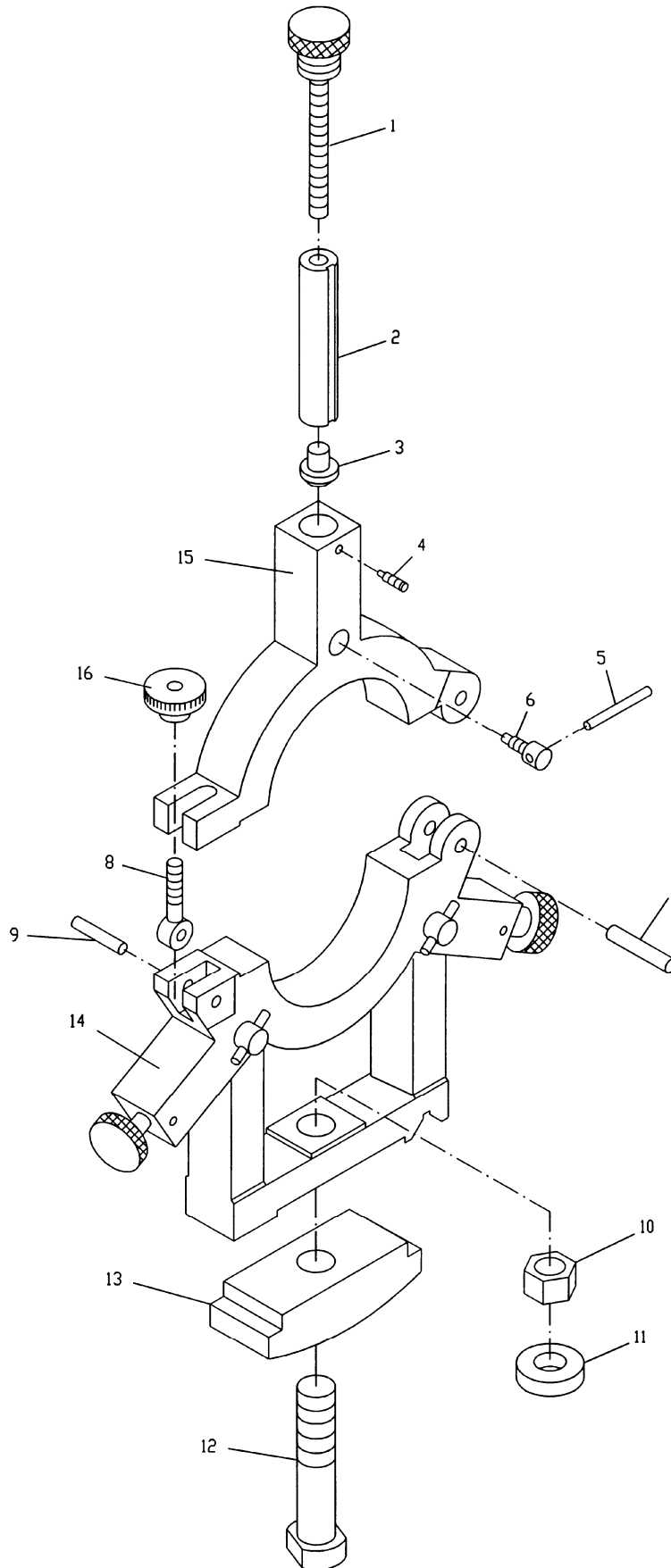

23.1 Steady Rest Assembly – Parts List

Index No	Part No	Description	Size	Qty
	ZX-SRA14	Steady Rest Assembly, 14" (includes # 1-16)		
	ZX-SRA16	Steady Rest Assembly, 16" (includes # 1-16)		
	ZX-SRA18	Steady Rest Assembly, 18" (includes # 1-16)		
	ZX-SRA22	Steady Rest Assembly, 22" (includes # 1-16)		
1	ZX-10702A	Screw (for 14" models)		3
	ZX-10702B	Screw (for 16" models)		3
	ZX-10702C	Screw (for 18"/22" models)		3
2	ZX-10704D	Sliding Sleeve	90-180	3
	ZX-10705D	Sliding Sleeve	20-210	3
3	ZX-10301D	Pushing Block		3
4	ZX-SR04	Slotted Set Screw	M6x20	3
5	ZX-10705	Lever		3
6	ZX-10706	Locking Screw		3
7	ZX-C36	Pin	10n6x40	1
8	ZX-10701D	Hinge Screw (for 14" models)		1
	ZX-10701E	Hinge Screw (for 16" models)		1
	ZX-10701F	Hinge Screw (for 18" models)		1
	ZX-10701	Hinge Screw (for 22" models)		1
9	ZX-SR9	Pin	8n6x40	1
10	ZX-SR10	Hex Nut	M20	1
11	ZX-SR11	Flat Washer	20	1
12	ZX-10708	Tightening Screw		1
13	ZX-10103D	Clamping Plate		1
14	ZX-10101D	Lower Part of Steady Rest (for 14" models)		1
	ZX-10101E	Lower Part of Steady Rest (for 16" models)		1
	ZX-10101F	Lower Part of Steady Rest (for 18" models)		1
	GH2280ZX-10101	Lower Part of Steady Rest (for 22" model)		1
15	ZX-10102D	Upper Part of Steady Rest (for 14" models)		1
	ZX-10102E	Upper Part of Steady Rest (for 16" models)		1
	ZX-10102F	Upper Part of Steady Rest (for 18" models)		1
	ZX-10102	Upper Part of Steady Rest (for 22" model)		1
16	ZX-SR16	Round Nut	M10	1

24.0 Follow Rest Assembly – Exploded View

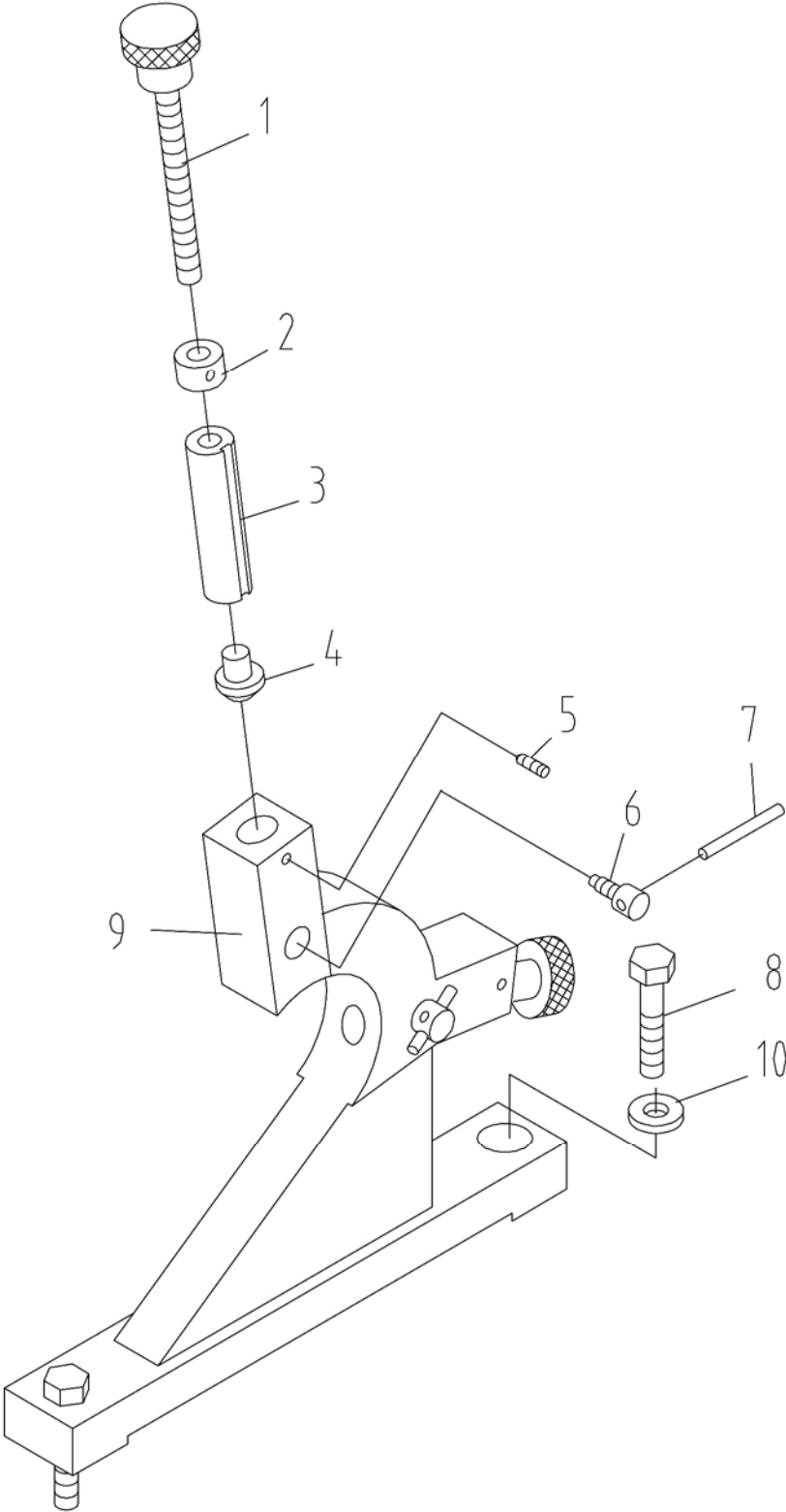

24.1 Follow Rest Assembly – Parts List

Index No	Part No	Description	Size	Qty
	ZX-FRA14	Follow Rest Assembly, 14" (includes #1-7,9)		
	ZX-FRA16	Follow Rest Assembly, 16" (includes #1-7,9)		
	ZX-FRA18	Follow Rest Assembly, 18" (includes #1-7,9)		
	ZX-FRA22	Follow Rest Assembly, 22" (includes #1-7,9)		
1	ZX-10710	Screw		2
2	ZX-10704	Nut		2
3	ZX-10707	Sliding Sleeve		2
4	ZX-10301	Supporting Piece		2
5	ZX-FR05	Slotted Set Screw	M6x10	2
6	ZX-10705	Locking Screw		2
7	ZX-10706	Handle		2
8	ZX-FR8	Hex Cap Bolt	M12x55	2
9	ZX-10102A	Follow Rest Casting (for 14" models)		1
	ZX-10102B	Follow Rest Casting (for 16" models)		1
	ZX-10102C	Follow Rest Casting (for 18" models)		1
	GH2280ZX-10102	Follow Rest Casting (for 22" model)		1
10	ZX-FR10	Flat Washer	M12	2

25.0 Coolant & Work Light Assembly – Exploded View

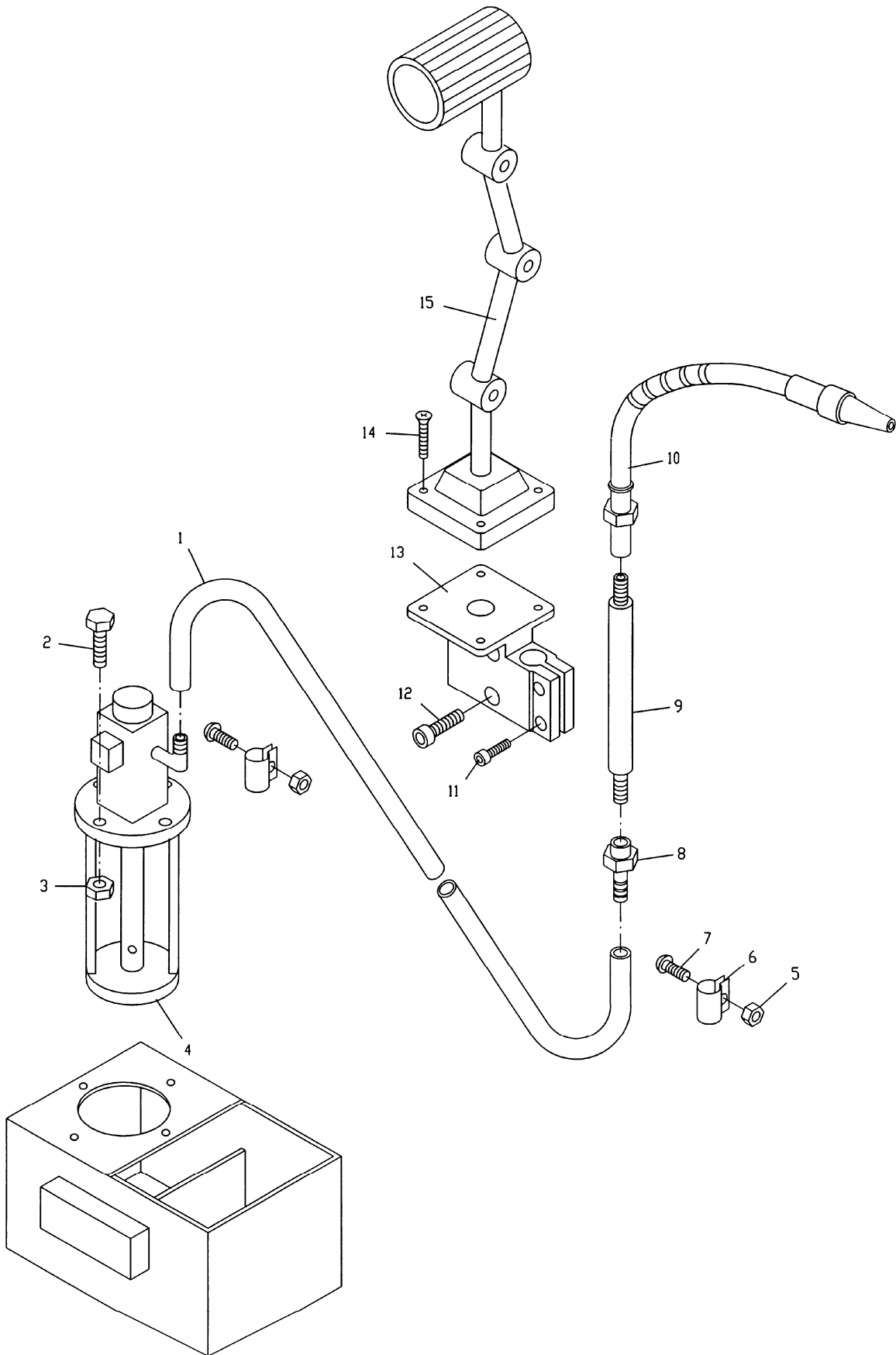

25.1 Coolant & Work Light Assembly – Parts List

Index No	Part No	Description	Size	Qty
1	RT-001A	Rubber Tube (for 1440/1640/1840ZX)	ID 1/2"x1280mm	1
	RT-001B	Rubber Tube (for 1460/1660/1860ZX)	ID 1/2"x1780mm	1
	RT-001C	Rubber Tube (for 1880/2280ZX)	ID 1/2"x2280mm	1
2	ZX-CW02	Hex Cap Bolt	M5x25	4
3	ZX-CW03	Hex Nut	5	4
4	ZX-CW04	Coolant Pump		1
5	ZX-CW05	Hex Nut	M6	2
6	ZX-01727	Clip For Rubber Tube		2
7	ZX-CW07	Half Round Head Screw	M6x16	2
8	ZX-01728	Fitting		1
9	ZX-01729	Flow Pipe		1
10	ZX-CW10	Coolant Device		1
	ZX-CW10-1	Coolant Tap	G 3/8"	1
11	TS-1514021	Hex Socket Cap Screw	M6x16	2
12	TS-1515051	Hex Socket Cap Screw	M8x40	2
13	ZX-CW13	Lamp Support		1
14	ZX-S04	Cross Head Screw	M6x14	4
15	ZX-CW15	Lamp Frame		1
	ZX-CW16	Bulb (not shown)	50W, AC24V	1
	ZX-CW17	Lens (not shown)		1
	ZX-LA	Light Assembly (includes # 13-17)		
16	ZX-WLCP01	Tube (for 40" models)	1.7m	1
	ZX-WLCP02	Tube (for 60" models)	2.2m	1
	ZX-WLCP03	Tube (for 80" models)	2.7m	1

26.0 Chuck Guard Assembly – Exploded View

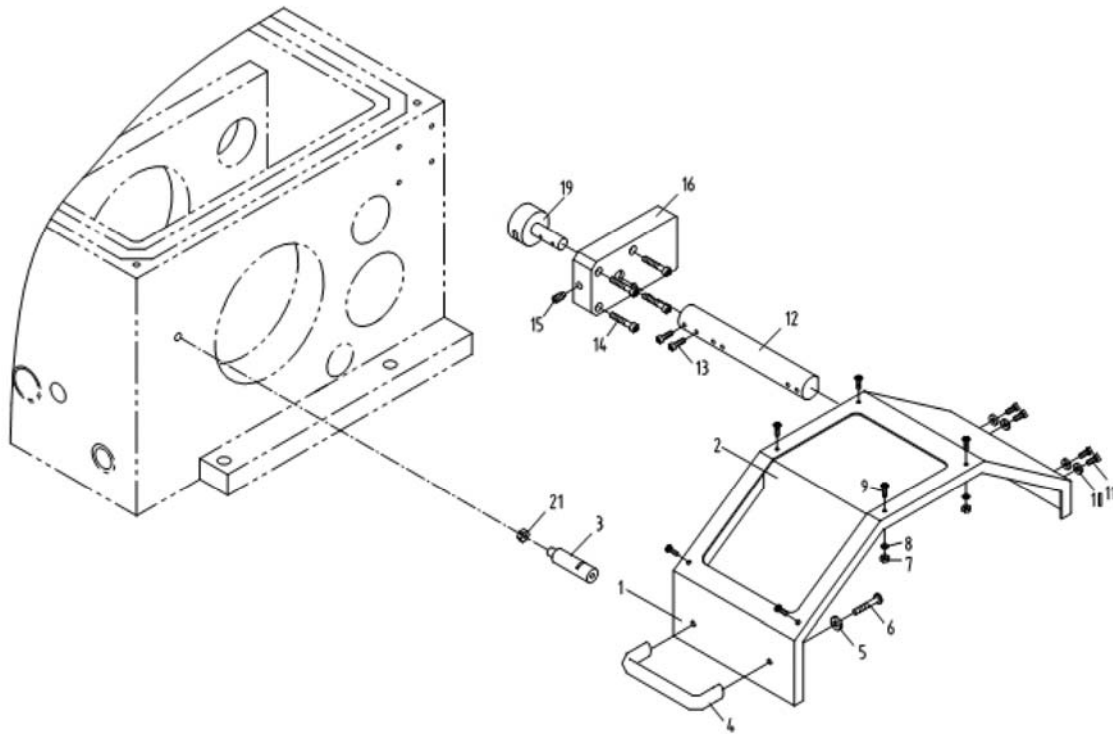

26.1 Chuck Guard Assembly – Parts List

Index No	Part No	Description	Size	Qty
	ZX-CGA	Chuck Guard Assembly (includes #1-21)		1
1	ZX-19701E	Protection Guard		1
2	ZX-19501E	Protection Guard Visual Glass		1
3	ZX-19704E	Fixing Rod		1
4	ZX-S04E	Handle	Z96-6	1
5	ZX-S05E	Plain Washer	6mm	2
6	ZX-S06E	Cross Recessed Pan Head Screw	M6x12	2
7	ZX-S07E	Hexagon Thin Nut	M4	6
8	TS-1550021	Plain Washer	4 mm	6
9	TS-1532042	Cross Recessed Pan Head Screw	M4x12	6
10	TS-1550031	Plain Washer	5 mm	4
11	TS-1502041	Hex Socket Cap Screw	M5x16	4
12	ZX-19703E	Rest Bar		1
13	ZX-S13E	Slotted Set Screw	M8x10	2
14	TS-1503081	Hex Socket Head Cap Screw	M6x35	4
15	TS-1524041	Hexagon Socket Set Screw	M8x16	1
16	GH1440A-19101E	Switch box		1
19	ZX-19702E	Shaft		1
21	ZX-S21E	Nut	M8	1

NOTE: This device is installed from serial # 110825ZX2338.

27.0 Other Parts

Index No	Part No	Description	Size	Qty
1A	ZX-OP-1A	3-Jaw Chuck (mounted on lathe – not shown)	10", D1-8	1
1B	ZX-OP-1B	Chuck Wrench		1
2A	ZX-OP-2A	4-Jaw Chuck	12", D1-8	1
2B	ZX-OP-2B	Chuck Wrench		1
3	ZX-OP-03	12" Face Plate (for 14"/16" models)		1
	ZX-OP-03N	16" Face Plate (for 18"/22" models)		1
4	ZX-OP-04	Tool Tightening Wrench		1
5	ZX-OP-05	Cam Tightening Wrench		1
6	ZX-OP-06	Center		1
7	ZX-OP-07	MT-4 Live Center (for 14"/16" models)		1
	ZX-OP-07N	MT-5 Live Center (for 18"/22" models)		1
8	ZX-OP-08	Morse Reduction Sleeve		1
9	ZX-OP-09	Oil Gun		1
10	ZX-OP-10	Touchup Paint Can (JET white)		1
11	ZX-OP-11	Gap Bridge Pin Driver		1
12	ZX-OP-12	Hex Wrench Set	2.5,4,5,6,8,10	1 set
13	ZX-OP-13	Open End Wrench Set		1 set
14	ZX-OP-14	Flat Blade Screw Driver		1
15	ZX-OP-15	Cross Point Screw Driver		1
16	ZX-OP-16	Adjustable Wrench		1
17	ZX-OP-17	Round Nut Wrench		1
18	ZX-OP-18	Shear Pin		2
19	ZX-OP-19	Fuse	2A	3
20	ZX-OP-20	Fuse	3A	2
21	ZX-OP-21	Indicator Bulb	110V or 24V	1
22	ZX-OP-22	Taper Piece		1
23	ZX-OP-23	Gear	3.5m36T(14"/16" /22")	1
	ZX-OP-23	Gear	4m36T(18")	1
24	ZX-01712	Leveling Bolt		6
25	ZX-01715	Leveling Pad		6
26	TS-1540231	Hex Nut	M24-2	6
	ZX-18TBPCP	Tool Box Complete (not shown)	ZX-18"	

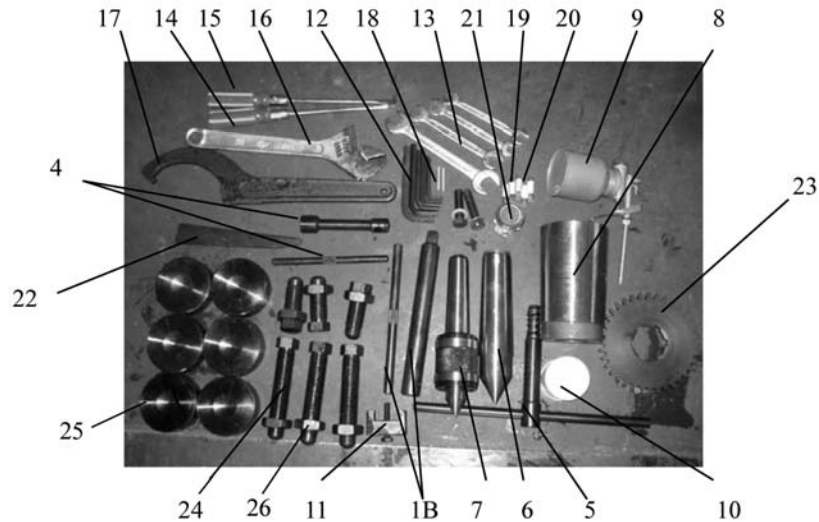
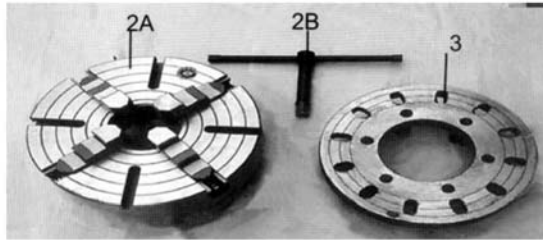

28.0 Electrical Cabinet – Parts List

Index No.	Part No.	Description	Size	Qty.
1	ZX-SB1	Jog Button	LAY3-11	1
2	ZX-SA2	Coolant Control Button	LAY3-11X/2	1
3	ZX-SB2	Emergency Stop	LAY3-012S/1	1
4	ZX-HL	Power Indicator Light	XD11-30/20	1
5	ZX-SA3	Rotary Switch	HZ3-452	1
6	ZX-QF	Master Switch Circuit Breaker (40A)	DZ15-40/390	1
6A	ZX-QF-1	Door Lock Switch		1
7	ZX-FU1	Fuse (3A)	JRT1-16A	1
8	ZX-FU2	Fuse (2A)	JRT1-16A	1
9	ZX-FU3	Fuse (2A)	JRT1-16A	1
10	ZX-FU5	Fuse (2A)	JRT1-16A	1
	ZX-FB	Fuse Block		1
11	ZX-Q	Temperature Relay	JW6	1
12	ZX-KM2	A.C. Contactor	3TB40	1
13	ZX-KA	A.C. Contactor	3TB80	1
14	ZX-KM3	A.C. Contactor (for 14,16,18" models)	3TB43	1
	GH-2280ZX-KM3	A.C. Contactor (for 22" models)	3TB44	1
15	ZX-KM4	A.C. Contactor (for 14,16,18" models)	3TB43	1
	GH-2280ZX-KM4	A.C. Contactor (for 22" models)	3TB44	1
16	ZX-XB	Copper Plate (for grounding)		1
17	ZX-XT1	Wiring Board	JT1	1
18	ZX-XT2	Wiring Board	JX0	1
19	ZX-TC	Control Transformer	JBK3-100-TH	1
20	ZX-SQ2	Stroke Switch	LXW5-11N1	1

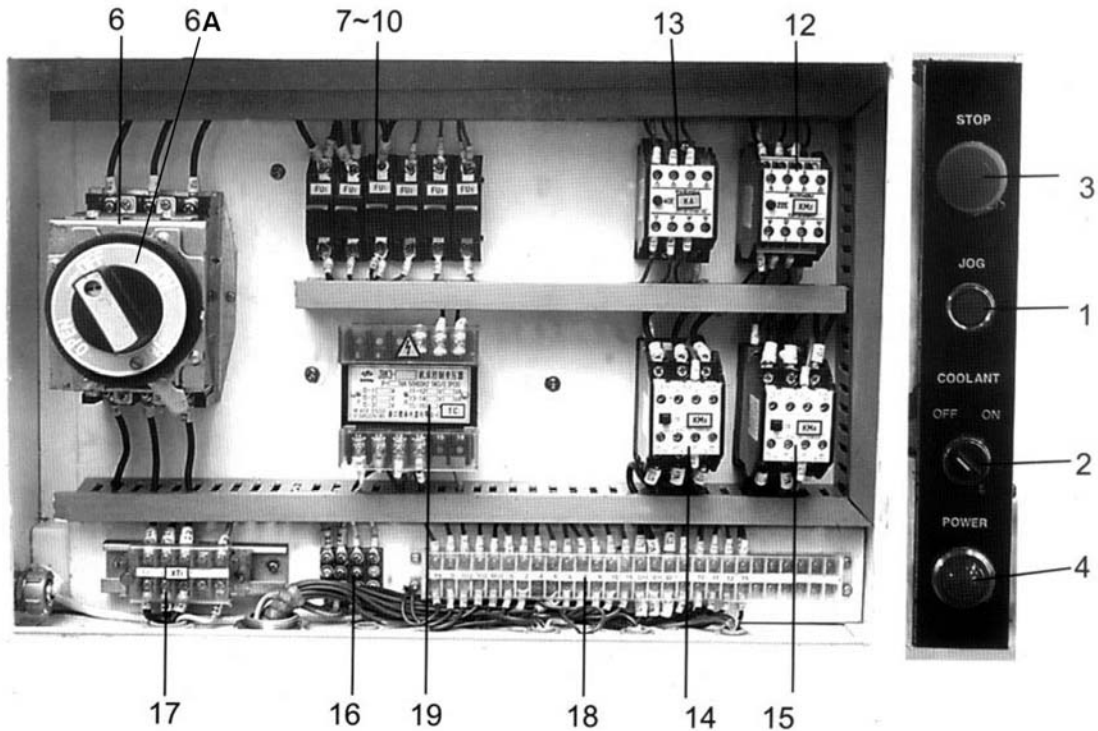

29.0 Wiring Diagram

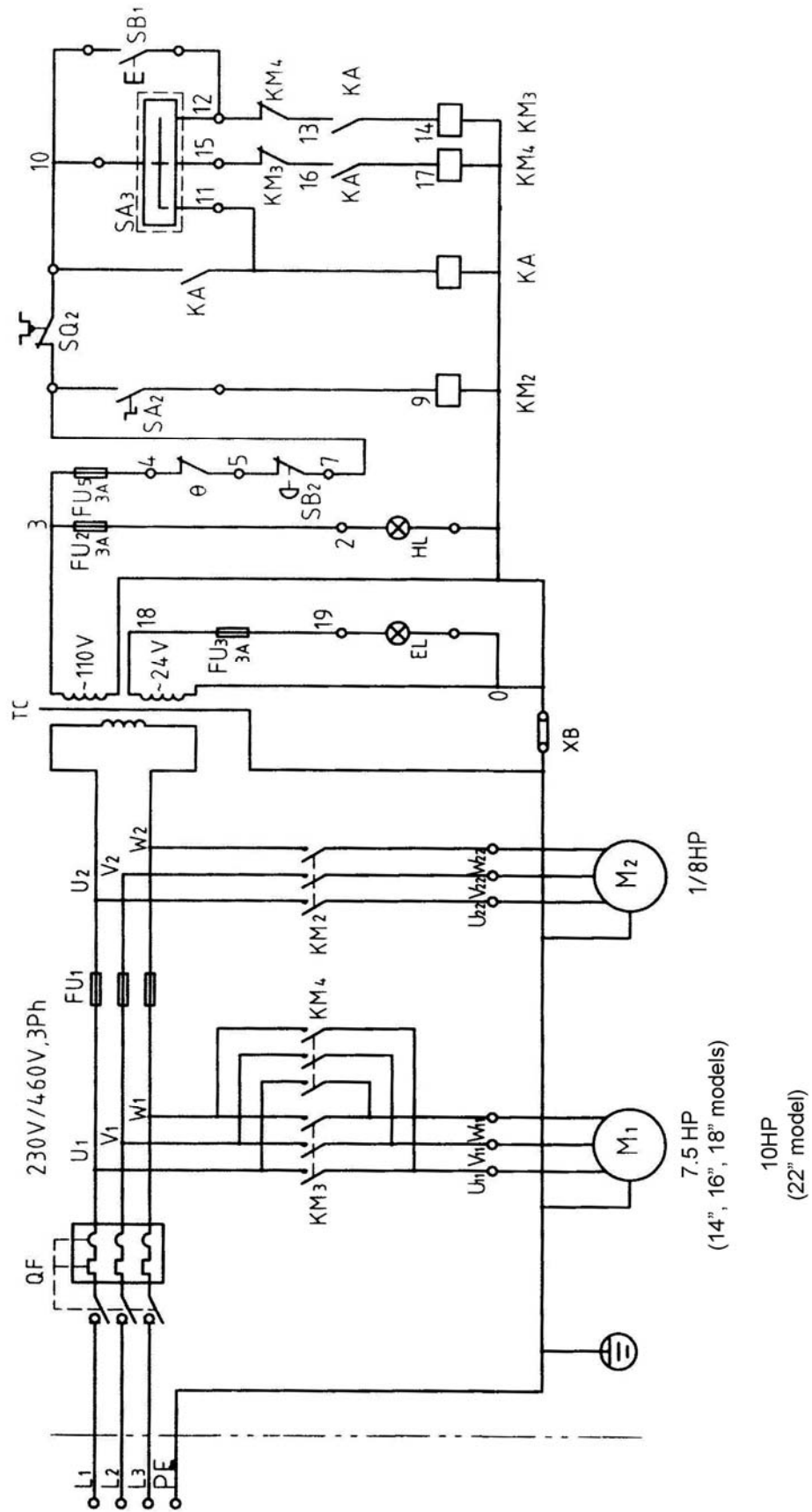

30.0 Rotary Switch Diagram

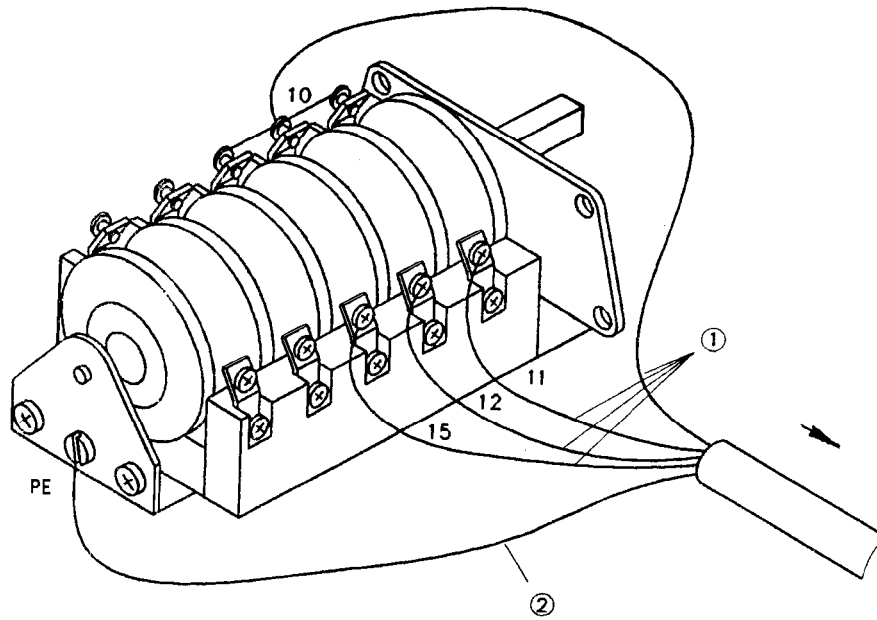

1.....The Cord from the Wiring Board (part no. ZX-XT2)

2.....The Grounding Wire from the Copper Plate (part no. ZX-XB)

This page intentionally left blank



427 New Sanford Road
LaVergne, Tennessee 37086
Phone: 800-274-6848
www.jettools.com