

SOUTHLAND[®]

ILLUSTRATED PARTS BOOK

43cc Wheeled String Trimmer Mower SWSTM4317



Table of Contents

Unit Assembly.....	2
Engine-Top Level.....	3
Handle Assembly.....	4
Lower Weldment Assembly.....	5
Upper Weldment Assembly.....	6
Cutting Head Assembly.....	7
Engine Sub-Assemblies:	
Air Filter Assembly.....	8
Carburetor Assembly.....	9
Muffler Assembly.....	10
Fuel Tank Assembly.....	11
Clutch Assembly.....	12
Recoil Starter Assembly.....	13
Cylinder Assembly.....	14
Ignition Assembly.....	15
Air Cooling Assembly.....	16
Engine Air Intake Screen Assembly.....	17
Decal Kit.....	18

Unit Assembly

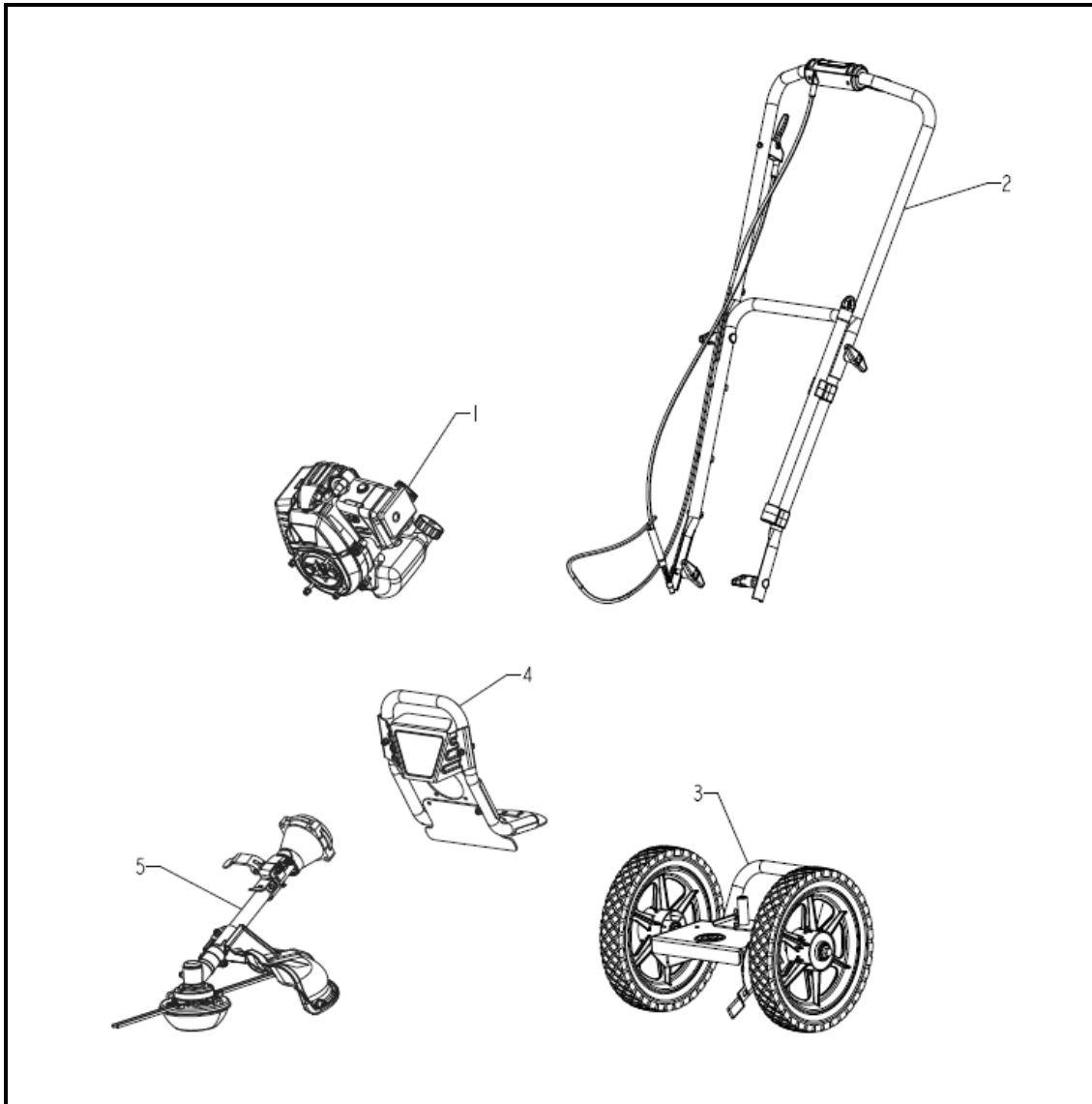

REF. NO.	DESCRIPTION	PART NO.	QTY
1	Engine-Top Level	See Page 3	1
2	Handle Assembly	See Page 4	1
3	Lower Weldment Assembly	See Page 5	1
4	Upper Weldment Assembly	See Page 6	1
5	Cutting Head Assembly	See Page 7	1

Engine-Top Level

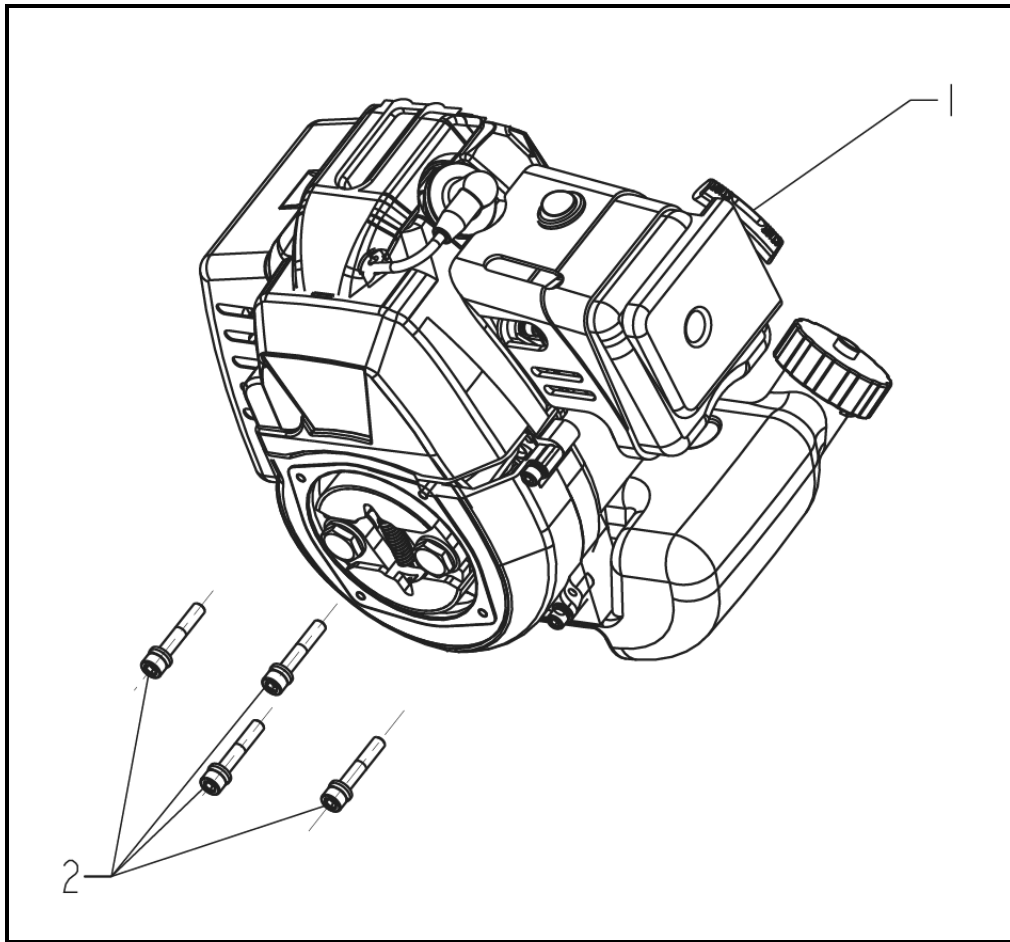

REF. NO.	DESCRIPTION	PART NO.	QTY
1	Engine, 43cc	A203550	1
2	Screw, M6 x 1.0 x 35, SHCS, Grade 8.8	<i>Reference Only</i>	4

Handle Assembly

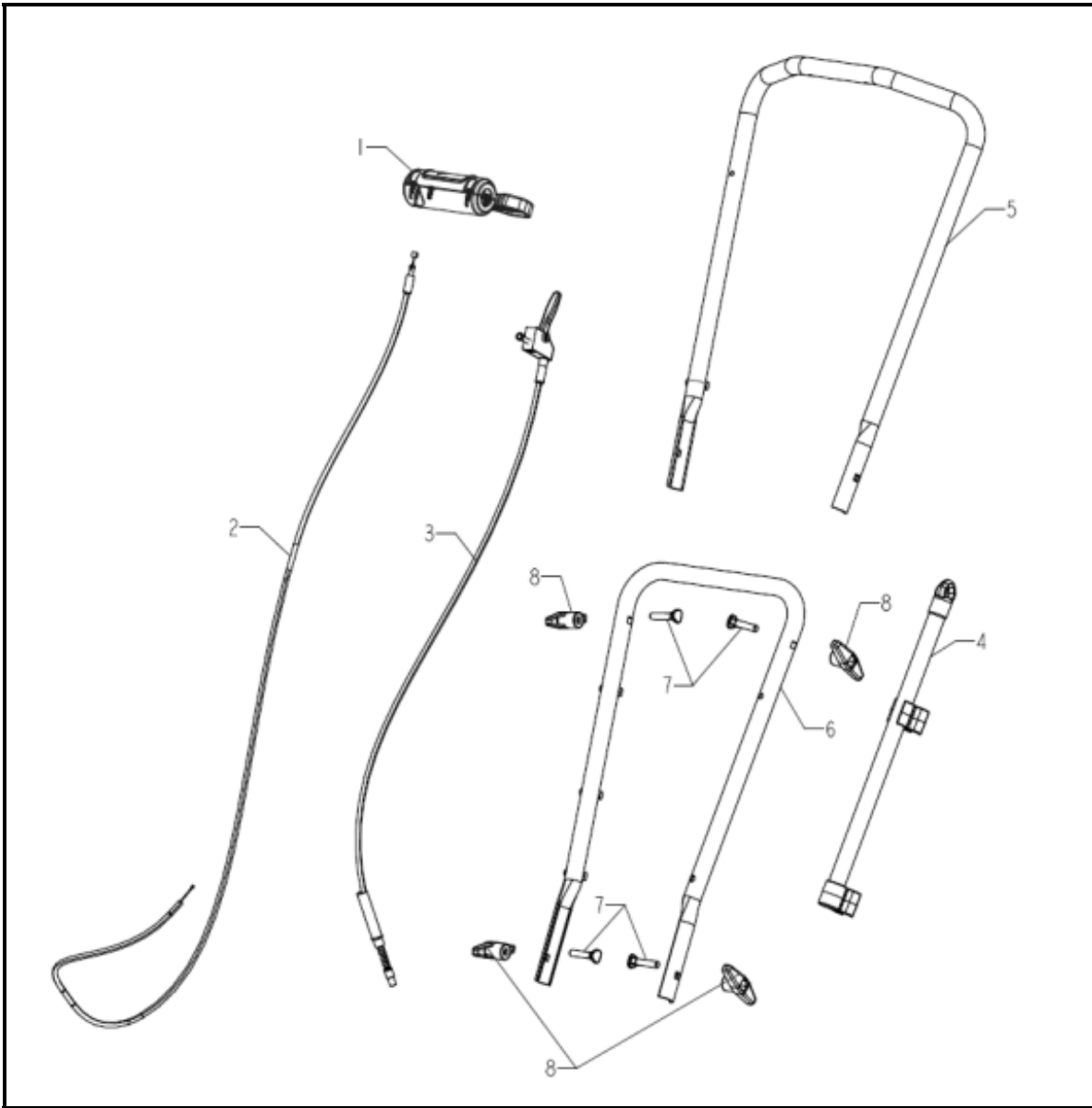

REF. NO.	DESCRIPTION	PART NO.	QTY
1	Kit, Throttle Assembly	A203628	1
2	Cable, Throttle	A203603	1
3	Kit, Pivot Trigger	A203629	1
4	Kit, Spare String Storage	A203630	1
5	Handle, Upper	A203595	1
6	Handle, Middle	A203594	1
7	Bolt, M8 x 1.25 x 45, Saddle	<i>Reference Only</i>	4
8	Knob, Handle	A200190	4

Lower Weldment Assembly

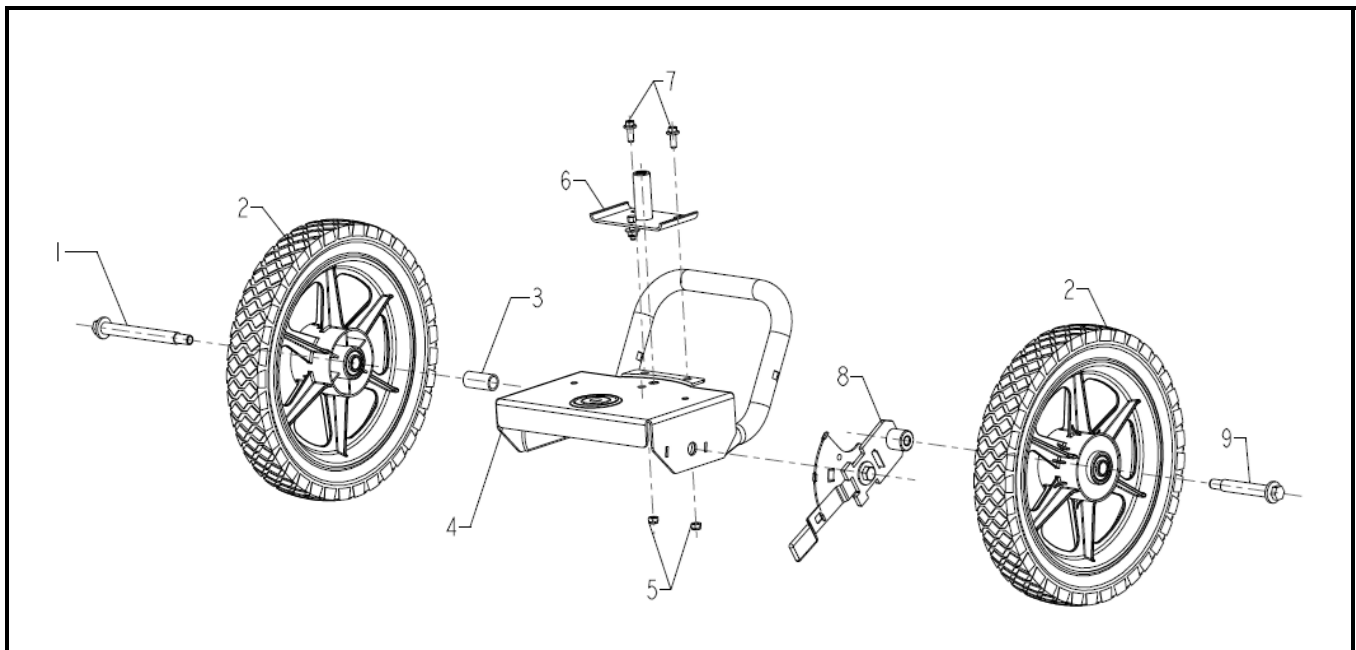

REF. NO.	DESCRIPTION	PART NO.	QTY
1	Bolt, M10 x 1.5 x 120, Right Shoulder	A203576	1
2	Wheel	A200158	2
3	Bushing	A203574	1
4	Weldment, Lower Frame	A203571	1
5	Nut, M6 x 1.0	<i>Reference Only</i>	2
6	Plate, Pivot Engagement	A203578	1
7	Bolt, M6 x 1.0 x 16, HFH, Grade 8.8	<i>Reference Only</i>	2
8	Assembly, Wheel Adjuster Bevel	A203584	1
9	Bolt, M10 x 1.5 x 85, Left Shoulder	A203632	1

Upper Weldment Assembly

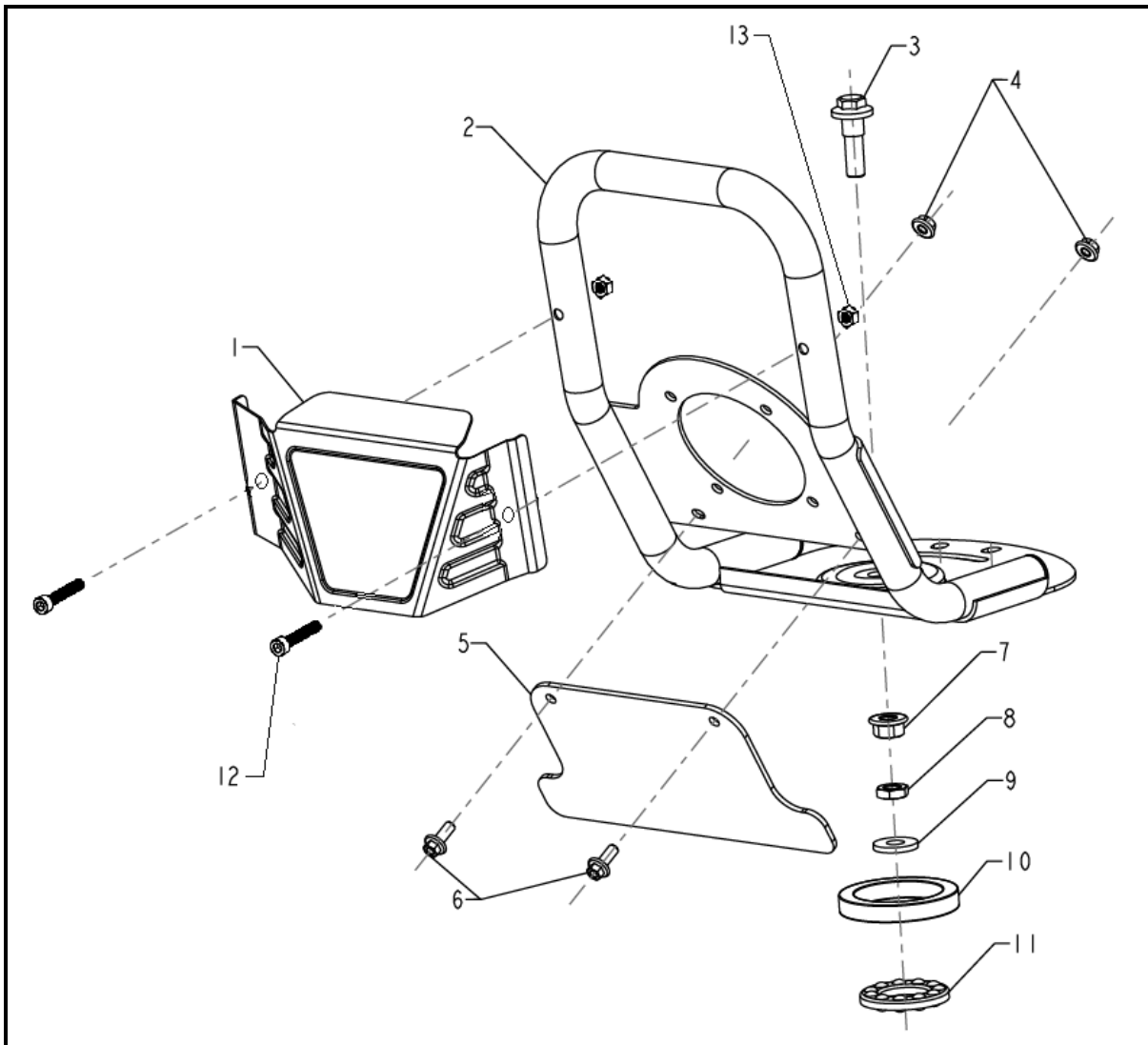

REF. NO.	DESCRIPTION	PART NO.	QTY
1	Plate, Front Decal, Southland Red	A203565	1
2	Weldment, Upper Frame	A203562	1
3	Bolt, M10 x 1.5 x 32, HFH Shoulder	Reference Only	1
4	Nut, M6 x 1.0	Reference Only	2
5	Flap, Guard	A203680	1
6	Bolt, M6 x 1.0 x 16, HFH, Grade 8.8	Reference Only	2
7	Nut, M10 x 1.5, HFH	Reference Only	1
8	Nut, M10 x 1.5	Reference Only	1
9	Flat Washer, M10	Reference Only	1
10	Seal, Felt	Reference Only	2
11	Cage, Bearing	Reference Only	1
12	Bolt, M6 x 1.0 x 35, SHCS, Grade 8.8	Reference Only	2
13	Nut, M6 x 1.0	Reference Only	2

Cutting Head Assembly

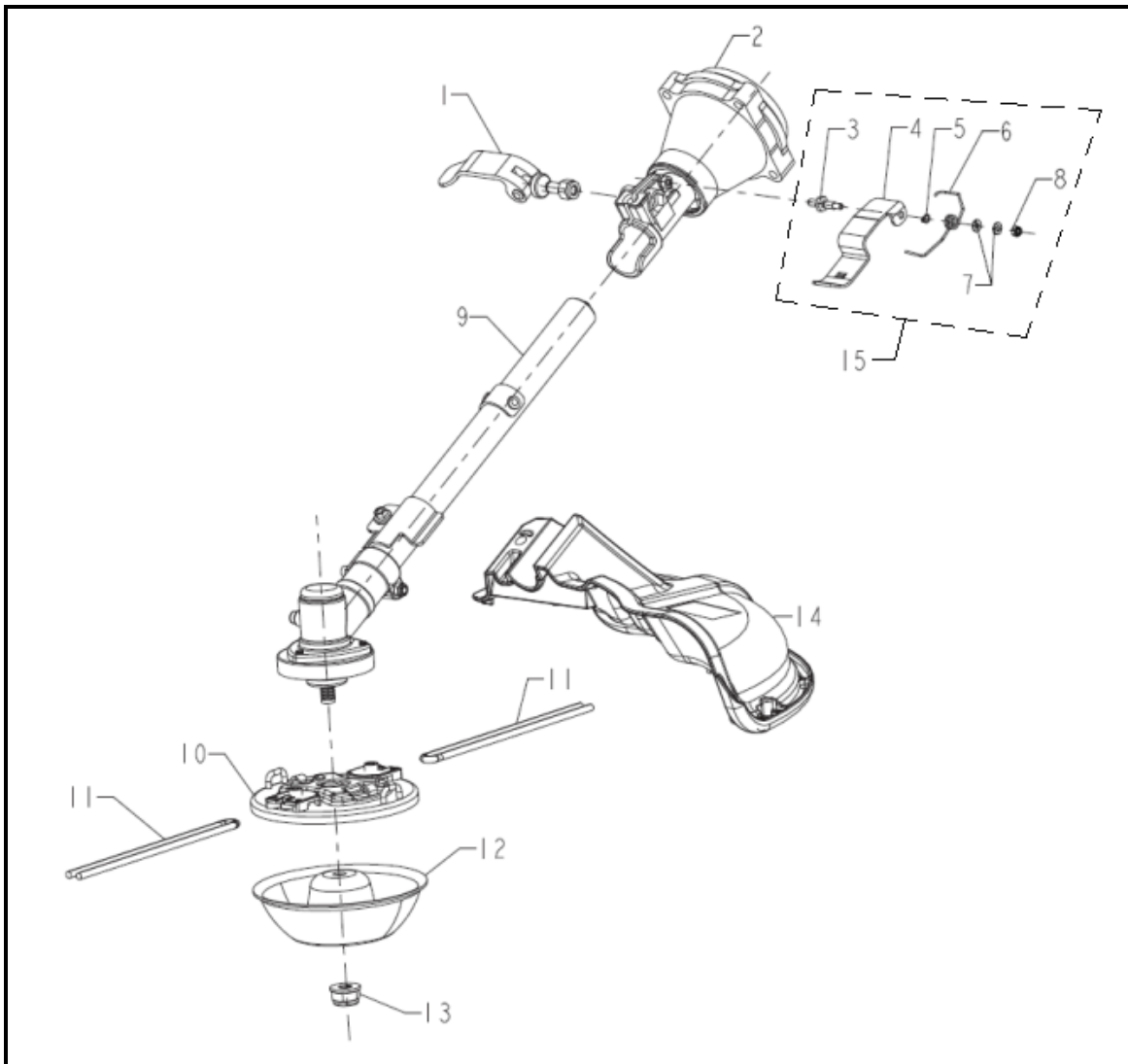

REF. NO.	DESCRIPTION	PART NO.	QTY
1	Assembly, Cam Lock	A203551	1
2	Kit, Upper Drive Housing Assembly	A203633	1
3	Shaft, Torsion Spring	<i>Reference Only</i>	1
4	Latch	A203552	1
5	Ring, Retaining	<i>Reference Only</i>	1
6	Spring, Torsion	<i>Reference Only</i>	1
7	Flat Washer, M4	<i>Reference Only</i>	2
8	Nut, M4	<i>Reference Only</i>	1
9	Kit, Cutting Head Assembly	A203634	1
10	Kit, String Retention, Southland Red	A203637	1
11	String, Trimmer	<i>Reference Only</i>	2
12	Bowl, Cutting Head, Southland Red	A203636	1
13	Nut, M10 x 1.25, LH	A203638	1
14	Kit, Debris Guard	A203635	1
15	Kit, Latch (Includes items #3-8)	A203681	1

Air Filter Assembly

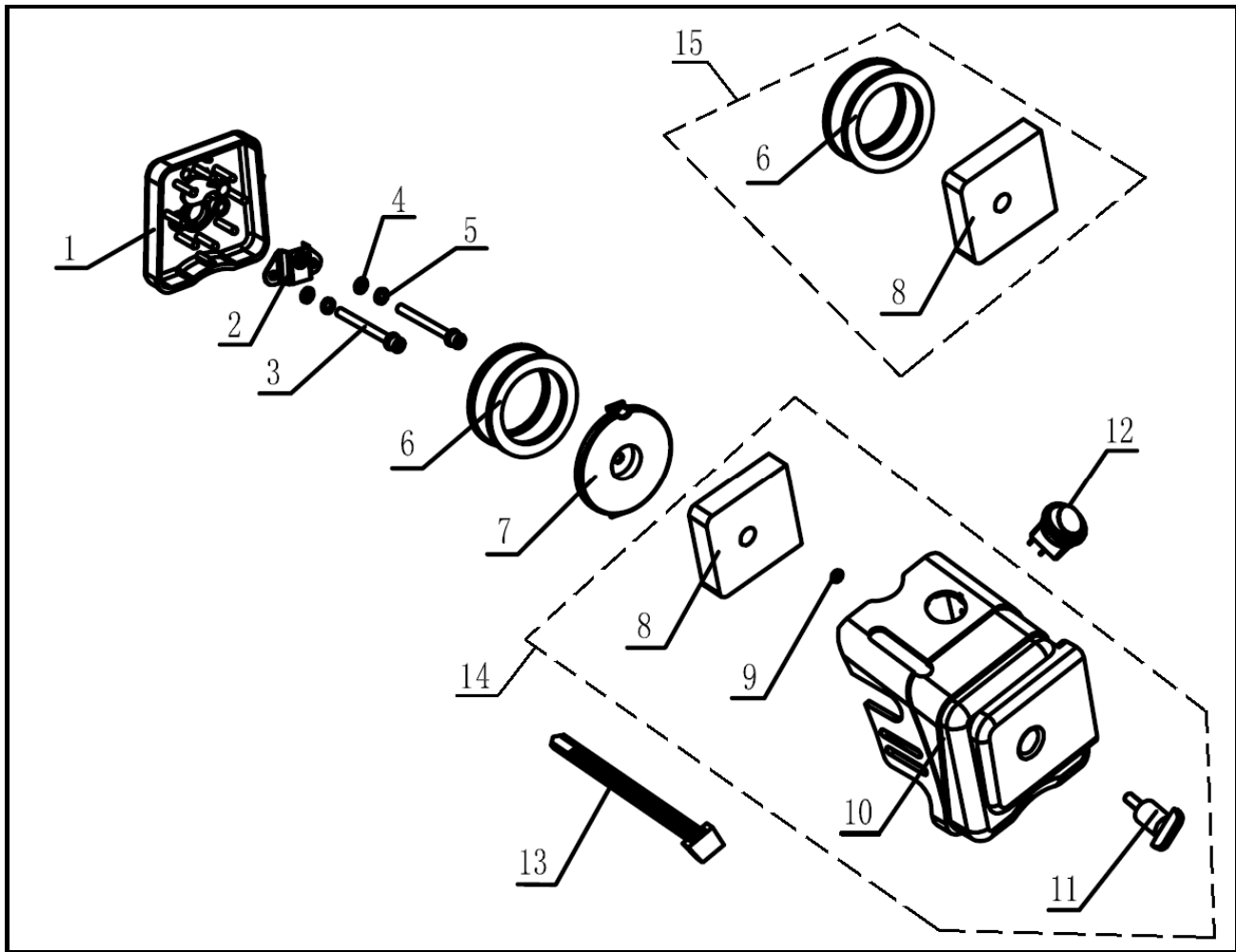

REF. NO.	DESCRIPTION	PART NO.	QTY
1	Housing, Air Filter	A200832	1
2	Bracket, Air Filter Mounting	A203644	1
3	Screw, M5 x 0.8 x 55, SHCS, Grade 8.8	Reference Only	2
4	Flat Washer, M5	Reference Only	2
5	Lock Washer, M5	Reference Only	2
6	Foam Element, Filter	Reference Only	1
7	Mounting Plate, Air Filter	A200836	1
8	Foam Element, Filter	Reference Only	1
9	O-Ring, 3.15 x 1.8	Reference Only	1
10	Cover, Air Filter	Reference Only	1
11	Knob, Screw	Reference Only	1
12	Switch, On/Off	A203060	1
13	Cable Tie	Reference Only	1
14	Kit, Air Filter Cover with Filter (Includes items #8-11)	A203642	1
15	Kit, Filters (Includes items #6 & 8)	A203643	1

Carburetor Assembly

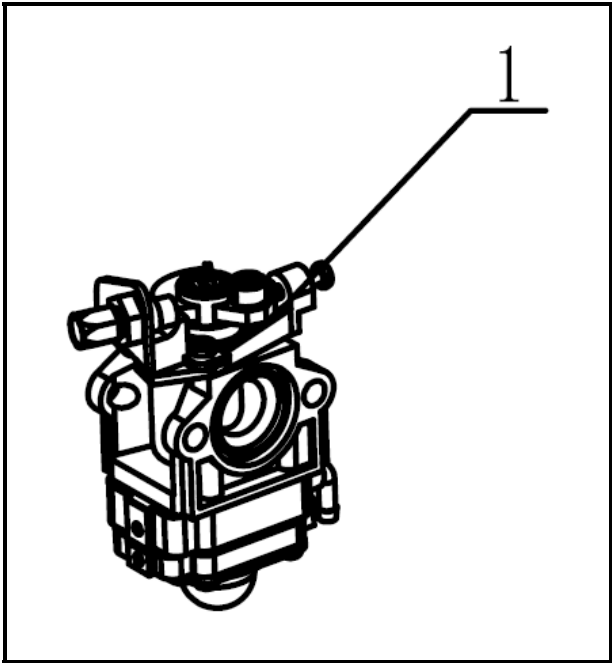

REF. NO.	DESCRIPTION	PART NO.	QTY
1	Carburetor	A200774	1

Muffler Assembly

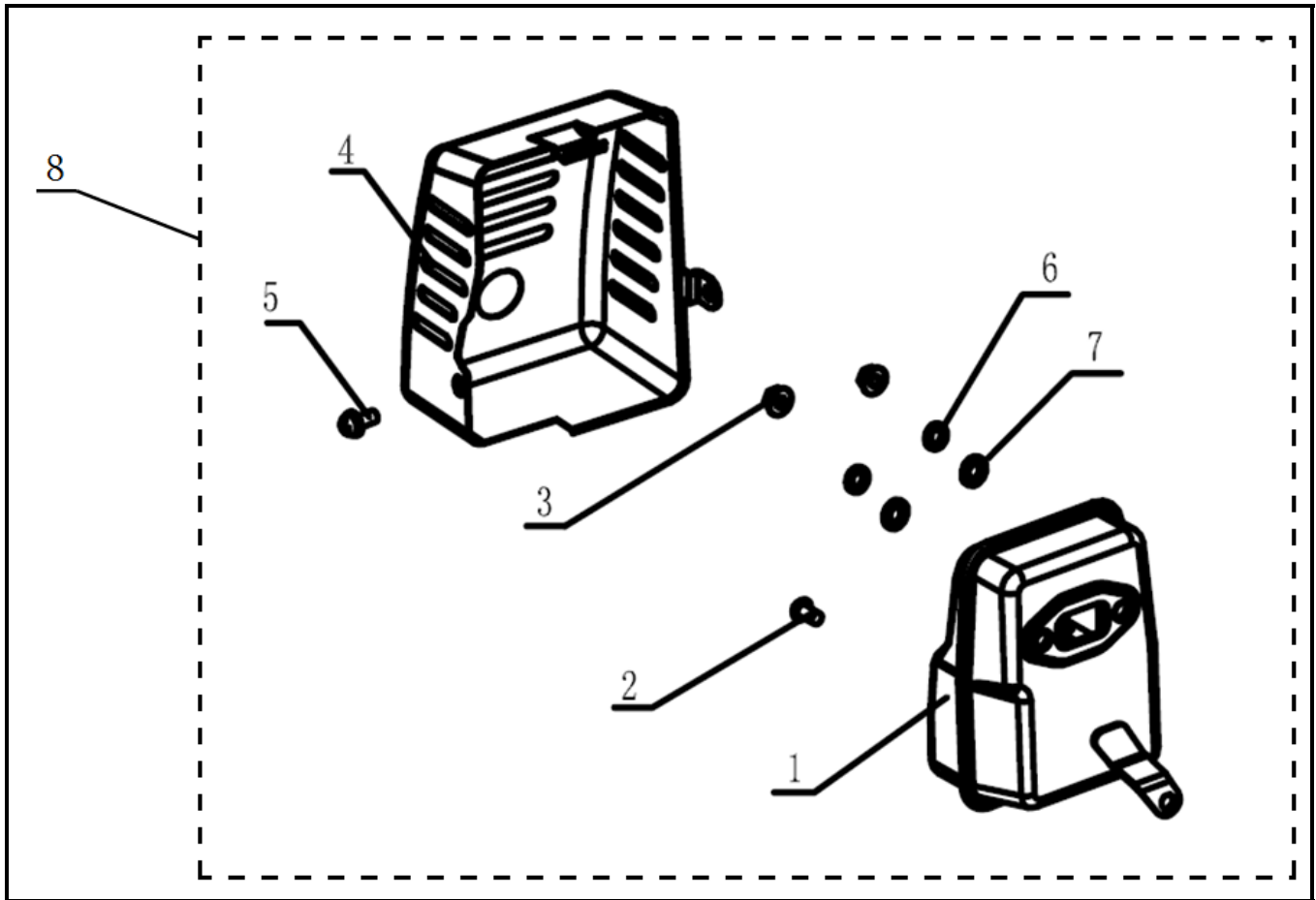

REF. NO.	DESCRIPTION	PART NO.	QTY
1	Muffler	<i>Reference Only</i>	1
2	Screw, M5 x 0.8 x 10, PHPD	<i>Reference Only</i>	1
3	Nut, M6 x 1.0	<i>Reference Only</i>	2
4	Cover, Muffler	A200844	1
5	Screw, M5 x 0.8 x 12, PHPD	<i>Reference Only</i>	1
6	Lock Washer, M6	<i>Reference Only</i>	2
7	Flat Washer, M6	<i>Reference Only</i>	2
8	Muffler Assembly (Includes items #1-7)	A200775	1

Fuel Tank Assembly

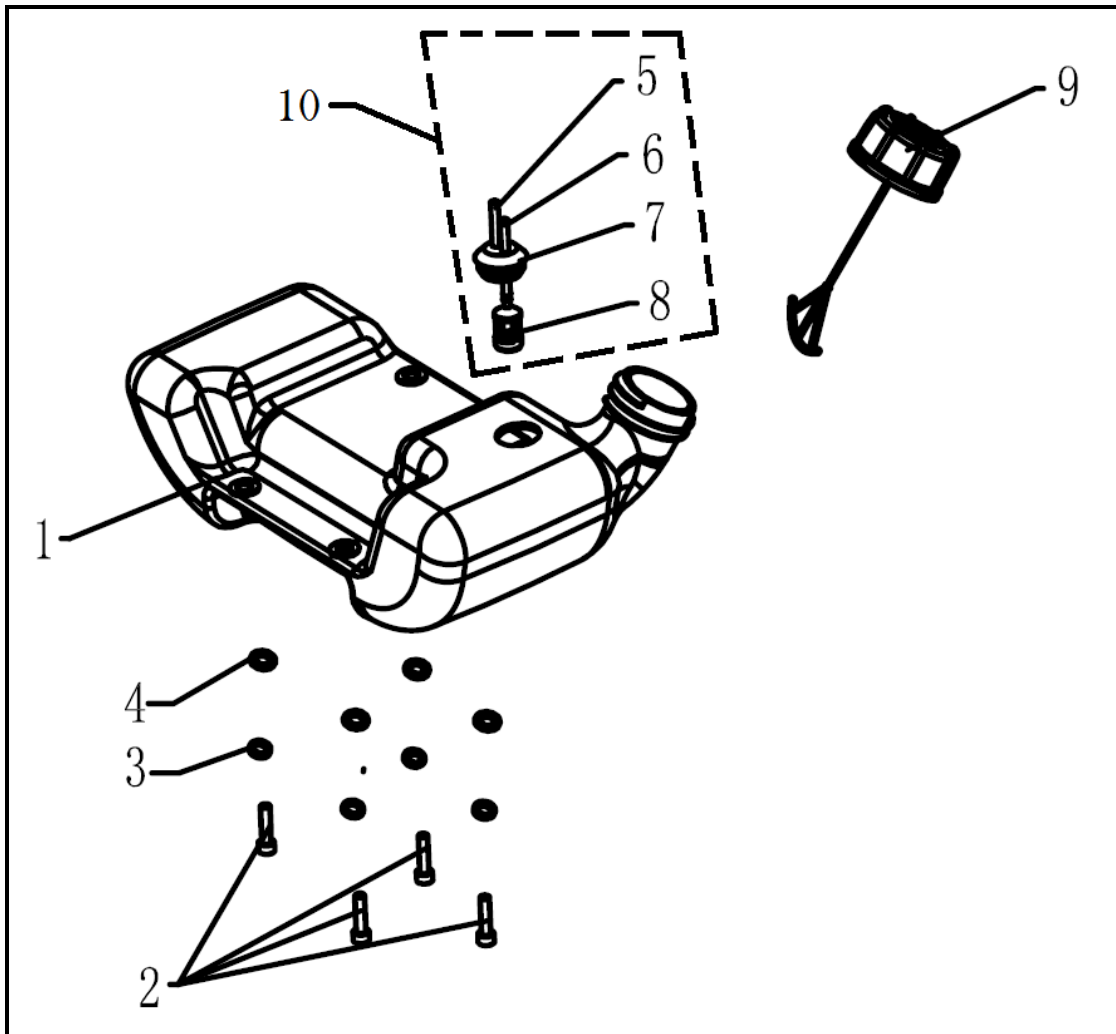

REF. NO.	DESCRIPTION	PART NO.	QTY
1	Tank, Fuel	A203640	1
2	Screw, M5 x 0.8 x 18, SHCS, Grade 8.8	Reference Only	4
3	Lock Washer, M5	Reference Only	4
4	Flat Washer, M5	Reference Only	4
5	Fuel Line 1	Reference Only	1
6	Fuel Line 2	Reference Only	1
7	Seal, Fuel Lines	Reference Only	1
8	Filter, Fuel	Reference Only	1
9	Cap, Fuel	A200781	1
10	Kit, Fuel Line/Filter (Includes items #5-8)	A203641	1

Clutch Assembly

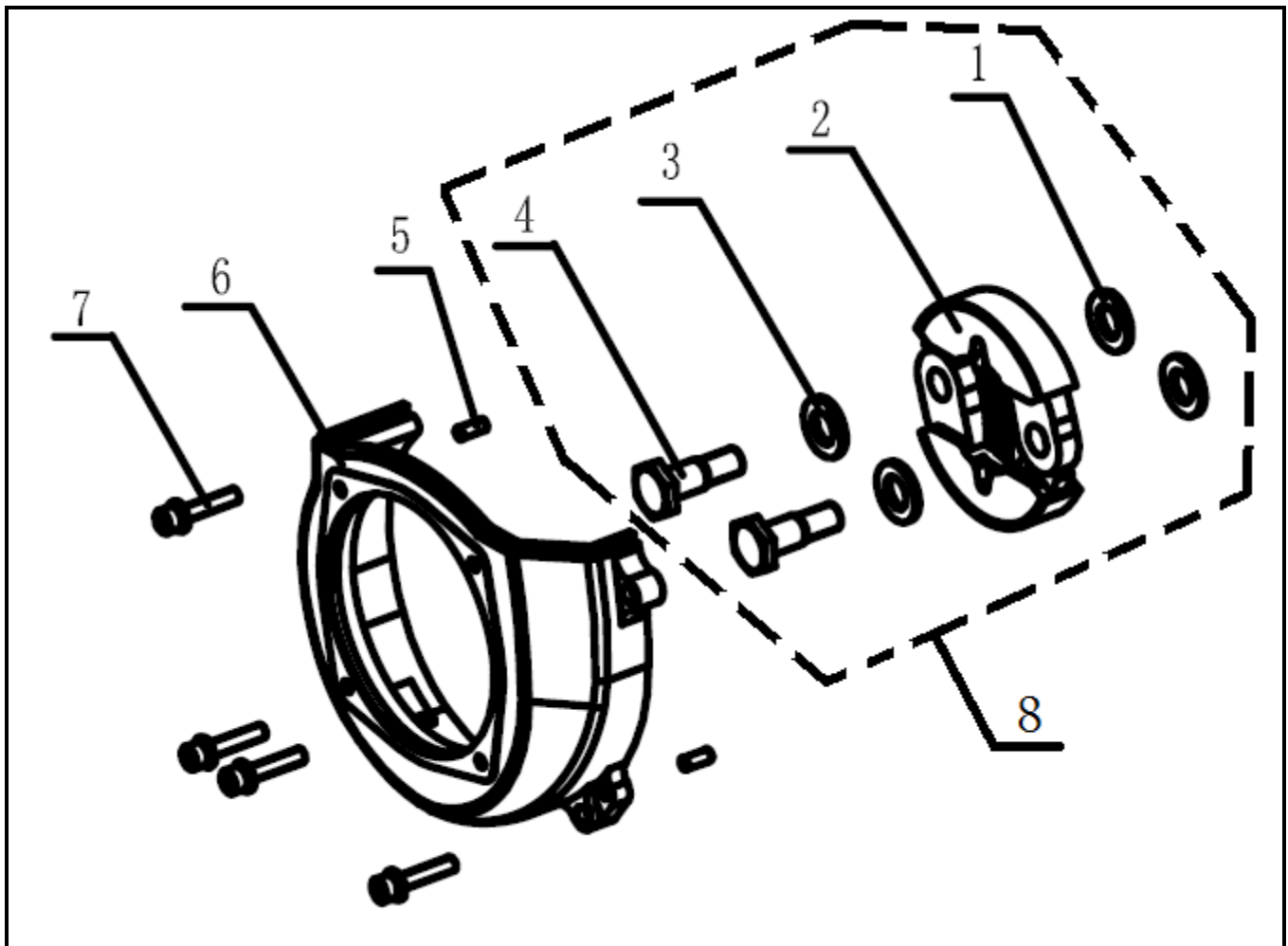

REF. NO.	DESCRIPTION	PART NO.	QTY
1	Flat Washer, M8	<i>Reference Only</i>	2
2	Clutch Shoes and Spring	<i>Reference Only</i>	1
3	Wave Spring Washer, M8	<i>Reference Only</i>	2
4	Bolt, M8 x 1.25 x 24, Hex Head Shoulder	<i>Reference Only</i>	2
5	Pin	<i>Reference Only</i>	2
6	Cover, Flywheel	A203679	1
7	Screw, M5 x 0.8 x 23, PHPD	<i>Reference Only</i>	4
8	Assembly, Clutch	A200782	1

Recoil Starter Assembly

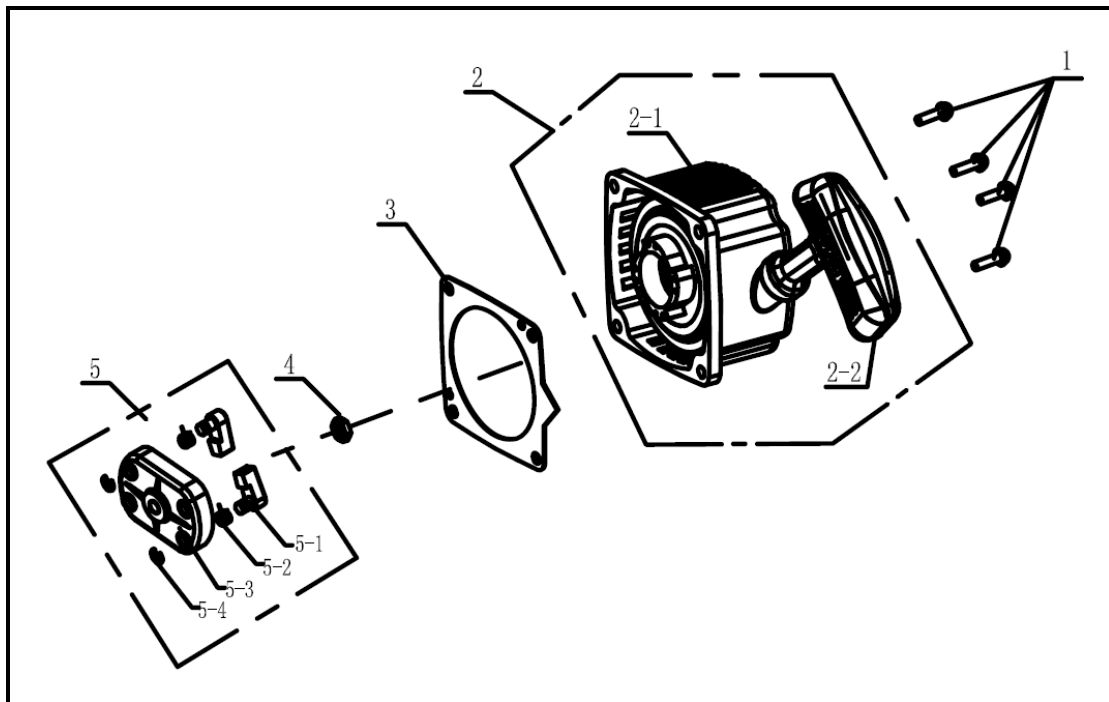

REF. NO.	DESCRIPTION	PART NO.	QTY
1	Screw, M5 x 0.8 x 20, PHPD	<i>Reference Only</i>	4
2	Recoil Starter	A203645	1
2-1	Recoil	<i>Reference Only</i>	1
2-2	Handle, Recoil Starter	<i>Reference Only</i>	1
3	Gasket, Recoil Starter	A200865	1
4	Nut, M8 x 1.25	<i>Reference Only</i>	1
5	Assembly, Starter Pawl	A200697	1
5-1	Ratchet, Starting	<i>Reference Only</i>	2
5-2	Spring, Returning	<i>Reference Only</i>	2
5-3	Base, Starting Ratchet	<i>Reference Only</i>	1
5-4	Clip	<i>Reference Only</i>	2

Cylinder Assembly

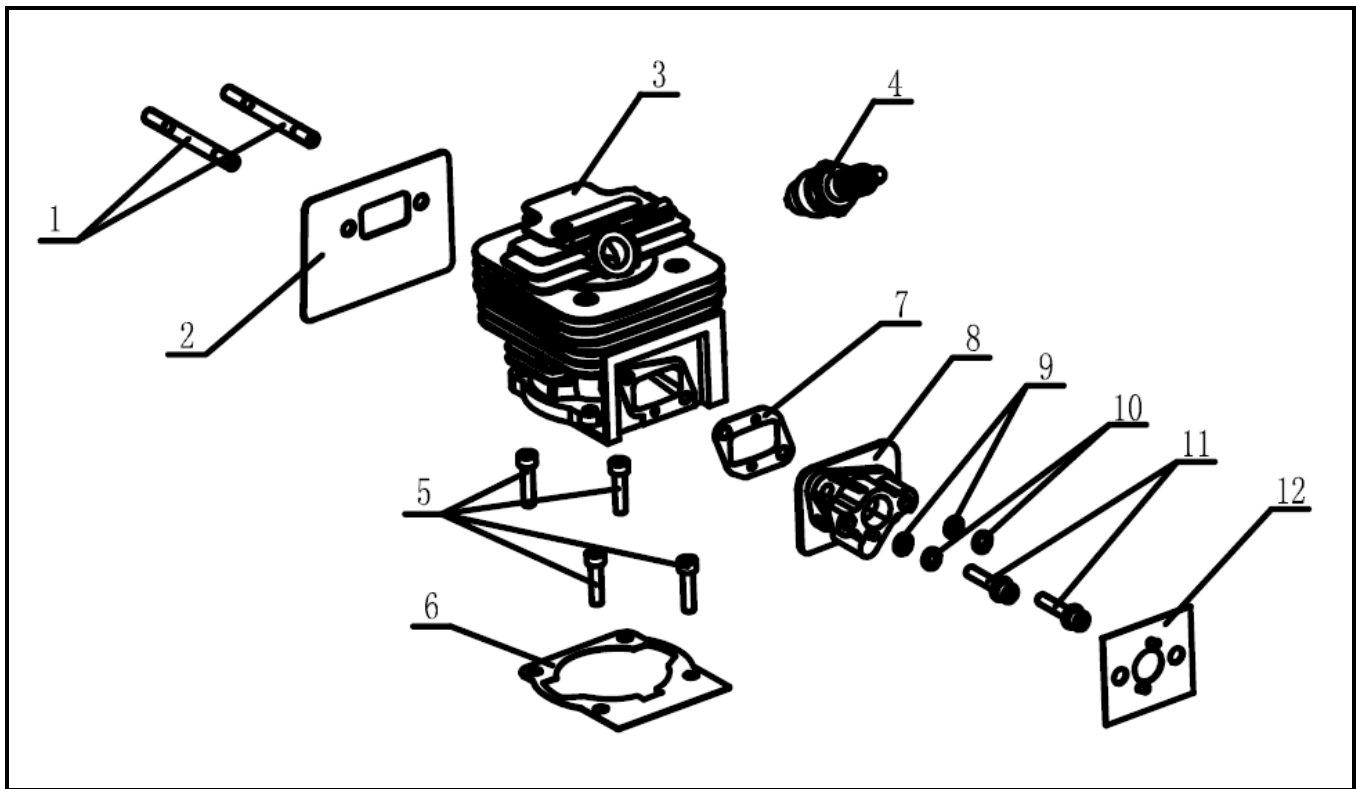

REF. NO.	DESCRIPTION	PART NO.	QTY
1	Stud, M6 x 1.0 x 63	<i>Reference Only</i>	2
2	Gasket, Muffler	A201107	1
3	Cylinder	<i>Reference Only</i>	1
4	Spark Plug	A200730	1
5	Screw, M5 x 0.8 x 20, SHCS, Grade 8.8	<i>Reference Only</i>	4
6	Gasket, Cylinder	<i>Reference Only</i>	1
7	Gasket, Isolator	A200838	1
8	Assembly, Carburetor Isolator	A200839	1
9	Flat Washer, M5	<i>Reference Only</i>	2
10	Lock Washer, M5	<i>Reference Only</i>	2
11	Screw, M5 x 0.8 x 25, SHCS, Grade 8.8	<i>Reference Only</i>	2
12	Gasket, Carburetor	A200841	1

Ignition Assembly

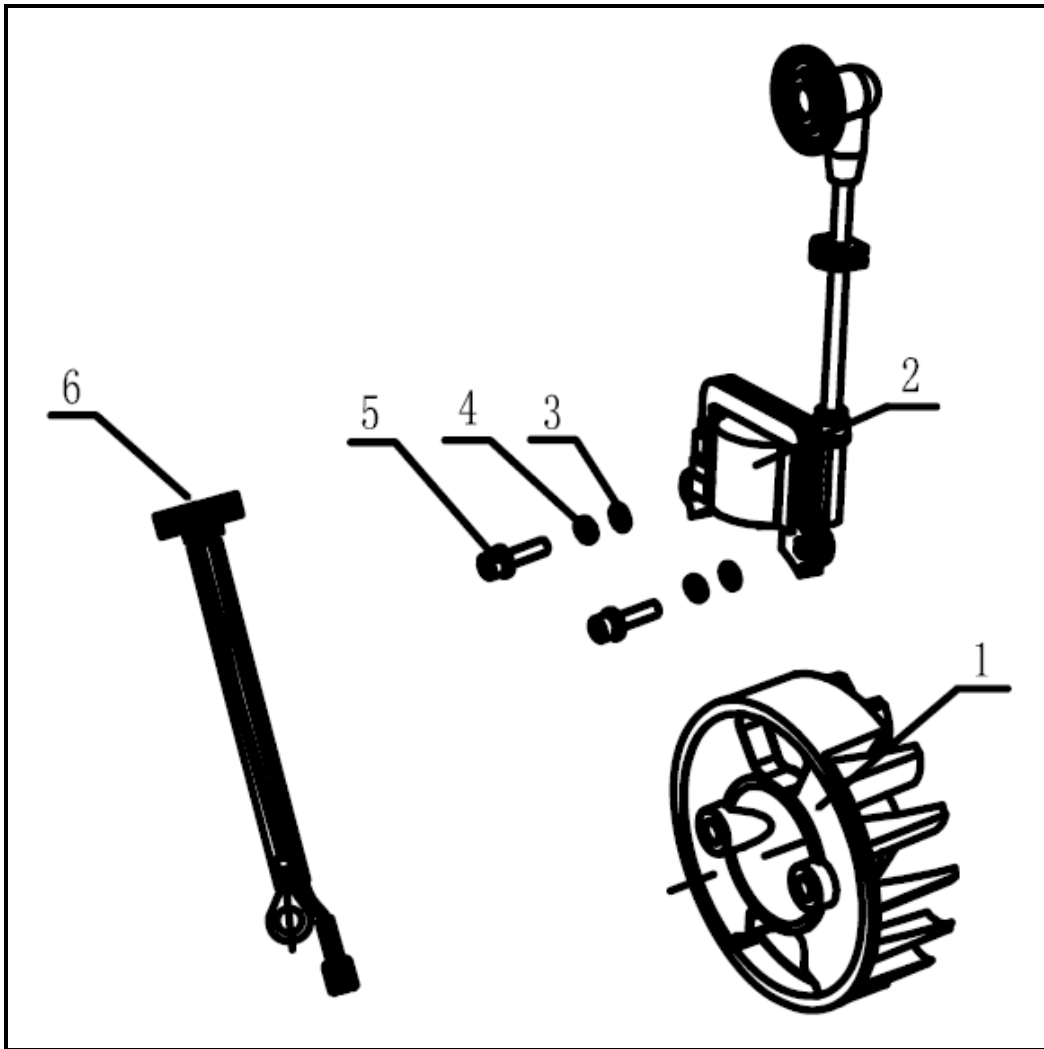

REF. NO.	DESCRIPTION	PART NO.	QTY
1	Flywheel	A202704	1
2	Ignition Module	A202703	1
3	Flat Washer, M5	<i>Reference Only</i>	2
4	Lock Washer, M5	<i>Reference Only</i>	2
5	Screw, M5 x 0.8 x 20, SHCS, Grade 8.8	<i>Reference Only</i>	2
6	Wire Harness	A203678	1

Air Cooling Assembly

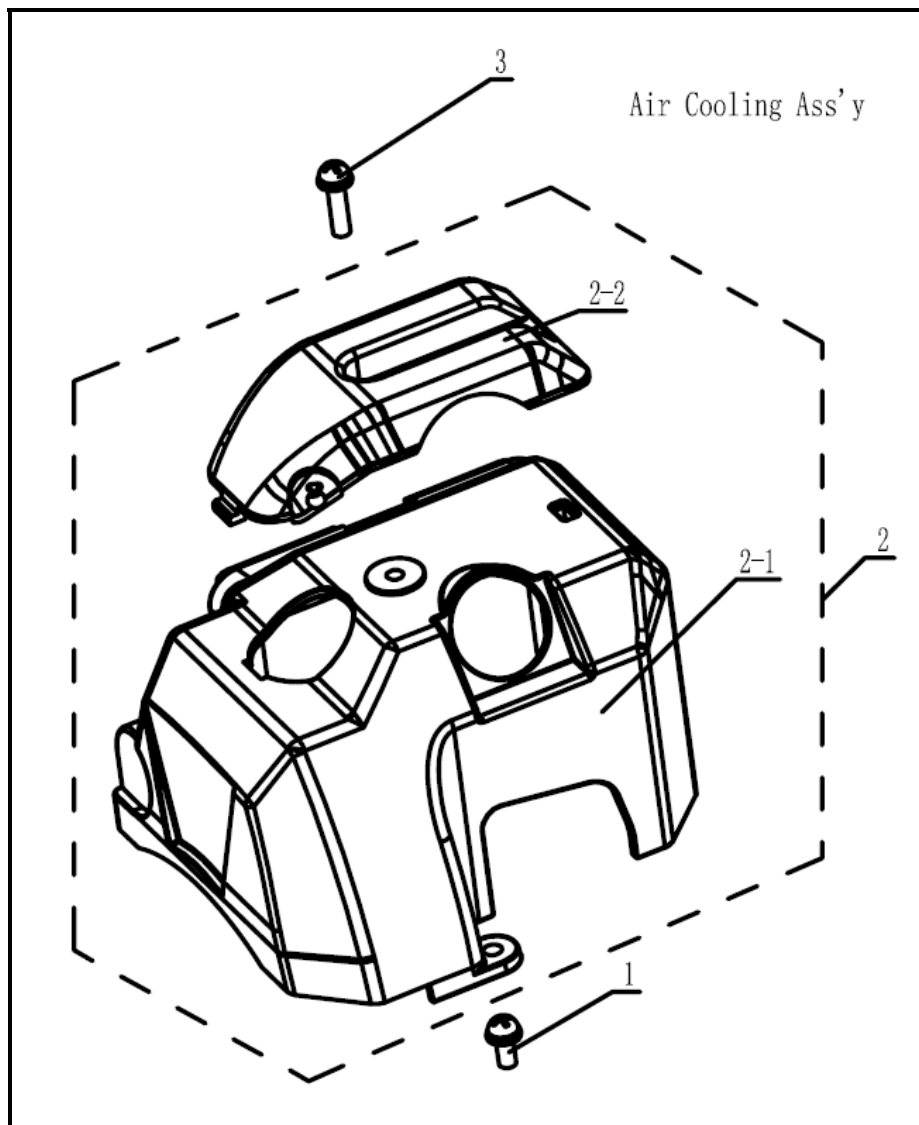

REF. NO.	DESCRIPTION	PART NO.	QTY
1	Screw, M5 x 0.8 x 16, PHPD	<i>Reference Only</i>	1
2	Assembly, Air Cover	A203676	1
2-1	Cover, Cylinder	<i>Reference Only</i>	1
2-2	Cover, Air Cooling	<i>Reference Only</i>	1
3	Screw, M5 x 0.8 x 23, PHPD	<i>Reference Only</i>	1

Engine Air Intake Screen Assembly

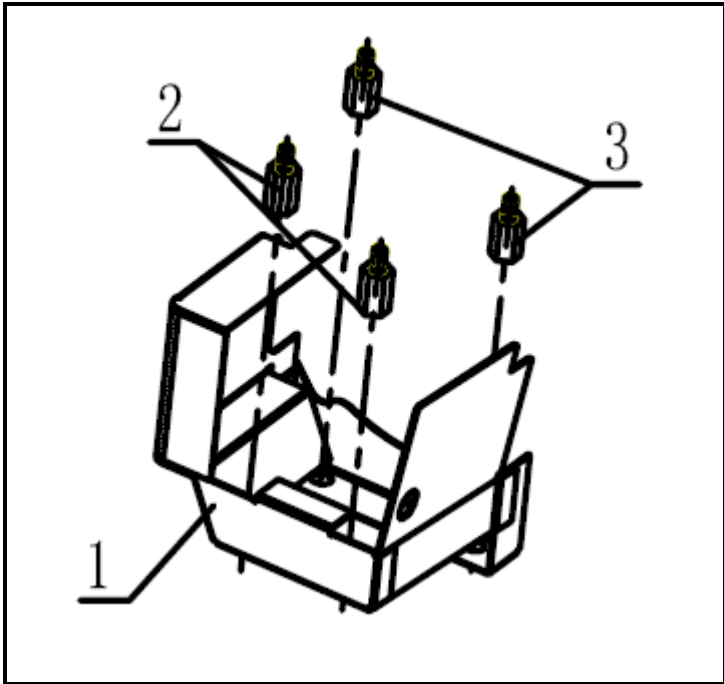

REF. NO.	DESCRIPTION	PART NO.	QTY
1	Screen, Engine Air Intake	<i>Reference Only</i>	1
2	Bushing 1	<i>Reference Only</i>	2
3	Bushing 2	<i>Reference Only</i>	2
4	Assembly, Engine Air Intake Screen (Includes items #1-3)	A203677	1

Decal Kit

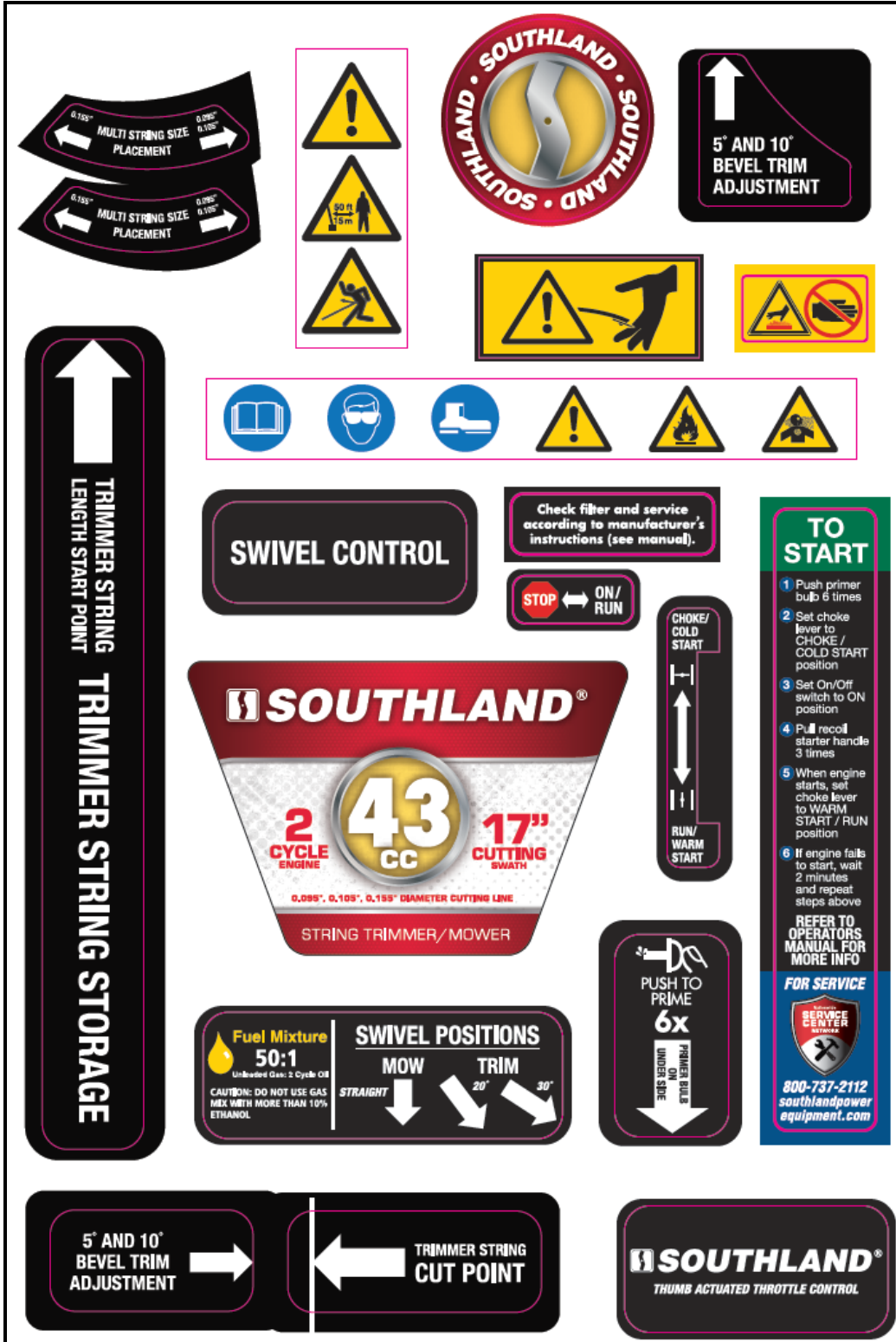

REF. NO.	DESCRIPTION	PART NO.	QTY
1	Decal Kit	A203639	1