

POWERMATIC®

WMH | TOOL GROUP

Operating Instructions and Parts Manual 12" Jointer

Model 1285



WMH TOOL GROUP

2420 Vantage Drive
Elgin, Illinois 60123
Ph.: 800-274-6848
www.wmhtoolgroup.com

Part No. M-0460216
Revision C1 12/05
Copyright © WMH Tool Group

This manual has been prepared for the owner and operators of a Powermatic Model 1285 Jointer. Its purpose, aside from machine operation, is to promote safety using accepted operating and maintenance procedures. To obtain maximum life and efficiency from your jointer and to aid in using it safely, please read this manual thoroughly and follow the instructions carefully.

Warranty and Service

WMH Tool Group warrants every product it sells. If one of our tools needs service or repair, one of our Authorized Service Center located throughout the United States can provide quick service or information.

In most cases, a WMH Tool Group Service Center can assist in authorizing repair work, obtaining parts, or perform routine or major maintenance repair on your Powermatic product.

For the name of an Authorized Service Center in your area, please call 1-800-274-6848, or visit our web site at www.wmhtoolgroup.com

More Information

Remember, WMH Tool Group is consistently adding new products to the line. For complete, up-to-date product information, check with your local WMH Tool Group distributor, or visit our web site at www.wmhtoolgroup.com

WMH Tool Group Warranty

WMH Tool Group makes every effort to assure that its products meet high quality and durability standards and warrants to the original retail consumer/purchaser of our products that each product be free from defects in materials and workmanship as follows: 1 YEAR LIMITED WARRANTY ON ALL PRODUCTS UNLESS SPECIFIED OTHERWISE. This Warranty does not apply to defects due directly or indirectly to misuse, abuse, negligence or accidents, normal wear-and-tear, repair or alterations outside our facilities, or to a lack of maintenance.

WMH TOOL GROUP LIMITS ALL IMPLIED WARRANTIES TO THE PERIOD SPECIFIED ABOVE, BEGINNING FROM THE DATE THE PRODUCT WAS PURCHASED AT RETAIL. EXCEPT AS STATED HEREIN, ANY IMPLIED WARRANTIES OR MERCHANTABILITY AND FITNESS ARE EXCLUDED. SOME STATES DO NOT ALLOW LIMITATIONS ON HOW LONG THE IMPLIED WARRANTY LASTS, SO THE ABOVE LIMITATION MAY NOT APPLY TO YOU. IN NO EVENT SHALL WMH TOOL GROUP BE LIABLE FOR DEATH, INJURIES TO PERSONS OR PROPERTY, OR FOR INCIDENTAL, CONTINGENT, SPECIAL, OR CONSEQUENTIAL DAMAGES ARISING FROM THE USE OF OUR PRODUCTS. SOME STATES DO NOT ALLOW THE EXCLUSION OR LIMITATION OF INCIDENTAL OR CONSEQUENTIAL DAMAGES, SO THE ABOVE LIMITATION OR EXCLUSION MAY NOT APPLY TO YOU.

To take advantage of this warranty, the product or part must be returned for examination, postage prepaid, to an Authorized Service Center designated by our office. Proof of purchase date and an explanation of the complaint must accompany the merchandise. If our inspection discloses a defect, we will either repair or replace the product at our discretion, or refund the purchase price if we cannot readily and quickly provide a repair or replacement. We will return the repaired product or replacement at WMH Tool Group's expense, but if it is determined there is no defect, or that the defect resulted from causes not within the scope of WMH Tool Group's warranty, then the user must bear the cost of storing and returning the product. This warranty gives you specific legal rights; you may also have other rights, which vary from state to state.

WMH Tool Group sells through distributors only. Members of the WMH Tool Group reserve the right to effect at any time, without prior notice, alterations to parts, fittings and accessory equipment, which they may deem necessary for any reason whatsoever.

Table of Contents

Warranty and Service.....	2
Warning.....	4
Introduction.....	7
Specifications.....	7
Unpacking.....	8
Contents of the Shipping Container.....	8
Assembly.....	9
Fence Installation.....	9
Switch Arm.....	10
Dust Hood.....	10
Grounding Instructions.....	10
Voltage Conversion.....	11
Extension cords.....	11
Adjustments.....	12
Drive Belt Tension.....	12
Setting Outfeed Table Height.....	12
Setting Infeed Table Height (Depth of Cut).....	14
Replacing and Setting Knives (Straight Cutterhead).....	14
Replacing Knife Inserts (Helical Cutterhead).....	16
Fence Adjustments.....	17
Cutter Guard Tension.....	18
Operating Controls.....	18
Operation.....	18
Hand Placement.....	19
Edge Jointing.....	19
Surfacing.....	19
Rabbeting.....	19
Jointing Warped Surfaces.....	20
Jointing Short or Thin Work.....	20
Direction of Grain.....	20
Beveling.....	20
Maintenance.....	21
Lubrication.....	21
Cutterhead Repairs.....	21
Knife Inserts (Helical Cutterhead).....	22
Whetting Knives (Straight Cutterhead).....	23
Optional Accessories.....	27
Replacement Parts.....	27
Parts List: Stand Assembly.....	28
Stand Assembly.....	29
Parts List: Table Assembly.....	30
Table Assembly.....	31
Parts List: Motor Pulley Assembly.....	32
Motor Pulley Assembly.....	33
Parts List: Cutterhead Guard Assembly.....	34
Cutterhead Guard Assembly.....	35
Parts List: Straight Cutterhead Assembly.....	36
Straight Cutterhead Assembly.....	37
Parts List: Helical Cutterhead Assembly.....	38
Helical Cutterhead Assembly.....	39
Parts List: Fence Assembly.....	40
Fence Assembly.....	41
Electrical Connections – 1 Phase.....	42
Electrical Connections – 3 Phase.....	43

Warnings

1. Read and understand the entire owners manual before attempting assembly or operation.
2. Read and understand the warnings posted on the machine and in this manual. Failure to comply with all of these warnings may cause serious injury.
3. Replace the warning labels if they become obscured or removed.
4. This jointer is designed and intended for use by properly trained and experienced personnel only. If you are not familiar with the proper and safe operation of a jointer, do not use until proper training and knowledge have been obtained.
5. Do not use this jointer for other than its intended use. If used for other purposes, WMH Tool Group disclaims any real or implied warranty and holds itself harmless from any injury that may result from that use.
6. Always wear approved safety glasses/face shields while using this jointer. Everyday eyeglasses only have impact resistant lenses; they are not safety glasses.
7. Before operating this jointer, remove tie, rings, watches and other jewelry, and roll sleeves up past the elbows. Remove all loose clothing and confine long hair. Non-slip footwear or anti-skid floor strips are recommended. Do **not** wear gloves.
8. Wear ear protectors (plugs or muffs) during extended periods of operation.
9. Some dust created by power sanding, sawing, grinding, drilling and other construction activities contain chemicals known to cause cancer, birth defects or other reproductive harm. Some examples of these chemicals are:
 - Lead from lead based paint.
 - Crystalline silica from bricks, cement and other masonry products.
 - Arsenic and chromium from chemically treated lumber.Your risk of exposure varies, depending on how often you do this type of work. To reduce your exposure to these chemicals, work in a well-ventilated area and work with approved safety equipment, such as face or dust masks that are specifically designed to filter out microscopic particles.
10. Do not operate this machine while tired or under the influence of drugs, alcohol or any medication.
11. Make certain the switch is in the **OFF** position before connecting the machine to the power supply.
12. Make certain the machine is properly grounded.
13. Make all machine adjustments or maintenance with the machine unplugged from the power source.
14. Remove adjusting keys and wrenches. Form a habit of checking to see that keys and adjusting wrenches are removed from the machine before turning it on.
15. Keep safety guards in place at all times when the machine is in use, the only exception being special operations such as rabbet cuts which require removal of the cutter guard. If guards are removed for maintenance purposes or special operations, use extreme caution and replace the guards immediately when finished.
16. Check damaged parts. Before further use of the machine, a guard or other part that is damaged should be carefully checked to determine that it will operate properly and perform its intended function. Check for alignment of moving parts, binding of moving parts, breakage of parts, mounting and any other conditions that may affect its operation. A guard or other part that is damaged should be properly repaired or replaced.
17. Provide for adequate space surrounding work area and non-glare, overhead lighting.
18. Keep the floor around the machine clean and free of scrap material, oil and grease.

Warnings

19. Keep visitors a safe distance from the work area. **Keep children away.**
20. Make your workshop child proof with padlocks, master switches or by removing starter keys.
21. Give your work undivided attention. Looking around, carrying on a conversation and “horse-play” are careless acts that can result in serious injury.
22. Maintain a balanced stance at all times so that you do not fall or lean against the knives or other moving parts. Do not overreach or use excessive force to perform any machine operation.
23. Use the right tool at the correct speed and feed rate. Do not force a tool or attachment to do a job for which it was not designed. The right tool will do the job better and safer.
24. Use recommended accessories; improper accessories may be hazardous.
25. Maintain tools with care. Keep knives sharp and clean for the best and safest performance. Follow instructions for lubricating and changing accessories.
26. Turn off the machine before cleaning. Use a brush or compressed air to remove chips or debris — do not use your hands.
27. Do not stand on the machine. Serious injury could occur if the machine tips over.
28. Never leave the machine running unattended. Turn the power off and do not leave the machine until the cutterhead comes to a complete stop.
29. Remove loose items and unnecessary work pieces from the area before starting the machine.
30. Never surface stock less than 12 inches long, or 3 inches wide, or 3 inches thick without a hold-down or push block.

31. When working on the jointer, follow the 3-inch radius rule. The hands must never be closer than 3 inches to the cutterhead. See Figure A.

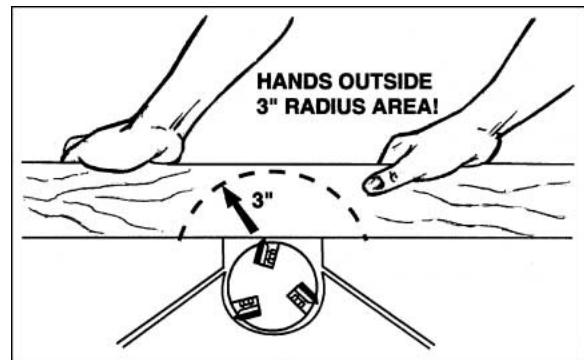

Figure A

32. Use extra care in the location of the jointer in the shop. Position the jointer so that potential kicked back stock will strike a wall and not endanger other persons in the area.

33. Never apply pressure to stock directly over the cutterhead. This may result in the stock tipping into the cutterhead along with the operator's fingers. Follow the 3-inch rule. Position hands away from extreme ends of stock, and push through with a smooth, even motion.

34. “Pull-out” and the danger of kicked back stock can occur when the work piece has knots, holes, or foreign materials such as nails. It can also occur when the stock is fed against the grain on the jointer. The grain should run in the same direction you are cutting.

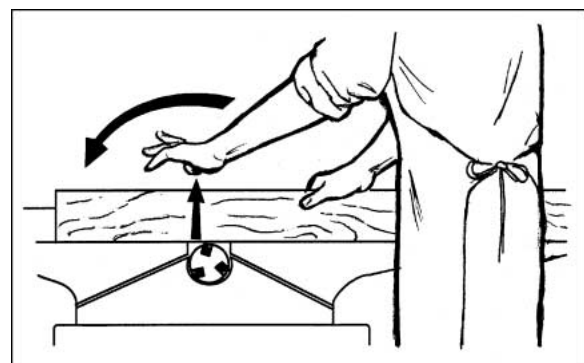

Figure B

35. It is good practice to move the hands in an alternate motion from back to front as the work continues through the cut. Never pass the hands directly over the cutter knife. As one hand approaches the knives, remove it from the stock in an arc motion and place it back on the stock in a position beyond the cutter knife. See Figure B. At all times hold the stock firmly.

36. Before attempting to joint or plane, each work piece must be carefully examined for stock condition and grain orientation. NOTE: At certain times it may be necessary to plane against the grain when working with a swirl grain wood or burls. With this type of work the operator must use a lesser depth of cut and a slow rate of feed.

Familiarize yourself with the following safety notices used in this manual:

▲CAUTION This means that if precautions are not heeded, it may result in minor injury and/or possible machine damage.

▲WARNING This means that if precautions are not heeded, it may result in serious injury or possibly even death.

- - SAVE THESE INSTRUCTIONS - -

Introduction

This manual is provided by Powermatic covering the safe operation and maintenance procedures for a Model 1285 Jointer. This manual contains instructions on installation, safety precautions, general operating procedures, maintenance instructions and parts breakdown. This machine has been designed and constructed to provide years of trouble free operation if used in accordance with instructions set forth in this manual. If there are any questions or comments, please contact either your local supplier or WMH Tool Group. WMH Tool Group can also be reached at our web site: www.wmhtoolgroup.com.

Specifications

Model Number.....	1285
Stock Number (3HP, 1Ph, 230V, with standard cutterhead).....	1791241
Stock Number (3HP, 3Ph, 230V/460V*, with standard cutterhead).....	1791249
Stock Number (3HP, 1Ph, 230V, with helical cutterhead).....	1791307
Stock Number (3HP, 3Ph, 230V/460V*, with helical cutterhead).....	1791308
Cutting Capacity (W x D) (in.).....	11-3/4 x 3/4
Cutterhead Speed (RPM).....	5,000
Rabbeting Capacity (in.).....	3/4
Table Surface (L x W) (in.).....	84 x 12
Outfeed Table Height from Floor (in.).....	31-5/8
Fence Size (L x W) (in.).....	47-1/4 x 5-1/4
Fence Tilt (degrees).....	90, 45 right, 45 left
Fence Positive Stops (deg.).....	45 and 90
Number of Knives – standard cutterhead.....	3
Number of Inserts – helical cutterhead.....	44, with 2 rabbeting
Size of knives – standard cutterhead (L x W x T) (in.).....	12 x 13/16 x 1/8
Dust Collection Minimum CFM Required.....	800
Approximate Net Weight (lbs.).....	762
Approximate Shipping Weight (lbs.).....	880

*pre-wired 230V

The above specifications were current at the time this manual was published, but because of our policy of continuous improvement, WMH Tool Group reserves the right to change specifications at any time and without prior notice, without incurring obligations.

Unpacking

Open shipping container and check for shipping damage. Report any damage immediately to your distributor and shipping agent. Compare the contents of your container with the following parts list to make sure all parts are intact. Missing parts, if any, should be reported to your distributor. Read the instruction manual thoroughly for assembly, maintenance and safety instructions.

NOTE: The wrenches and knife setting gauge will be found inside the jointer stand.

Contents of the Shipping Container

- 1 Jointer
- 1 Fence Assembly
- 1 Dust Hood
- 1 Knife Setting Gauge
- 1 Hex Wrench, 10mm
- 1 Combination Wrench, 10-12mm
- 2 Push Blocks
- 1 Owner's Manual
- 1 Warranty Card

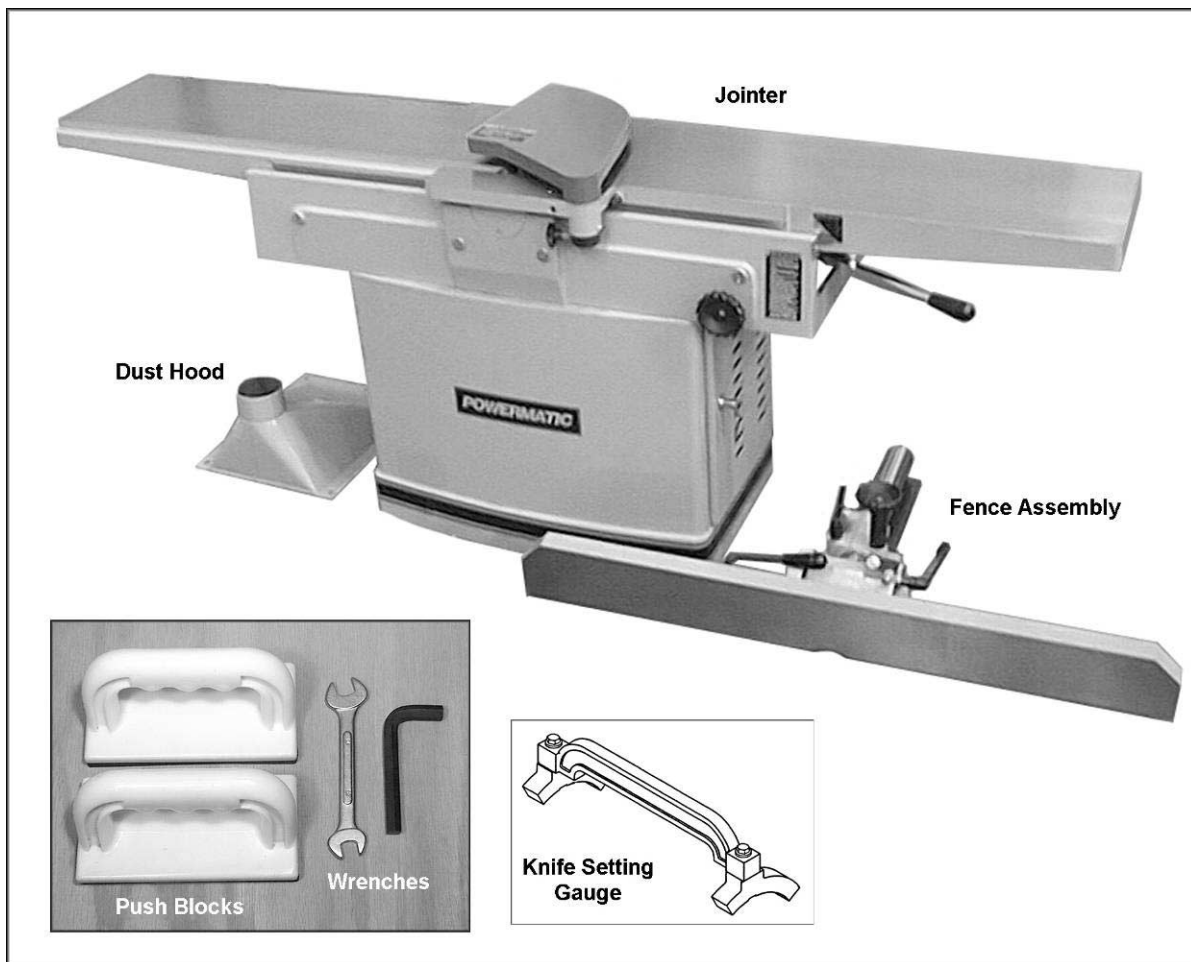

▲WARNING

Read and understand the entire contents of this manual before attempting set-up or operation! Failure to comply may cause serious injury.

Assembly

Tools need for assembly:

10mm hex wrench (provided)
10-12mm combination wrench (provided)
forklift or hoist with straps
cross-point screwdriver

1. Remove top and sides of crate from around the machine.
2. Remove the dust hood and the fence assembly from the skid. Reach into the stand and remove the screws securing the stand to the skid.
3. Raise the jointer off the skid with lifting straps. The straps should be suitable to lift 762 pounds of weight, and should be placed under the base casting as shown in Figure 1. Do not lift the jointer under the infeed and outfeed tables.
4. The jointer should be placed on a sturdy, level floor in a dry area, with sufficient lighting and ventilation. Leave enough room around the machine for loading and offloading stock and routine maintenance work. The machine can be further stabilized by bolting it to the floor using lag screws through the holes on the inside of the stand.
5. This machine is equipped with noise-reducing table lips. The work site should, however, be one which minimizes reverberant sound from walls, ceilings and other equipment.
6. Exposed metal areas of the jointer, including the table and fence surfaces, have been factory coated with a protectant. This should be removed with a soft cloth dampened with a solvent such as mineral spirits or kerosene. Do not use gasoline, acetone or lacquer thinner, and do not use an abrasive pad. Do not let solvent contact the plastic parts of the machine, as it may damage them.

Fence Installation

1. Use an assistant to help place the fence assembly on top the table, aligning the holes in the fence assembly with the holes in the table base, as shown in Figure 2.
2. Use the two socket head cap screws and two lock washers (Figure 2), and tighten securely with a 10mm hex wrench.

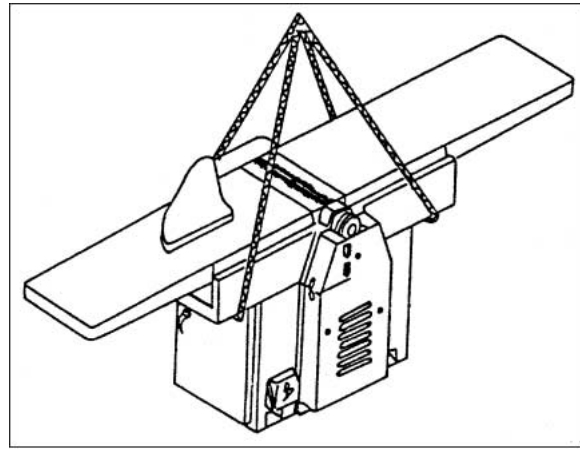

Figure 1

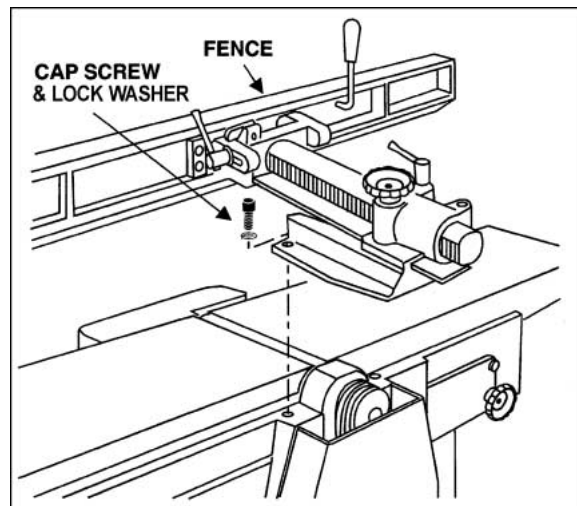

Figure 2

Switch Arm

The arm (Figure 3) on which the push button switch is located is shipped in the down position. The arm should be pivoted to upright position as shown. Tighten the two screws with a 10mm wrench.

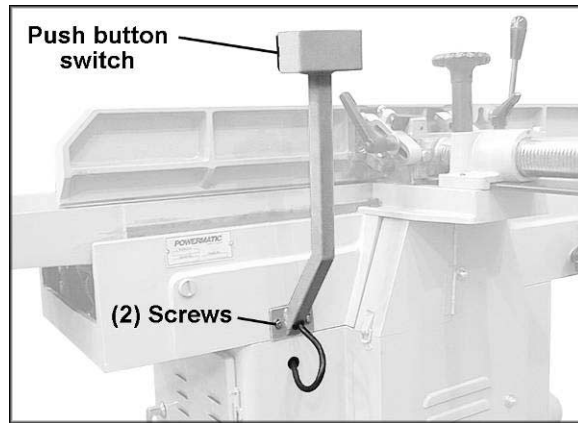

Figure 3

Dust Hood

Before attaching the dust hood, make sure the hole in the dust chute is concealed by the dust chute cover, as shown in Figure 4.

Mount the dust hood to the jointer stand using the seven 1/4 x 1/2 hex cap screws and seven 1/4 lock washers (Figure 5).

It is recommended that a dust collection system of at least 800 CFM be connected to the jointer's dust hood, via a 6-inch diameter hose.



Figure 4

Grounding Instructions

⚠WARNING Electrical connections must be made by a qualified electrician in compliance with all relevant codes. This machine must be properly grounded to help prevent electrical shock and possible fatal injury.

This machine must be grounded. Grounding provides a path of least resistance to help divert current away from the operator in case of electrical malfunction.

Make sure the voltage of your power supply matches the specifications on the motor plate of the machine.

Open the junction box (Figure 6) and connect the wires according to the diagram on the inside of the junction box cover. A similar diagram can be found at the back of this manual. The green wire (ground) must be properly grounded.

The Model 1285 may be fitted with an appropriate plug, or be "hard-wired" to an electrical panel. If hard-wired to a panel, make sure a disconnect is available for the operator.

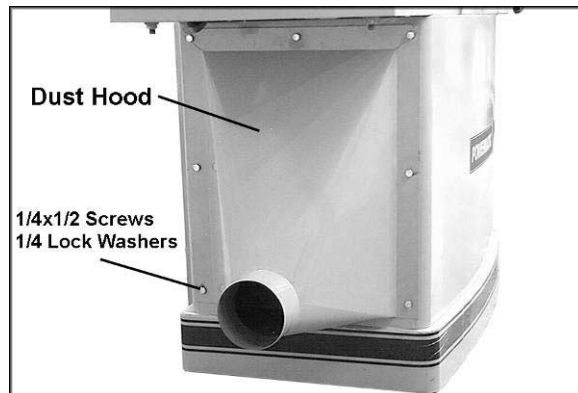

Figure 5

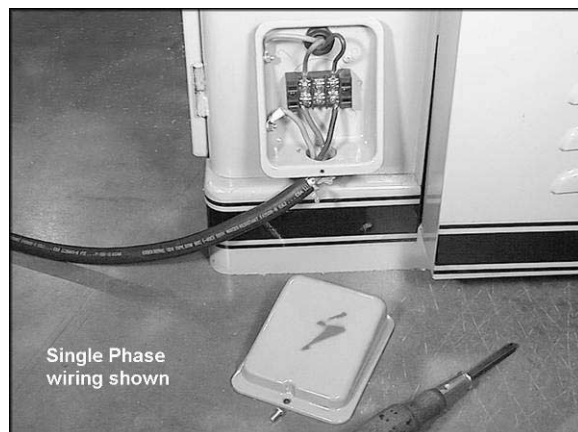

Figure 6

If the jointer is to be hard-wired, make sure the fuses have been removed or the breakers have been tripped in the circuit to which the saw will be connected. Place a warning placard on the fuse holder or circuit breaker to prevent it being turned on while the machine is being wired. Always follow proper Lock-Out/Tag-Out procedures when performing any wiring on this machine.

Voltage Conversion

The Model 1285 Jointer is wired for 1-phase, 230 volt only; or 3-phase, 230/460 volt. The 3-phase model is pre-wired at the factory for 230 volt. However, if you wish to convert your 3-phase jointer from 230 volt to 460 volt, proceed as follows:

1. Disconnect machine from power source.
2. Remove cover from junction box, and open the side door on the stand.
3. Change the wires in the junction box by following the diagram on the inside of the junction box cover, or the diagram found at the back of this manual.
4. Replace the 230 volt contactor (see Figure 7) with the 460 volt contactor (stock no. PJ1285-109). The 460 volt contactor is available through your authorized Powermatic distributor, or by calling 1-800-274-6848.
5. If you are using a plug on the jointer's power cord, install an appropriate 460 volt plug.
6. After wiring for the new voltage, turn on the machine and observe the rotation of the cutterhead; it should be dockwise when viewed from the front of machine. If it rotates counterclockwise, disconnect jointer from power source and switch any two of the three wires at the junction box.
7. Close junction box and reconnect power.

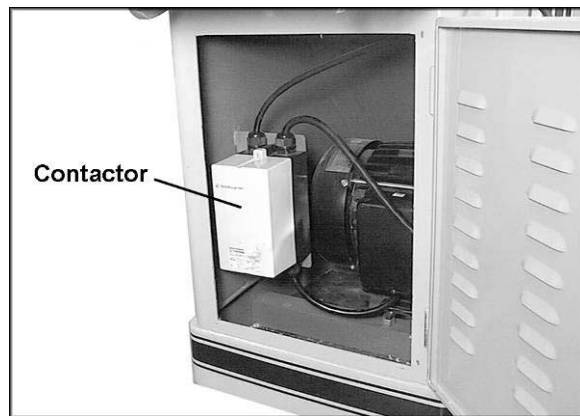

Figure 7

Extension cords

The use of an extension cord is not recommended, but if one is necessary make sure the cord rating is suitable for the amperage listed on the machine's motor plate. An undersized cord will cause a drop in line voltage resulting in loss of power and overheating.

Use the chart in Figure 8 as a general guide in choosing the correct size cord. If in doubt, use the next heavier gauge. The smaller the gauge number, the heavier the cord.

Cord Length 230V	Cord Gauge
50'	16 AWG
100'	16 AWG
200'	14 AWG
300'	12 AWG

Figure 8

Adjustments

⚠WARNING Disconnect jointer from power supply before making adjustments.

Drive Belt Tension

To check the tension of the drive belts:

1. Remove the three cap nuts and flat washers on the pulley cover with a 9/16 wrench, and remove the guard to expose the belts and pulleys. See Figure 9.

NOTE: The hex nuts and flat washers on the threaded rods (A, Figure 9) should be left in place; they keep the pulley cover from bending as it is being tightened back into place with the cap nuts.

2. There should be a small amount of deflection in the belt when pressing it midway between the pulleys with moderate finger pressure (Figure 10).
3. If the belts need tightening, loosen the lower hex nut (A, Figure 11) on the motor base with a 19mm wrench.
4. Turn the top hex nut (B, Figure 11) clockwise until proper tension is achieved.
5. Retighten lower hex nut (A, Figure 11).

NOTE: The belts should be inspected again after the first few times the machine is used, as the belts may stretch slightly during the “breaking-in” process.

Setting Outfeed Table Height

For accurate work in most jointing operations, the outfeed table must be exactly level with the knives/inserts at their highest point of revolution. The outfeed table on the Model 1285 has been pre-set at the factory to the proper height in relation to the cutterhead. However, the level of the outfeed table should be checked in case of slight misadjustment during shipping. Outfeed table height should also be inspected after re-setting or replacing knives/inserts.

1. The outfeed table has a stop screw (A, Figure 12) which, when contacting the edge of the table as shown, will ensure the outfeed table is at the proper height. Loosen the handwheel (C, Figure 12) and raise the outfeed table adjustment arm (D, Figure 12) until this stop screw (A, Figure 12) contacts the edge of the table as shown.

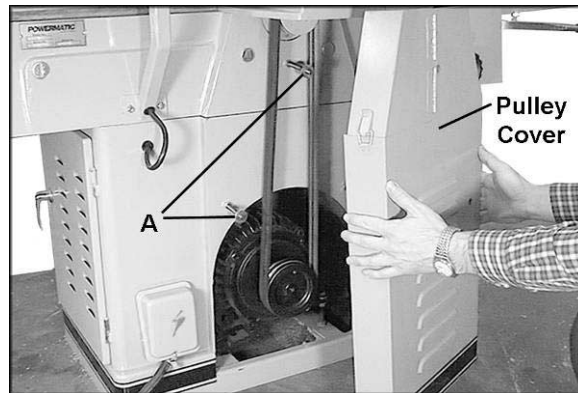

Figure 9

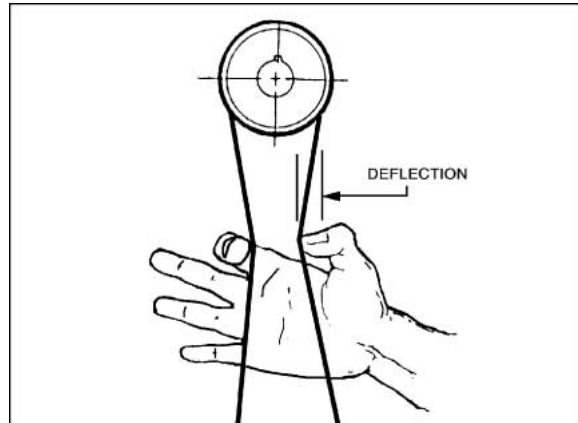

Figure 10

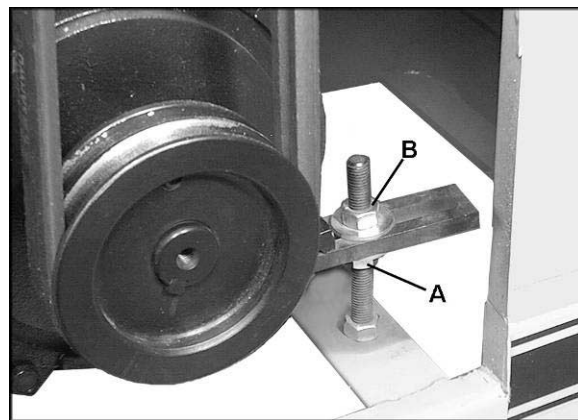

Figure 11

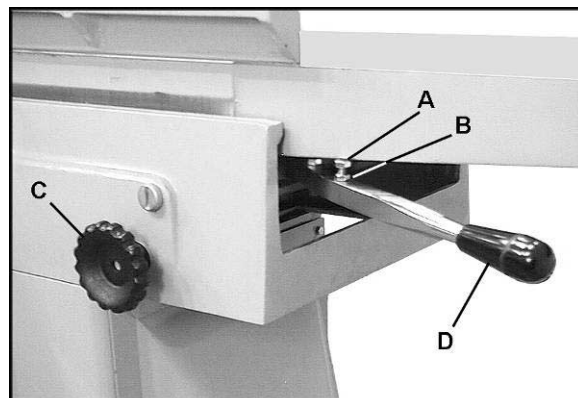

Figure 12

2. Place a straight edge on the outfeed table and extending over the cutterhead, as shown in Figure 13.
3. Rock the cutterhead slightly so that a knife tip contacts the straight edge. If the knife tip just contacts the straight edge without moving the straight edge, then the outfeed table is at the proper height. If the knife tip pushes up the straight edge, the outfeed table is too low. If the knife tip does not contact the straight edge, the outfeed table is too high.
4. To raise the height of the outfeed table, loosen the hex nut (B, Figure 12) and rotate the stop screw (A, Figure 12) clockwise. To lower the height of the outfeed table, rotate the stop screw (A, Figure 12) counter clockwise.
5. When the outfeed table is level with the knives, tighten the hex nut (B, Figure 12) and firmly tighten the handwheel (C, Figure 12).

After the outfeed table has been set, it should not be changed except for special operations.

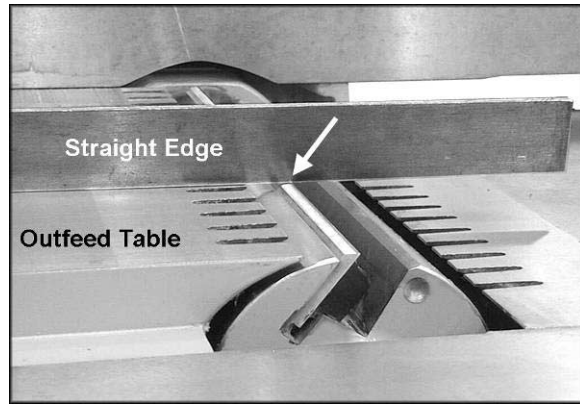

Figure 13

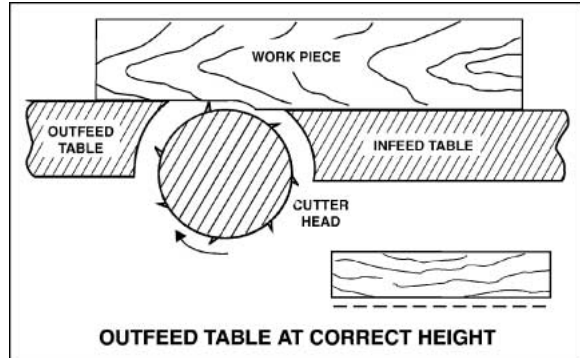

Figure 14

As a final check of the outfeed table adjustment, turn on the jointer and run a scrap piece of wood slowly over the knives for 6 to 8 inches; the wood should rest firmly on both tables, as shown in Figure 14, with no open space under the finished cut.

If the outfeed table is too high, the finished surface of the workpiece will be curved (Figure 15).

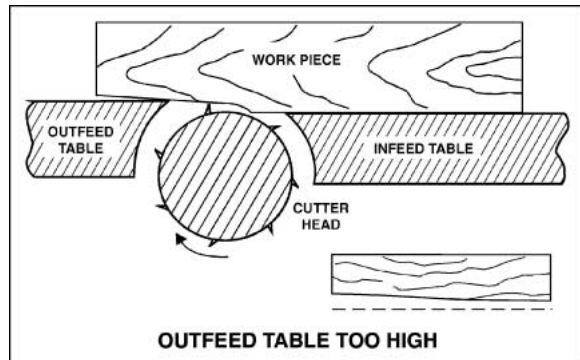

Figure 15

If the outfeed table is too low, the workpiece will be gouged at the end of the cut (Figure 16).

Make further changes to the stop screw if necessary to ensure the outfeed table is level with the knives/inserts.

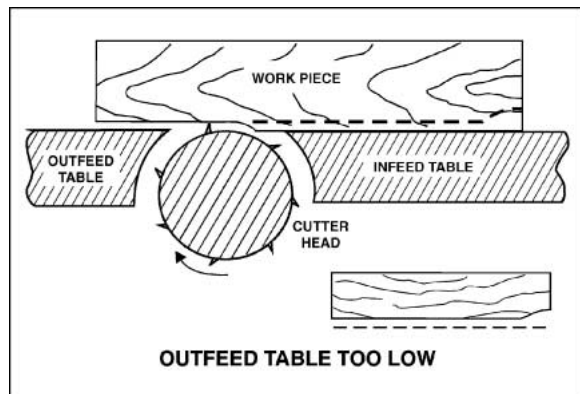

Figure 16

Setting Infeed Table Height (Depth of Cut)

1. To set the cutting depth, loosen handwheel (A, Figure 17) by turning counterclockwise.
2. Move table adjustment arm (B, Figure 17) up or down to raise or lower infeed table. The pointer (C, Figure 17) shows the depth of cut on the adjoining scale.
3. Tighten handwheel securely (A, Figure 17).

The stop screw (D, Figure 17) on the infeed table should be set so that when it contacts the table, the infeed table will be exactly level with the knives (with the scale pointer at zero). The setting of this stop screw has been made at the factory, but should be checked by the operator before using the jointer. It should also be checked occasionally as the machine receives use.

Use the same procedure as for the outfeed table, placing the straightedge across outfeed table, cutterhead and infeed table. Loosen the hex nut (E, Figure 17) and adjust the stop screw (D, Figure 17) as necessary. When finished, retighten hex nut (E, Figure 17).

If the infeed table is level with the knives but the scale pointer (C, Figure 17) appears to be off, loosen the scale pointer with a screwdriver and adjust it as needed until it reads zero. Retighten the screw.

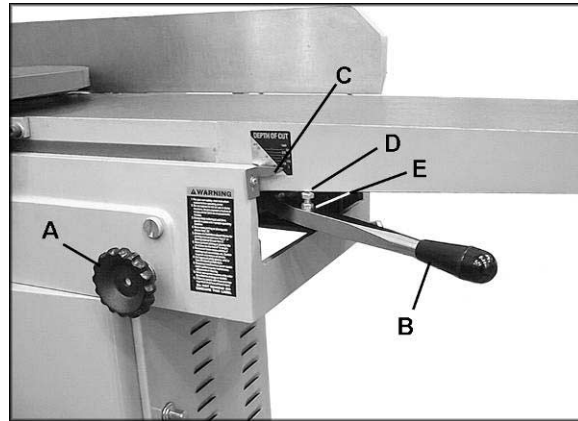

Figure 17

Replacing and Setting Knives (Straight Cutterhead)

CAUTION Jointer knives are very sharp. Use care and proceed slowly when working with or around the cutterhead.

After a period of use, dull knives should be reground or replaced. Remove the pulley cover at the rear of the machine – this will allow you to rotate the cutterhead by using the belts.

To remove a knife:

1. Disconnect machine from power source.
2. Back the fence away from the cutterhead as far as it will go. Lower infeed and outfeed tables.
3. Turn the six gib screws (Figure 18) into the gib with a 10mm wrench. As the pressure of the gib is released, the two springs in the cutterhead slot will cause the knife to rise.
4. Carefully remove the knife from the cutterhead.

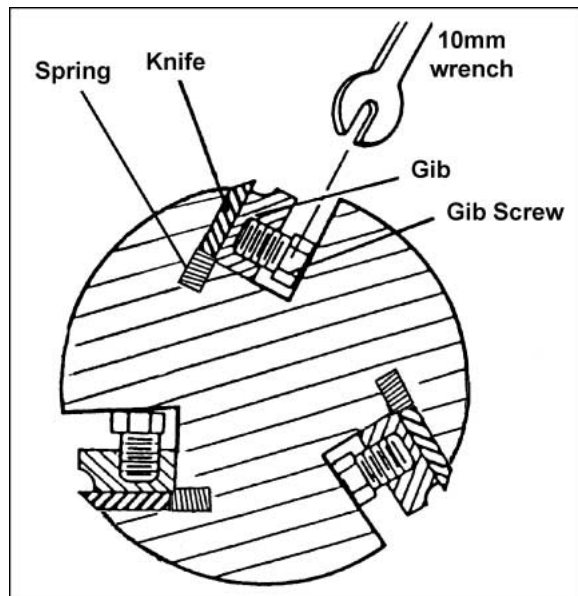

Figure 18

5. It is recommended when replacing knives that you clean the knife slots in the cutterhead. Remove the gib along with the cutterhead. Clean the cutterhead slot of any debris or dust that might prevent the knife from seating properly. Also clean the gib, gib screws, and springs. Closely inspect the gib screws – if the threads appear worn or stripped, or if the heads are becoming rounded, replace the screws.
6. Re-insert the springs and the gib.
7. Place the new or resharpened knife into the slot as shown in Figure 18, making sure the direction of the knife is correct.
8. Place the knife setting gauge (provided) upon the cutterhead and centered over a knife, as shown in Figure 19. Make sure the feet of the knife setting gauge rest solidly upon the cutterhead and that its handle is parallel to the cutterhead. The gauge is now holding the knife at proper depth.
9. While keeping the knife setting gauge in place, tighten the six gib screws just enough to hold the knife in position. Start with the center screws first, and work your way toward the end screws.
10. Repeat steps 3 through 9 for the other two knives in the cutterhead. Make the gib screws just tight enough to hold the knives in position.

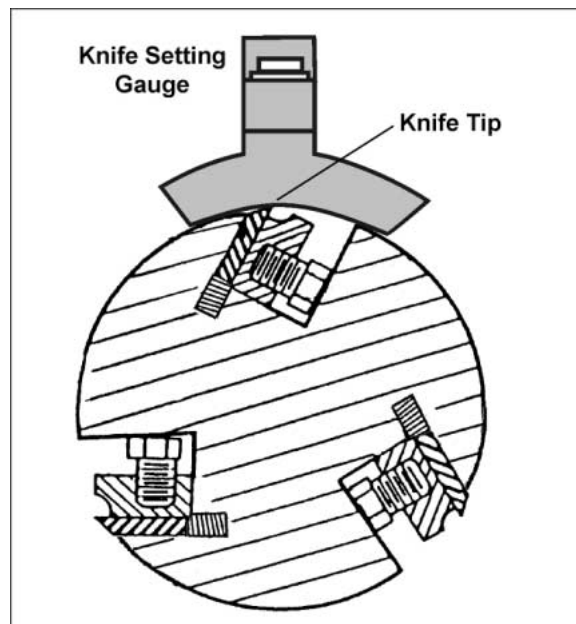

Figure 19

With all three jointer knives in the cutterhead, the knives should now be tightened incrementally to prevent any bucking or distortion of the cutterhead. Proceed as follows:

11. Rotate the cutterhead to each knife in turn, tightening the gib screws a little more (center screws first, then toward the end screws). Do this at least twice; on the final rotation, firmly tighten all gib screws.

▲WARNING After replacing and checking knives, check again carefully. Make certain the direction of knives is correct, and all eighteen gib screws are tightened securely. Loose gib screws can result in knives being thrown from the cutterhead, causing severe damage to the machine and possible serious or fatal injury to the operator or bystanders.

Replacing Knife Inserts (Helical Cutterhead)

CAUTION Jointer knife inserts are very sharp. Use care and proceed slowly when working with or around the cutterhead.

The helical cutterhead is a solid steel design that holds 44 two-sided knife inserts, and two rabbet knife inserts on the outboard end of the cutterhead. Replacing knife inserts is a simple process, and they will seat themselves properly without having to be set with a knife gauge.

After a period of use, dull knife inserts should be flipped over to present a new edge. If both edges are worn, knife inserts should be replaced.

1. Loosen the gib screw (A, Figure 20).
2. Remove the knife insert (B, Figure 20) with the gib (C, Figure 20) from its slot.
3. Make sure the slot (D, Figure 20) is free of dust and debris that would prevent the gib and insert from seating properly. Wipe out the slot and clean with solvent if needed.
4. Flip the knife insert 180 degrees and place it onto the two pins of the gib. Make sure the knife edge faces the proper direction (see Figure 21).
5. Re-install the gib into the slot.
6. Firmly tighten the gib screw (A, Figure 20).

NOTE: To ensure optimal cutting, all knife inserts in the cutterhead should be flipped at the same time. Of course, if an insert is nicked or damaged, it can be flipped or replaced individually as needed.

After installing a knife insert, be sure to tighten the gib screw before moving on to the next knife insert.

WARNING Make certain the direction of knife inserts is correct, and all gib screws are tightened securely. Loose gib screws can result in knife inserts being thrown from the cutterhead, causing severe damage to the machine and possible serious or fatal injury to the operator or bystanders.

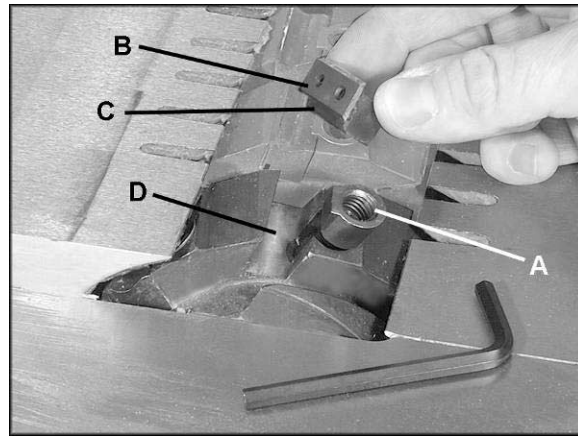

Figure 20

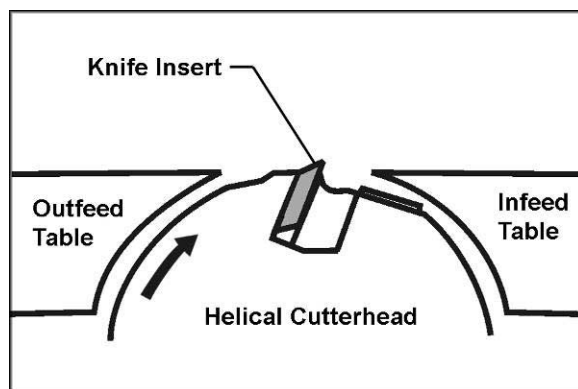

Figure 21

Fence Adjustments

The fence (A, Figure 22) tilts backward and forward to 45 degrees. It has a 90-degree stop (B, Figure 22) and a 45-degree stop (C, Figure 22).

To tilt fence forward:

1. Loosen the lock handle (D, Figure 22) and tilt the fence forward using the handle (E, Figure 22). NOTE: Lift up slightly on the fence while tilting it, to prevent scratching the table surface.
2. Retighten lock handle (D, Figure 22).

To tilt fence backward:

1. Loosen the lock handle (D, Figure 22) and pivot the stop block (F, Figure 22) out of the way.
2. Tilt the fence using the handle (E, Figure 22). NOTE: Lift up slightly on the fence while tilting it to prevent scratching the table surface.
3. Retighten lock handle (D, Figure 22).

To move fence forward or backward:

1. Loosen lock handle (G, Figure 22) and rotate handwheel (H, Figure 22); counterclockwise for forward fence movement, clockwise for backward fence movement.
2. When desired position is reached, securely tighten lock handle (G, Figure 22).

To check and adjust the 90-degree stop:

1. Loosen lock handle (D, Figure 23) and tilt fence until the stop screw (B, Figure 23) contacts the stop block (F, Figure 23).
2. Place a square or machinist's protractor (not provided) on the table and flush against the fence surface. See Figure 23.
3. If adjustment is necessary, loosen the hex nut on the stop screw (B, Figure 23) and turn the stop screw as needed until the fence is flush with your square.
4. Retighten the hex nut.

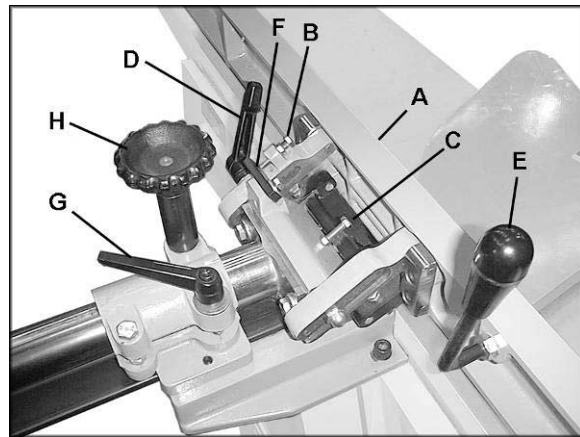

Figure 22

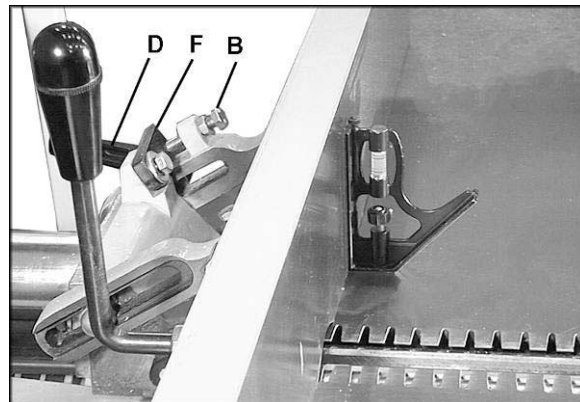

Figure 23

To check and adjust the 45-degree stop:

1. Loosen lock handle (D, Figure 22) and tilt fence until it contacts the 45-degree stop (C, Figure 22).
2. Place a machinist's protractor or similar device set at 45 degrees on the table and against the fence.
3. If adjustment is necessary, loosen the hex nut on the stop screw (C, Figure 22) and turn the stop screw until the fence is flush with the protractor.
4. Retighten the hex nut.

Cutter Guard Tension

The tension of the guard (Figure 24) must always be sufficient during jointer operations to cause the guard to conceal the unused part of the cutterhead, and to swing back to contact the fence after the workpiece has cleared the cutterhead. To adjust the guard tension:

1. Loosen the knob shown in Figure 24 and push the knob to the right to increase guard tension; or to the left to decrease guard tension.
2. Tighten the knob in that position.

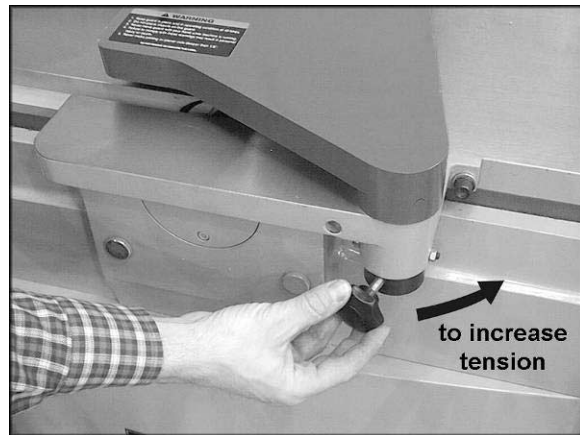

Figure 24

Operating Controls

The push button on/off switch is conveniently positioned above the table (Figure 25). Do not remove the clear plastic cover, as this keeps wood dust out of the switch.

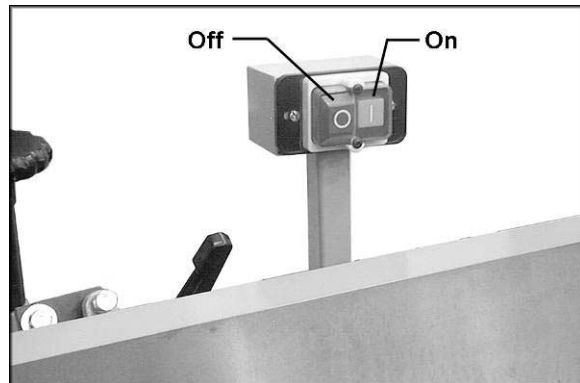

Figure 25

Operation

NOTE: If you are inexperienced at jointing, use scrap pieces of lumber to check settings and get the feel of operations before attempting regular work.

⚠WARNING Always use the guard whenever possible and keep hands away from cutterhead. Failure to comply may cause serious injury.

Ideally, the fence should be moved forward (toward the front of the machine) to expose only the amount of cutterhead needed for the workpiece.

TIP: If workpieces of the same size are constantly being run on the jointer, the operator may wish to occasionally adjust the fence forward or backward to prevent wear on only one area of the knives.

Hand Placement

At the start of the cut, the left hand holds the workpiece firmly against the infeed table and fence, while the right hand pushes the workpiece toward the knives. After the cut is under way, the jointed surface of the workpiece rests firmly on the outfeed table. The left hand should press down on this part, at the same time maintaining flat contact of the workpiece with the fence. The right hand pushes the workpiece forward and before the right hand reaches the cutterhead, the right hand should be moved to the workpiece on the outfeed table. The workpiece is then pushed on through to complete the cut. Follow the 3-inch rule (see page 5). Never pass hands directly over the cutterhead.

Edge Jointing

This is the most common operation for the jointer. Set the fence to the 90-degree stop and thus square with the table. Depth of cut should be the minimum required to obtain a straight edge. Do not make cuts deeper than 1/8" in a single pass. Hold the best face of the workpiece firmly against the fence throughout the feed. See Figure 26.

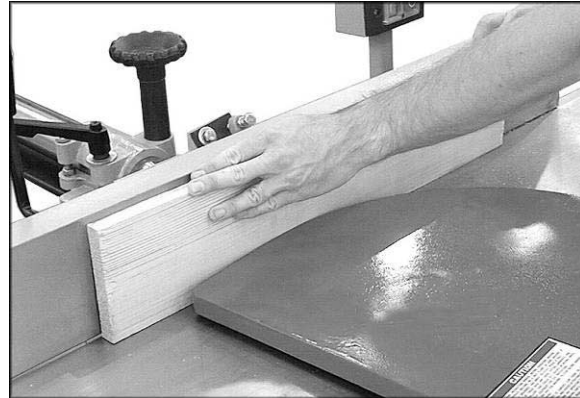

Figure 26

Surfacing

Jointing the face of stock, or surfacing is shown in Figure 27. Adjust the infeed table for depth of cut. Cuts of approximately 1/16" at a time are recommended, as this allows better control over the material being surfaced. More passes can then be made to reach the desired depth.



Figure 27

⚠WARNING Always use a hold-down or push block when surfacing short stock or stock less than 3 inches thick. Figure 26 shows push blocks being used for surfacing.

Rabbeting

A rabbet is a groove cut along the edge of a workpiece. See Figure 28. The width and thickness of the workpiece used will be dependent upon the desired width and length of the rabbet. However, **never** rabbet a workpiece less than 12 inches long.

⚠WARNING A rabbet cut requires removal of the cutterhead guard. Use extreme caution and keep hands clear of cutterhead. Always replace guard immediately after rabbeting operation is completed.

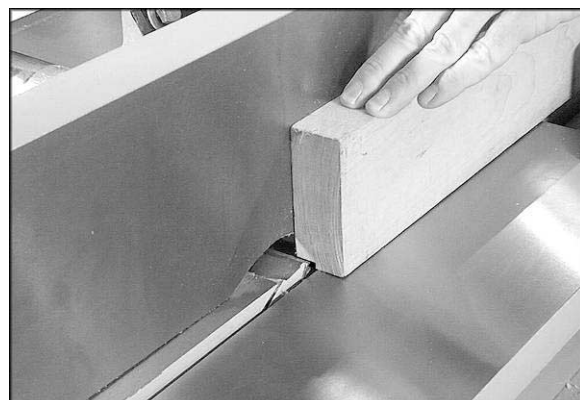

Figure 28

Use push blocks to rabbet cut whenever possible. The rabbeting capacity is 3/4".

1. Disconnect machine from power source.
2. Set fence for desired width of rabbet.
3. Check width of the rabbet by measuring the distance from the end of a knife in the cutterhead to the fence.
4. Reconnect power. Lower the infeed table 1/32" at a time and make successive cuts until the desired depth of rabbet has been obtained. See Figure 28. NOTE: It is easier and safer to take a series of shallow cuts.

Jointing Warped Surfaces

If the wood to be jointed is dished or warped, take light cuts until the surface is flat. Avoid forcing such material down against the table; excessive pressure will spring it while passing the knives, and it will spring back and remain curved after the cut is completed.

Jointing Short or Thin Work

When jointing short or thin pieces, use a push block to eliminate all danger to the hands. Two push blocks are shipped with your jointer, and additional ones (stock no. 6285917) can be purchased from your distributor or by calling 1-800-274-6848. You can also make your own easily from scrap material. Three types of commonly used push blocks are represented in Figure 29.

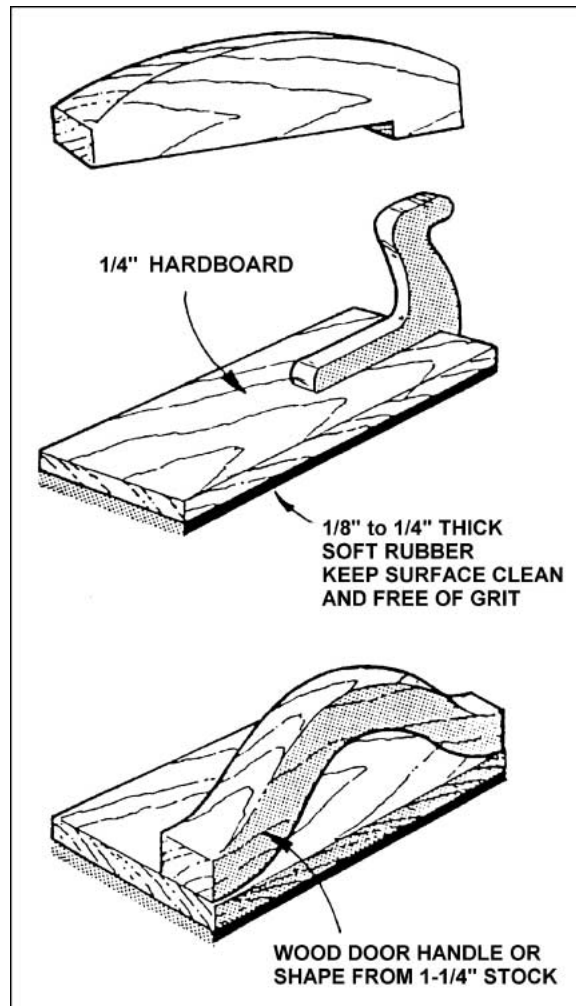

Figure 29

Direction of Grain

Avoid feeding work into the jointer against the grain. This will result in chipped and splintered edges. See Figure 30. Feed *with* the grain to obtain a smooth surface, as shown in Figure 31.

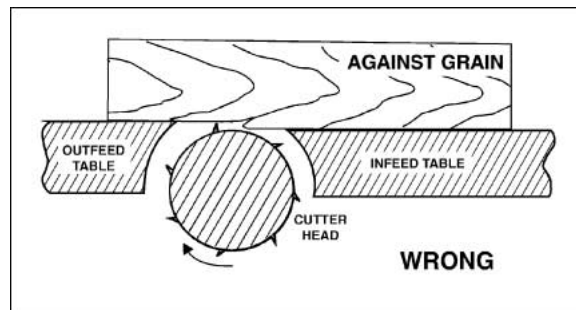

Figure 30

Beveling

To cut a bevel, lock the fence at the required angle and run the workpiece across the knives while keeping it firmly against the fence and tables. Several passes may be necessary to achieve the desired result.

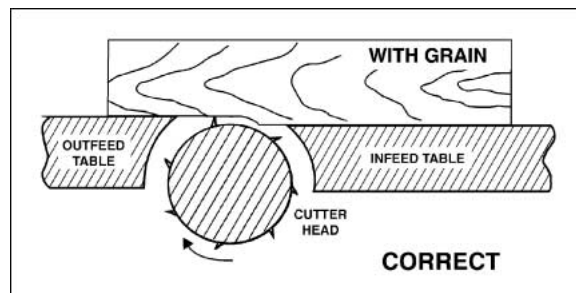

Figure 30

While the fence can be tilted in or out for bevel cutting, it is recommended for safety reasons that the fence be tilted in toward the operator, if possible, making a cradled cut.

Maintenance

⚠WARNING Disconnect machine from power source before performing any maintenance. Failure to comply may cause serious injury.

Check all screws and fasteners occasionally and keep them tightened securely.

Inspect cords; a cord that is frayed or damaged in any way should be replaced immediately.

The table and fence surfaces must be kept clean and free of rust for best results. Some users prefer a paste wax coating. Another option is talcum powder applied with a blackboard eraser rubbed in vigorously once a week; this will fill casting pores and form a moisture barrier. This method provides a table top that is slick and allows rust rings to be easily wiped from the surface. Important also is the fact that talcum powder will not stain wood or mar finishes as wax pickup does.

Lubrication

The cutterhead runs in two single-row sealed and shielded ball bearings, which are pre-lubricated for life - no maintenance is necessary.

Occasionally apply a good grade of light grease to areas of the jointer where friction may occur, such as when the tables are raised or lowered.

Cutterhead Repairs

The entire cutterhead assembly may be removed for bearing replacement or other cutterhead maintenance procedures. The procedure is identical for both helical and straight cutterheads.

To remove the cutterhead:

1. Disconnect machine from power source.
2. Remove rabbeting ledge and fence.
3. Lower infeed and outfeed tables until they are clear of the cutterhead.
4. Remove belts.
5. Remove the two hex cap screws and lock washers that hold the cutterhead to the bed - these are accessed from the underside of the bearing blocks as shown in Figure 32.

⚠WARNING Before removing cutterhead, wrap it with several cloths to prevent personal injury.

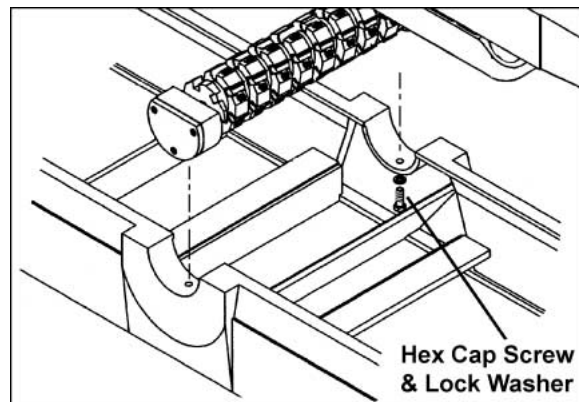

Figure 32

6. Slide the cutterhead out the rabbeting side.
7. Loosen hex cap screw (A, Figure 33) and remove pulley (B, Figure 33) and key (C, Figure 33).
8. Loosen screws (D, Figure 33) on both sides and remove bearing cap plates (E, Figure 33).

NOTE: Figure 33 shows the pulley end of the cutterhead. The procedure is similar for breaking down the opposite end of the cutterhead - refer to assembly drawing on page 39 for the specific parts.

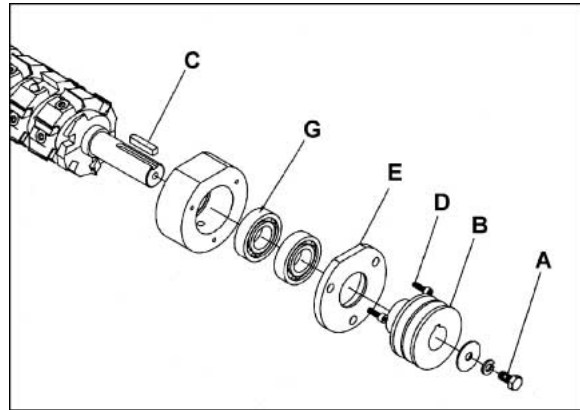

Figure 33

IMPORTANT: If the bearings (G, Figure 33) need replacement, it is strongly recommended this be done by qualified service personnel. The bearings are press fitted and must be removed with an arbor press.

9. To re-install the cutterhead, reverse the above procedure. NOTE: Before re-installing, make sure the machine's curved seats of the base casting are free of dirt, dust or grease, which will help ensure a tight fit.

Knife Inserts (Helical Cutterhead)

When knife inserts become dull enough so that it is noticeable when cutting, they should be turned over or replaced entirely. A sharp knife works easier and results in longer blade life. The penalty paid for a dull knife is less blade life and greater wear and tear on all parts of the machine.

An advantage of the helical style cutterhead is that if knife inserts develop nicks, these inserts can be individually flipped or replaced without the need to disturb the other inserts. See "Replacing Knife Inserts (Helical Cutterhead)" for this procedure.

If the jointer is used often, keeping a spare set of knife inserts on hand is recommended. Knife inserts (stock no. 6400013) may be ordered from your authorized Powematic distributor or by calling 1-800-274-6848.

Gum and pitch which collect on the knife inserts cause excessive friction as the work continues, resulting in overheating of the inserts, less efficient cutting, and consequent loss of blade life. Use "Gum and Pitch Remover" or oven cleaner, to carefully wipe off the knife inserts.

CAUTION Jointer knife inserts are very sharp. Use care and proceed slowly when working with or around the cutterhead.

Whetting Knives (Straight Cutterhead)

When knives become dull enough so that it is noticeable when cutting, they should be resharpened or replaced. A sharp knife will work easier and last longer. The penalty paid for a dull knife is less blade life and greater wear and tear on all parts of the machine.

CAUTION Jointer knives are very sharp. Use care and proceed slowly when working with or around the cutterhead.

1. Disconnect machine from power source.
2. Remove the pulley cover so you can rotate the cutterhead by means of the belts.
3. Use a fine carborundum stone. Cover it partly with paper, as shown in Figure 34, to avoid marking the table.
4. Lay the stone on the infeed table. Adjust the infeed table and turn the cutterhead until the stone lies flat on the bevel of the knife and flat on the infeed table.
5. Hold the cutterhead from turning, and whet the beveled edge of the knife, stroking lengthwise by sliding the stone back and forth across the table. Do the same amount of whetting on each of the three knives.
6. When finished, reset the knives parallel to the outfeed table. See "Setting Knives (Straight Cutterhead)".

If knives cannot be properly retouched as described above, they must be ground and resurfaced to a new bevel edge. Check in the phone directory under "Sharpening Service" or "Tool Grinding or Sharpening." It may be less expensive to purchase a new set of knives. If the jointer is used often, keeping a spare set of knives on hand is recommended.

Knives (stock no. 6292535) may be ordered from your authorized Powermatic distributor or by calling 1-800-274-6848.

Gum and Pitch which collect on the knives cause excessive friction as the work continues, resulting in overheating of the knives, less efficient cutting, and consequent loss of blade life. Use "Gum and Pitch Remover" or oven cleaner, to carefully wipe off the knives.

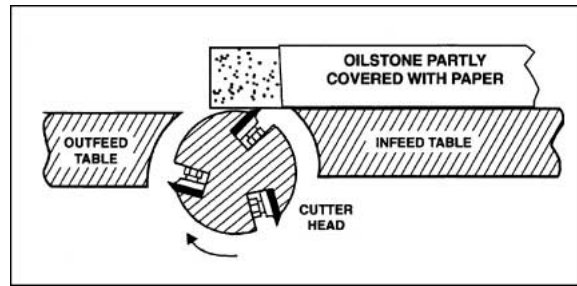

Figure 34

Troubleshooting – Operating Problems

Trouble	Probable Cause	Remedy
Finished stock is concave on back end.	Knife is higher than outfeed table.	Raise outfeed table until it aligns with tip of knife. (see page 13)
Finished stock is concave on front end.	Outfeed table is higher than knife.	Lower outfeed table until it aligns with tip of knife. (see page 13)
Finished stock is concave in the middle.	Both tables have too much end fall.	Raise both table ends using the adjustment screws below the tables (see Figure 35). <div data-bbox="954 548 1425 879" data-label="Image"> </div> <p style="text-align: center;"><i>Figure 35</i></p>
Ends of finished stock are cut more than the middle.	Table ends are raised higher than the middle.	Lower both table ends using the adjustment screws under the tables (see Figure 35).
Chip out.	Cutting against the grain.	Cut with the grain whenever possible.
	Dull knives/inserts.	Sharpen or replace knives/inserts.
	Feeding workpiece too fast.	Use slower rate of feed.
	Cutting too deeply.	Make shallower cuts.
	Knots, imperfections in wood.	Inspect wood closely for imperfections; use different stock if necessary.
Fuzzy grain.	Wood has high moisture content.	Allow wood to dry or use different stock.
	Dull knives/inserts.	Sharpen or replace knives/inserts.
Cutterhead slows while operating.	Feeding workpiece too quickly, or applying too much pressure to workpiece.	Feed more slowly, or apply less pressure to workpiece.
“Chatter” marks on workpiece.	Knife/inserts incorrectly set.	Set knives properly using provided knife setting gauge (straight cutterhead only – see page 15). Check that insert slots are clean and free of dust or debris (helical cutterhead only).
	Feeding workpiece too fast.	Feed workpiece slowly and consistently.

Trouble	Probable Cause	Remedy
Uneven knife marks on workpiece.	Knives/inserts are knicked, or out of alignment.	Replace knicked knives/inserts; align knives properly with knife-setting gauge (straight cutterhead only).

Troubleshooting – Mechanical and Electrical Problems

Trouble	Probable Cause	Remedy
Machine will not start/restart or repeatedly trips circuit breaker or blows fuses.	No incoming power.	Verify unit is connected to power, and on-switch is pushed in completely.
	Overload automatic reset has not reset.	When jointer overloads on the circuit breaker built into the motor starter, it takes time for the machine to cool down before restart. Allow unit to adequately cool before attempting restart. If problem persists, check amp setting on the motor starter inside the electrical enclosure.
	Jointer frequently trips.	One cause of overloading trips which are not electrical in nature is too heavy a cut. The solution is to take a lighter cut. If too deep a cut is not the problem, then check the amp setting on the overload relay. Match the full load amps on the motor as noted on the motor plate. If amp setting is correct then there is probably a loose electrical lead. Check amp setting on motor starter.
	Building circuit breaker trips or fuse blows.	Verify that jointer is on a circuit of correct size. If circuit size is correct, there is probably a loose electrical lead. Check amp setting on motor starter.
	Motor starter failure.	If you have access to a voltmeter, you can separate a starter failure from a motor failure by first, verifying incoming voltage at 220+/-20 and second, checking the voltage between starter and motor at 220+/-20. If incoming voltage is incorrect, you have a power supply problem. If voltage between starter and motor is incorrect, you have a starter problem. If voltage between starter and motor is correct, you have a motor problem.
	Motor overheated.	Clean motor of dust or debris to allow proper air circulation. Allow motor to cool down before restarting.

Trouble	Probable Cause	Remedy
	Motor failure.	If electric motor is suspect, you have two options: Have a qualified electrician test the motor for function or remove the motor and take it to a qualified electric motor repair shop and have it tested.
	Miswiring of the unit.	Double check to confirm all electrical connections are correct and properly tight. The electrical connections other than the motor are pre-assembled and tested at the factory. Therefore, the motor connections should be double checked as the highest probability for error. If problems persist, double check the factory wiring.
	On/off switch failure.	If the on/off switch is suspect, you have two options: Have a qualified electrician test the switch for function, or purchase a new on/off switch and establish if that was the problem on changeout.

Optional Accessories

6292535	12" Jointer Knives (set of 3)
6400013	Carbide Insert Knives for Helical Head (set of 10)
PJ1696-011	Rabbit Inserts for Helical Head (set of 2)
PJ1285-109	Contactors, 3Ph, 460V
6285917	Push Block

Replacement Parts

Replacement parts are listed on the following pages. To order parts or reach our service department, call 1-800-274-6848 between 7:00 a.m. and 6:00 p.m. (CST), Monday through Friday. Having the Model Number and Serial Number of your machine available when you call will allow us to serve you quickly and accurately.

Parts List: Stand Assembly

Index No.	Part No.	Description	Size	Qty
1	PJ1285-101	Stand		1
2	TS-0680041	Flat Washer	3/8"	4
3	TS-0720091	Lock Washer	3/8"	4
4	TS-0060051	Hex Cap Screw	3/8"-16x1"	4
5	6292491	Cover, Dust Chute		1
6	TS-081C022	Machine Screw, Pan Head, Phillips	#10-24x3/8"	5
7	6292493	Motor Assembly, Motor With Pulley	3HP, 3Ph	1
	6295366	Motor Assembly, Motor With Pulley	3HP, 1Ph	1
8	6292494	Plate, Switch		1
9	6295112	Contactor	1Ph	1
	6292495	Contactor	3Ph, 230V	1
	PJ1285-109	Contactor	3Ph, 460V	1
10	PJ1285-110	Clamp	3Ph	3
	PJ1285-110A	Clamp	1Ph	3
11	6292497	Box, Junction		1
12	6292498	Strip, Terminal		1
13	TS-081C062	Machine Screw, Pan Head, Phillips	#10-24x1"	2
14	TS-0720051	Lock Washer	#10	2
15	PJ1696-211	Switch		1
16	PJ1285-116	Hood, Dust		1
17	TS-0720071	Lock Washer	1/4"	9
18	TS-0050011	Hex Cap Screw	1/4"-20x1/2"	7
19	6292507	Cover, Pulley		1
20	6292508	Bolt		3
22	TS-0561031	Hex Nut	3/8"-16	6
23	TS-059303	Cap Nut	3/8"-16	3
24	6292510	Door, Access		1
25	6292511	Hand Assembly		1
26	PJ1285-126	Washer	3/8"x3/4 OD	1
27	PJ1696-210	Switch Arm		1
28	TS-1533052	Machine Screw, Pan Head, Phillips	M5x16	2
29	PJ1285-129	Switch Cord		1
30	PJ1285-130	Motor Cord	1Ph	1
	PJ1285-130A	Motor Cord	3Ph	1
31	PJ1285-131	Power Cord	1Ph	1
	PJ1285-131A	Power Cord	3Ph	1
32	3312341	Powermatic Logo		1

Stand Assembly

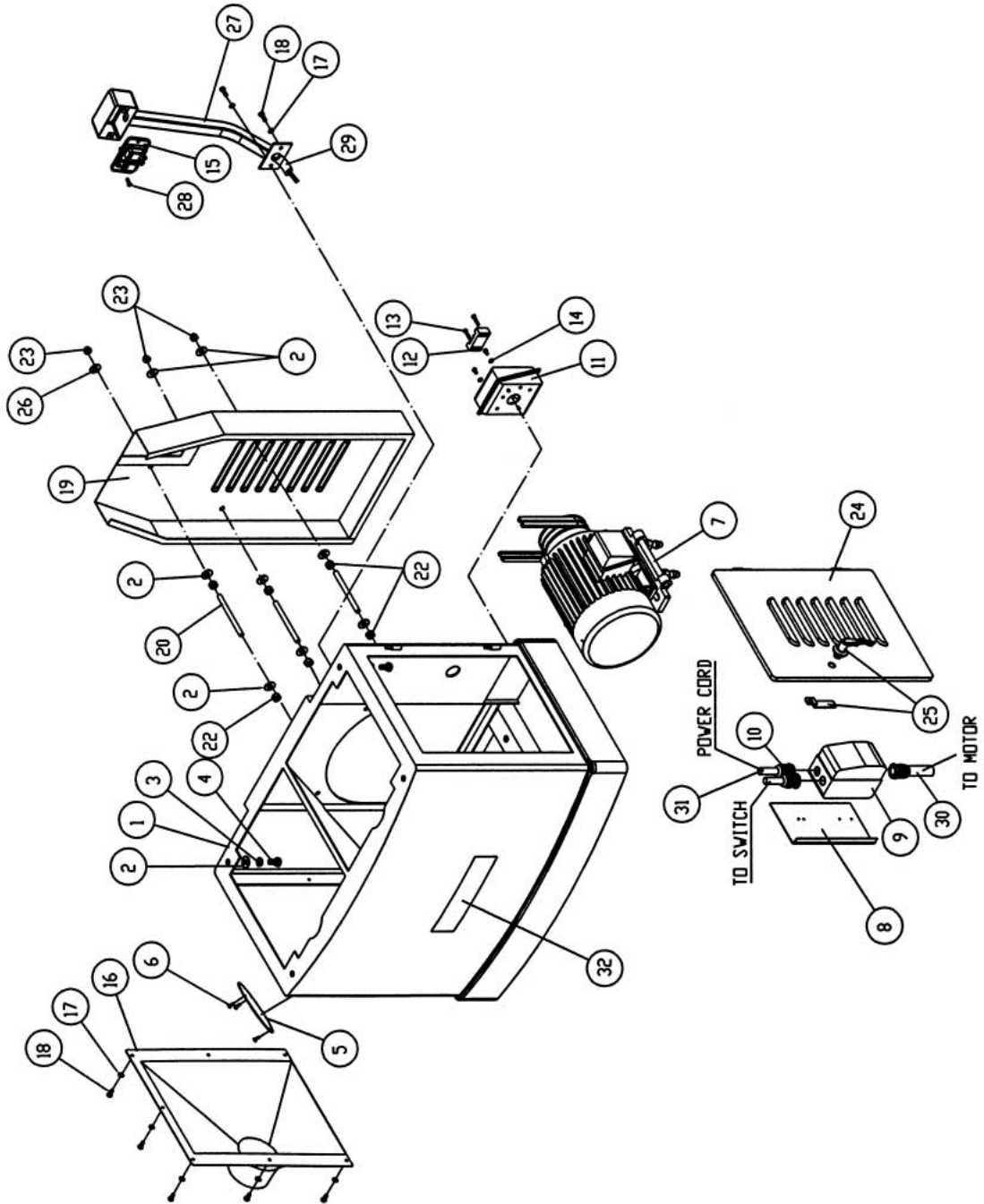

Parts List: Table Assembly

Index No.	Part No.	Description	Size	Qty
1	6292525	Base		1
2	6292526	Bar, Table Raising Link		2
3	6292527	Bracket		2
4	TS-0680041	Lock Washer	3/8"	8
5	TS-0209051	Socket Head Cap Screw	3/8"-16x1"	4
6	6292530	Bushing		8
7	6292531	Support		8
8	6292532	Bushing		8
9	6292533	Axis, Pivot		4
10	6292534	Screw		2
11	TS-0680061	Flat Washer	1/2"	2
12	6292536	Handwheel		2
13	6292537	Handle		2
14	TS-0209061	Socket Head Cap Screw	3/8"-16x1-1/4"	4
15	TS-1490041	Hex Cap Screw	M8x25	2
16	TS-1540061	Hex Nut	M8	4
17	6292540	Knob		2
18	6292541	Axis, Pivot		8
19	TS-0208071	Socket Head Cap Screw	5/16"-18x1-1/4"	8
20	6292543	Bar, Table Raising Link		2
21	6292544	Axis, Pivot		4
22	6292545	Screw		8
23	TS-0561031	Hex Nut	3/8"-16	24
24	6292547	Tube		2
25	6292548	Spring		4
26	PJ1696-509	Spring Holding Bolt		4
27	6292550	Straight Cutterhead Assembly		1
	PJ1285-600	Helical Cutterhead Assembly		1
28	TS-1491041	Hex Cap Screw	M10x30	2
29	6292551	Infeed Table		1
30	6292552	Lip, Table		1
31	TS-1505061	Socket Head Cap Screw	M10x40	8
32	6292554	Deflector, Dust		1
33	TS-081C062	Machine Screw, Pan Head, Phillips	#10-24x1"	5
34	TS-0680011	Flat Washer	3/16"	5
35	TS-0560071	Hex Nut	#10-24	5
36	6292558	Outfeed Table		1
37	6292559	Lip, Table		1
38	6292560	Guard Assembly		1
39	TS-2361101	Lock Washer	M10	2
40	PJ1285-240	Pointer		1
41	PJ1285-241	Scale		1
42	TS-0680011	Flat Washer	3/16"	1
43	TS-081C022	Machine Screw, Pan Head, Phillips	#10-24x3/8"	1
44	TS-0680041	Flat Washer	3/8"	24
45	TS-0271051	Socket Set Screw	3/8"-16x1/2"	4
46	TS-0271031	Socket Set Screw	3/8"-16x3/8"	4
47	TS-0561011	Hex Nut	1/4"-20	4
48	6285917	Push Block		2
49	PJ1285-249	Set Screw	M8x35	2

Table Assembly

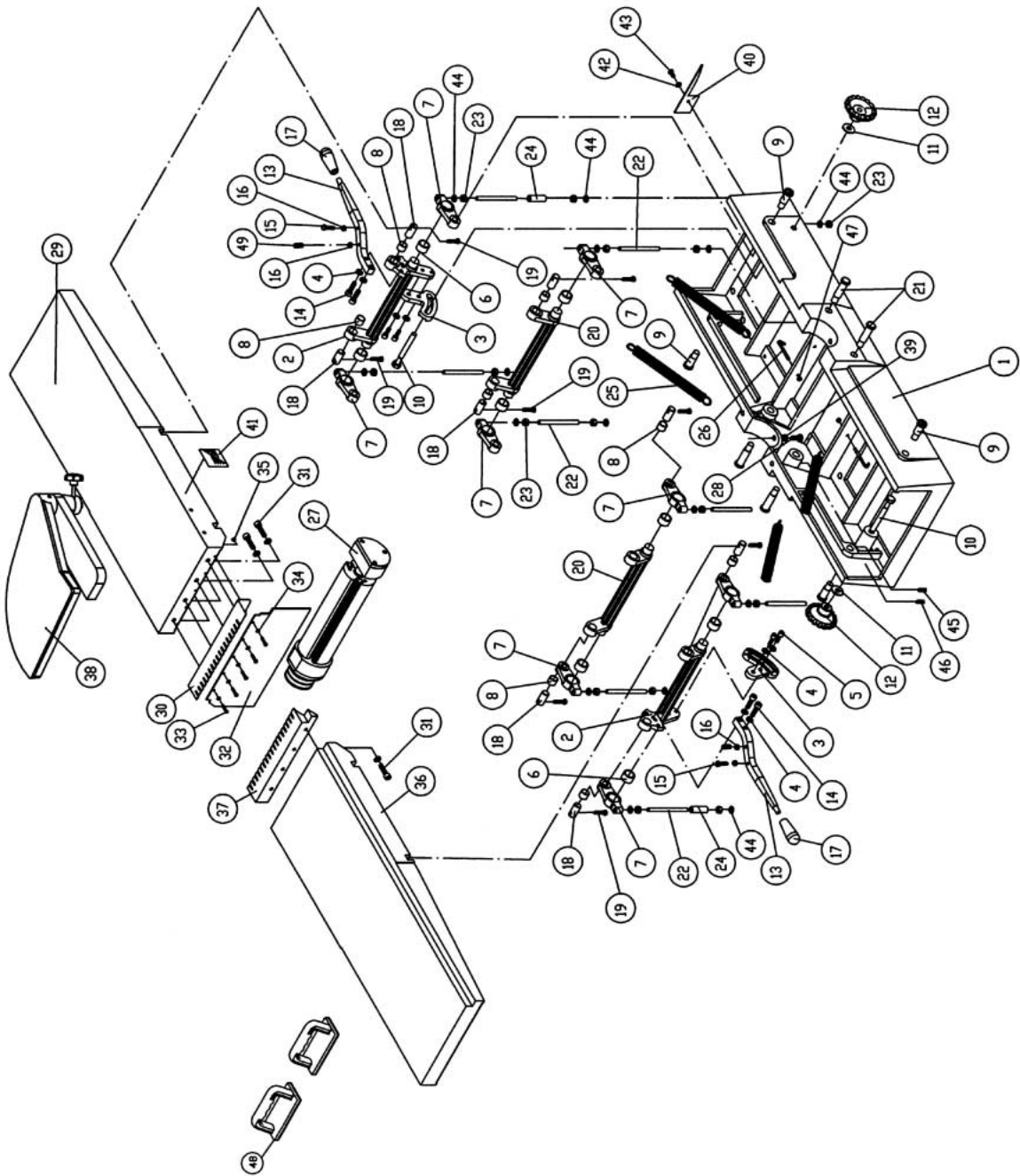

Parts List: Motor Pulley Assembly

Index No.	Part No.	Description	Size	Qty
1	6292512	Motor	3HP 3Ph	1
	6292512-MF	Motor Fan (not shown)		1
	6292512-MFC	Motor Fan Cover (not shown)		1
	6292563	Motor	3HP 1Ph	1
	6292563-MF	Motor Fan (not shown)		1
	6292563-MFC	Motor Fan Cover (not shown)		1
	6292563-CS	Centrifugal Switch (not shown)		1
	6292563-SC	Starting Capacitor (not shown)	400MFD, 250VAC	1
	6292563-RC	Running Capacitor (not shown)	50uf, 350VAC	1
2	6292513	Pulley	3Ph	1
	6294246	Pulley	1Ph	1
3	TS-1525011	Socket Screw Screw	M10x10	1
4	6292515	Bracket, Motor		1
5	TS-0680041	Flat Washer	3/8"	3
6	TS-0720091	Lock Washer	3/8"	6
7	TS-0060081	Hex Cap Screw	3/8"-16x1-3/4"	3
8	TS-0561031	Hex Nut	3/8"-16	3
9	6292520	Plate		1
10	6292521	Rod		1
11	TS-2360121	Flat Washer	M12	2
12	TS-1540081	Hex Nut	M12	8
13	TS-1525021	Socket Set Screw	M10x12	1
14	6295367	Belt, 1PH	A-53	2
	6295357	Belt, 3PH	A-55	2
15	PJ1285-315	Key	8mmx 7mm x 55mm	1

Motor Pulley Assembly

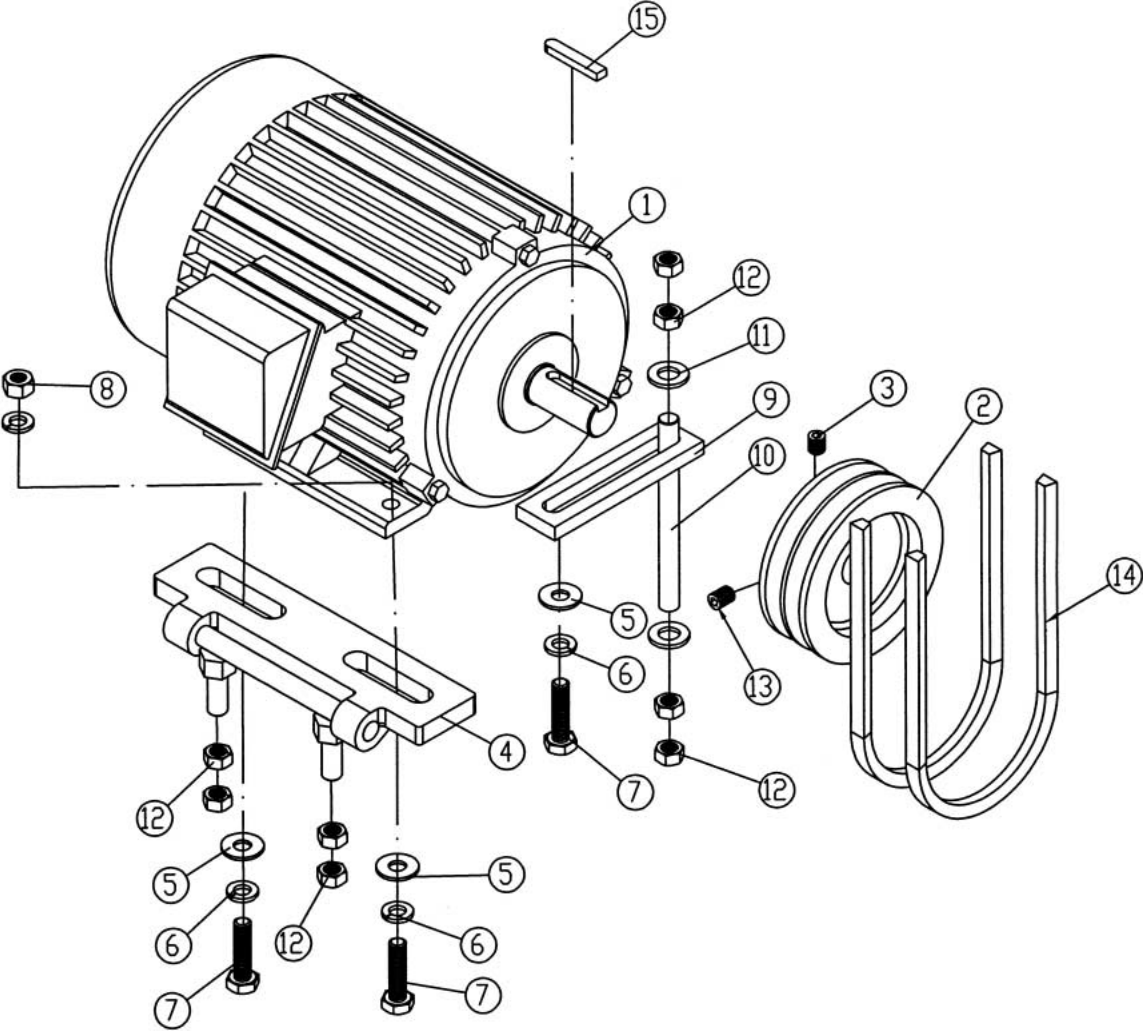

Parts List: Cutterhead Guard Assembly

Index No.	Part No.	Description	Size	Qty
1	6292581	Ledge, Rabbet		1
2	6292582	Guard		1
3	6292583	Shaft		1
4	6292584	Spring		1
5	6292585	Collar, Shaft		1
6	TS-0271071	Socket Set Screw	3/8"-16x3/4"	1
7	TS-0267071	Socket Set Screw	1/4"-20x3/4"	2
8	TS-0561011	Hex Nut	1/4"-20	2
9	6292589	Knob		1
10	TS-0720091	Lock Washer	3/8"	2
11	TS-0209031	Socket Head Cap Screw	3/8"-16x3/4"	2
12	TS-0680041	Flat Washer	3/8"	2
13	60B-272	Warning Label		1

Cutterhead Guard Assembly

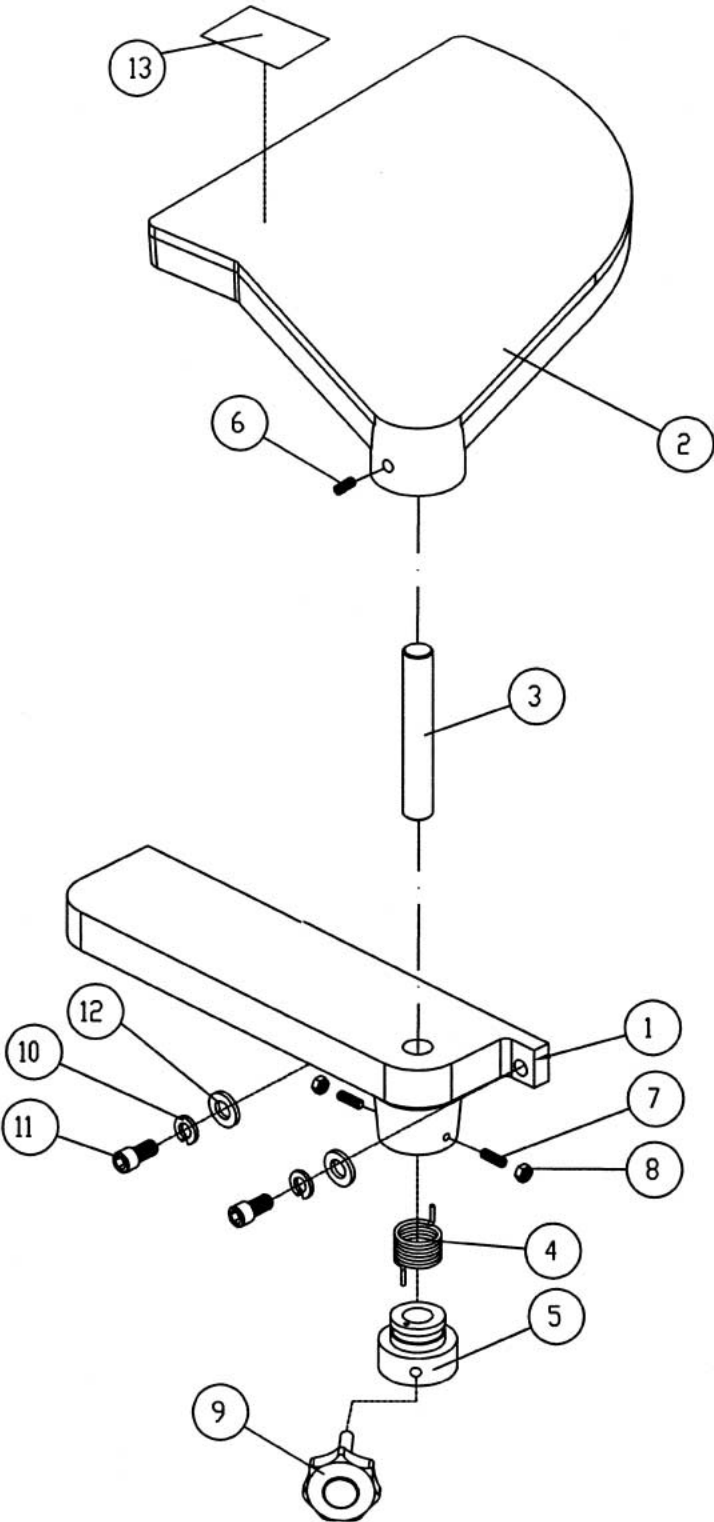

Parts List: Straight Cutterhead Assembly

Index No.	Part No.	Description	Size	Qty
	6292550	Cutterhead Assembly (Items 1 thru 19)		1
1	6292561	Cutterhead		1
2	PJ1696-002	Left Bearing Housing		1
3	BB-6204ZZ	Bearing	6204ZZ	2
4	PJ1696-005	Right Bearing Housing		1
5	BB-6206ZZ	Bearing	6206ZZ	2
6	6292566	Bearing Washer		1
7	TS-1490031	Hex Cap Screw	M8x20	1
8	TS-1503051	Socket Head Cap Screw	M6x20	6
9	6292572	Pulley		1
10	6292573	Key	8mmx8mmx60mm	1
11	6292574	Pulley Washer		1
12	TS-2361101	Lock Washer	M10	1
13	TS-1491021	Hex Cap Screw	M10x20	1
14	6292577	Spring		6
15	6292535	Knife (set of 3)		1
16	6292579	Gib, Knife (set of 3)		1
17	6292580	Gib Screw		18
18	PJ1696-004	Left Bearing Cap Plate		1
19	PJ1696-006	Right Bearing Cap Plate		1
	PJ1285-KSGA	Knife Setting Gauge Assembly (Items 20 thru 23)		1
20	PJ1285-520	Handle		1
21	PJ1285-521	Setting Gauge		2
22	TS-1482051	Hex Cap Screw	M6x25	2
23	TS-2361061	Lock Washer	M6	2

Straight Cutterhead Assembly

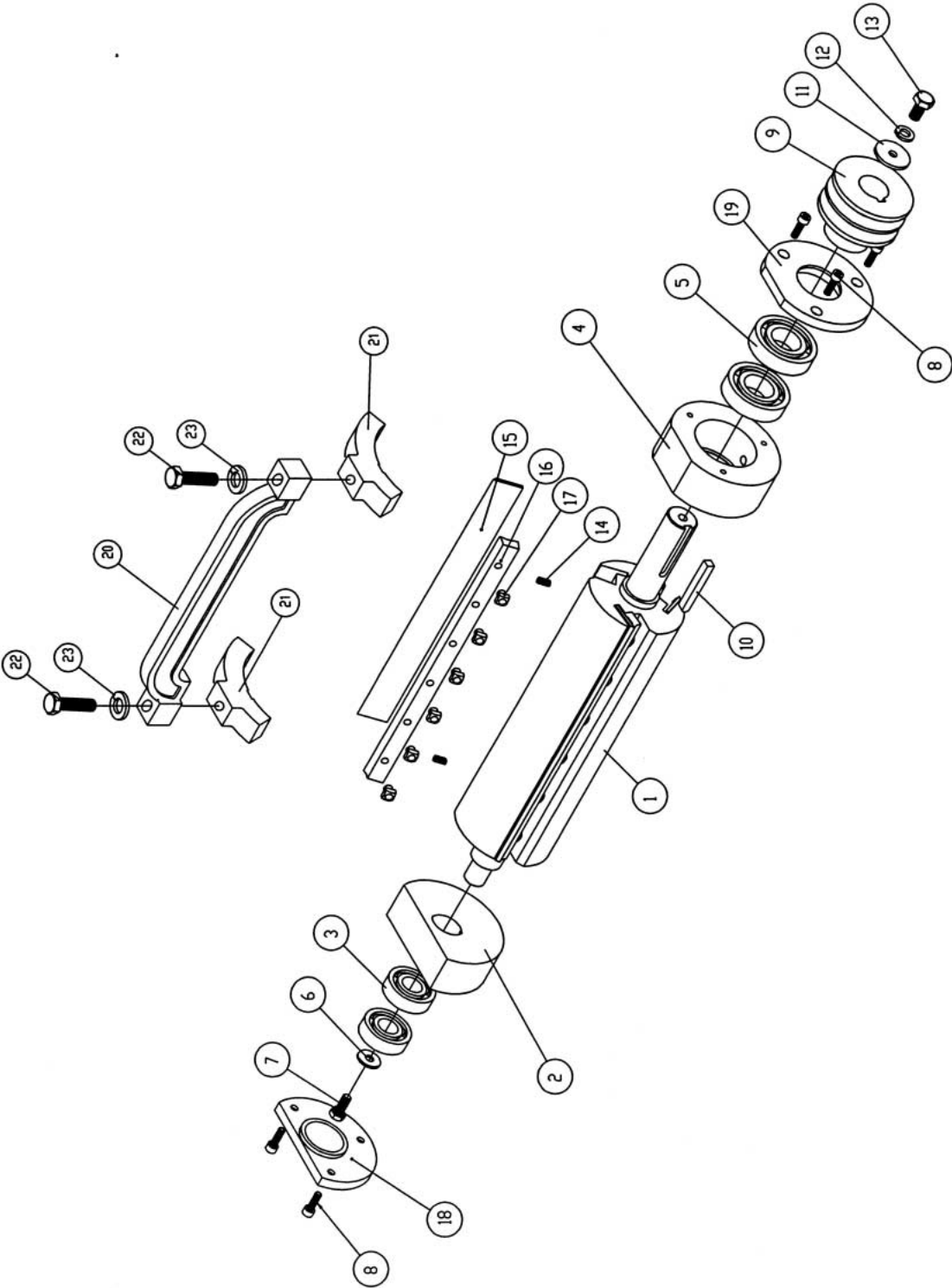

Parts List: Helical Cutterhead Assembly

Index No.	Part No.	Description	Size	Qty
	PJ1285-600	Cutterhead Assembly (Items 1 thru 22)		
1	PJ1285-601	Cutterhead		1
2	PJ1696-002	Left Bearing Housing		1
3	BB-6204ZZ	Ball Bearing	6204ZZ	2
4	6292566	Bearing Washer		1
6	TS-1490031	Hex Cap Screw	M8x20	1
7	PJ1696-004	Left Bearing Cap Plate		1
8	TS-1503051	Socket Head Cap Screw	M6x1.0Px20L	6
9	PJ1696-005	Right Bearing Housing		1
10	BB-6206ZZ	Bearing	6206ZZ	2
11	PJ1696-006	Right Bearing Cap Plate		1
12	6292573	Key	8mm x 8mm x 60mm	1
13	6292572	Cutterhead Sheave		1
14	6292574	Pulley Washer		1
15	TS-2361101	Lock Washer	M10	1
16	TS-1491021	Hex Cap Screw	M10x20	1
17	PJ1696-010	Gib		46
18	PJ1696-011	Carbide Insert Knife-Rabbit (Sold in pkg of 2)		2
19	6400013	Carbide Insert Knife (Sold in pkg of 10)		44
20	PJ1696-012	Gib Nut		46
21	PJ1696-013	Gib Screw		46
22	PJ1696-015	Gib Pin	Ø 2x 8	92

Helical Cutterhead Assembly

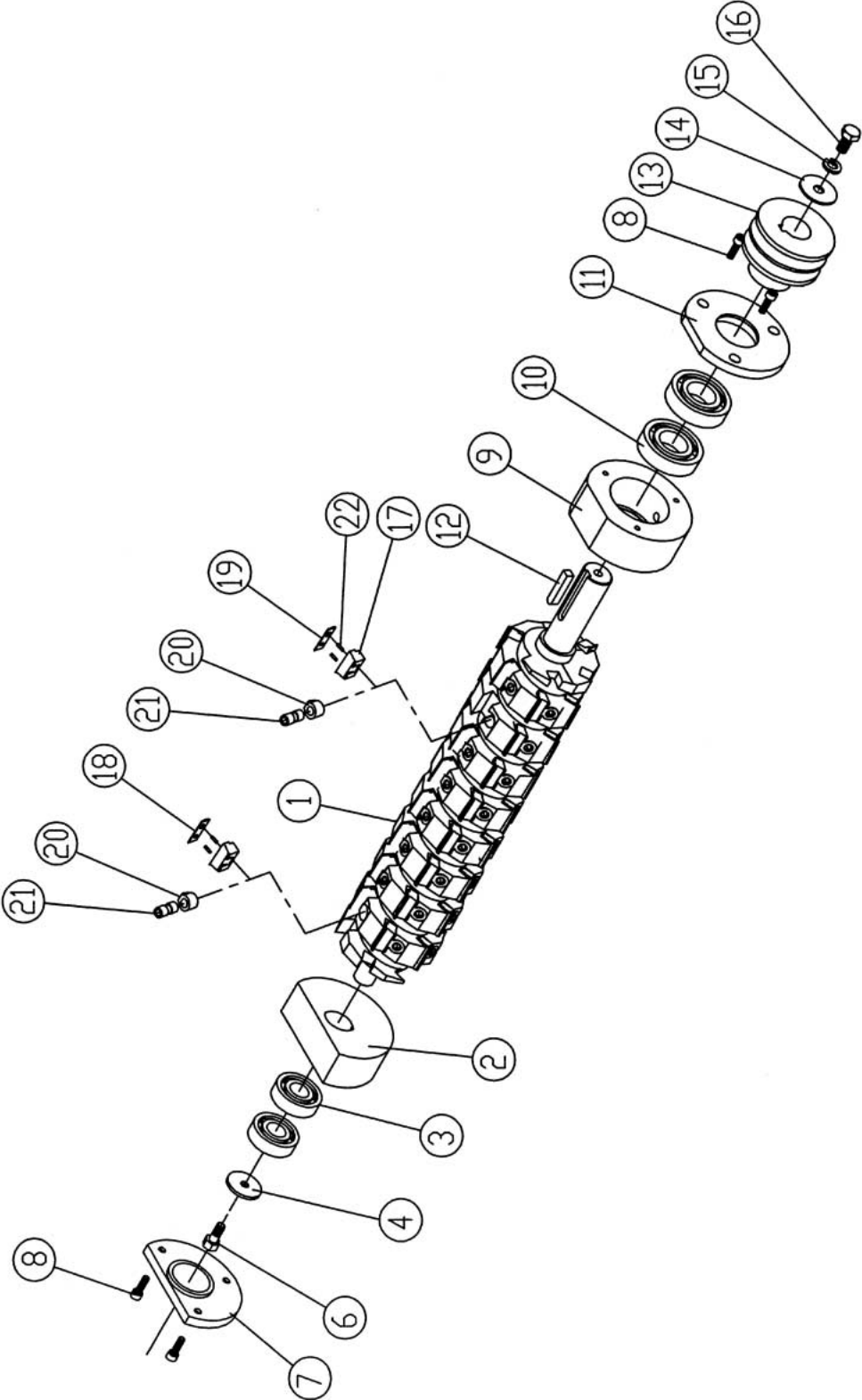

Parts List: Fence Assembly

Index No.	Part No.	Description	Size	Qty
1	6292592	Support, Fence		1
2	6292593	Bracket		1
3	6292594	Column, Gear		1
4	6292595	Guard		1
5	TS-1503031	Socket Head Cap Screw	M6x12	2
6	TS-1550071	Flat Washer	M10	4
7	TS-2361101	Lock Washer	M10	4
8	TS-1491041	Hex Head Bolt	M10x30	2
9	TS-1505041	Socket Head Cap Screw	M10x30	2
10	6292601	Shaft, Gear		1
11	6292602	Handwheel		1
12	6292603	Lock Handle		1
13	6295358	Collar		1
14	6292604	Bolt		1
15	TS-0720111	Lock Washer	1/2"	2
16	6295886	Socket Head Cap Screw	1/2"-12NCx1-1/4"	2
17	6292605	Bracket, Fence		1
18	6292606	Support		1
19	6292607	Pin		6
20	TS-1523061	Socket Set Screw	M6x20	2
21	TS-1540061	Hex Nut	M8	4
22	TS-1490031	Hex Cap Screw	M8x20	2
23	6292611	Bracket, Left		1
24	6292612	Bracket, Right		1
25	6292613	Shaft		1
26	TS-2360121	Flat Washer	M12	2
27	6292615	Lock Handle		1
28	TS-2331121	Cap Nut	M12	1
29	6292823	Spring Pin	Ø5x20	1
30	6295359	Clamp, Rear		2
31	6295360	Fence		1
32	TS-1540081	Hex Nut	M12	1
33	6295362	Rod		1
34	6292540	Knob		1
35	6295364	Block		1
36	6295365	Bushing		1
37	TS-2361081	Lock Washer	M8	1
38	TS-1490061	Hex Cap Screw	M8x35	1
39	PJ1285-739	Cover		1
40	PJ1696-105	Block		1
41	TS-1501051	Socket Head Cap Screw	M4x16	1
42	TS-1523041	Socket Set Screw	M6x12	1
43	TS-1540071	Hex Nut	M10	1
44	TS-1550061	Flat Washer	M8	1
45	TS-1490061	Hex Cap Screw	M8x35	2
46	TS-1505021	Socket Head Cap Screw	M10x20	4

Fence Assembly

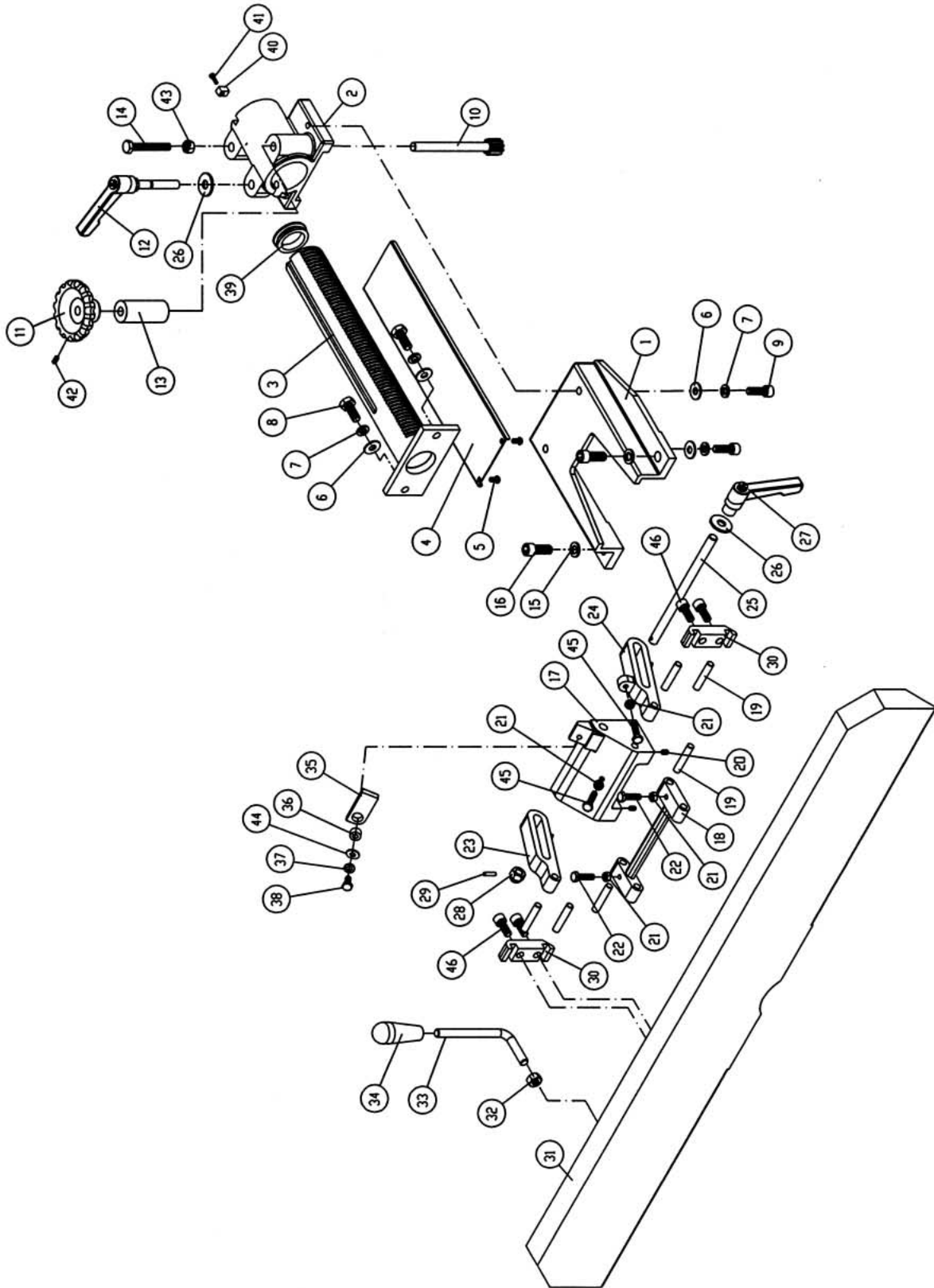

Electrical Connections – 1 Phase

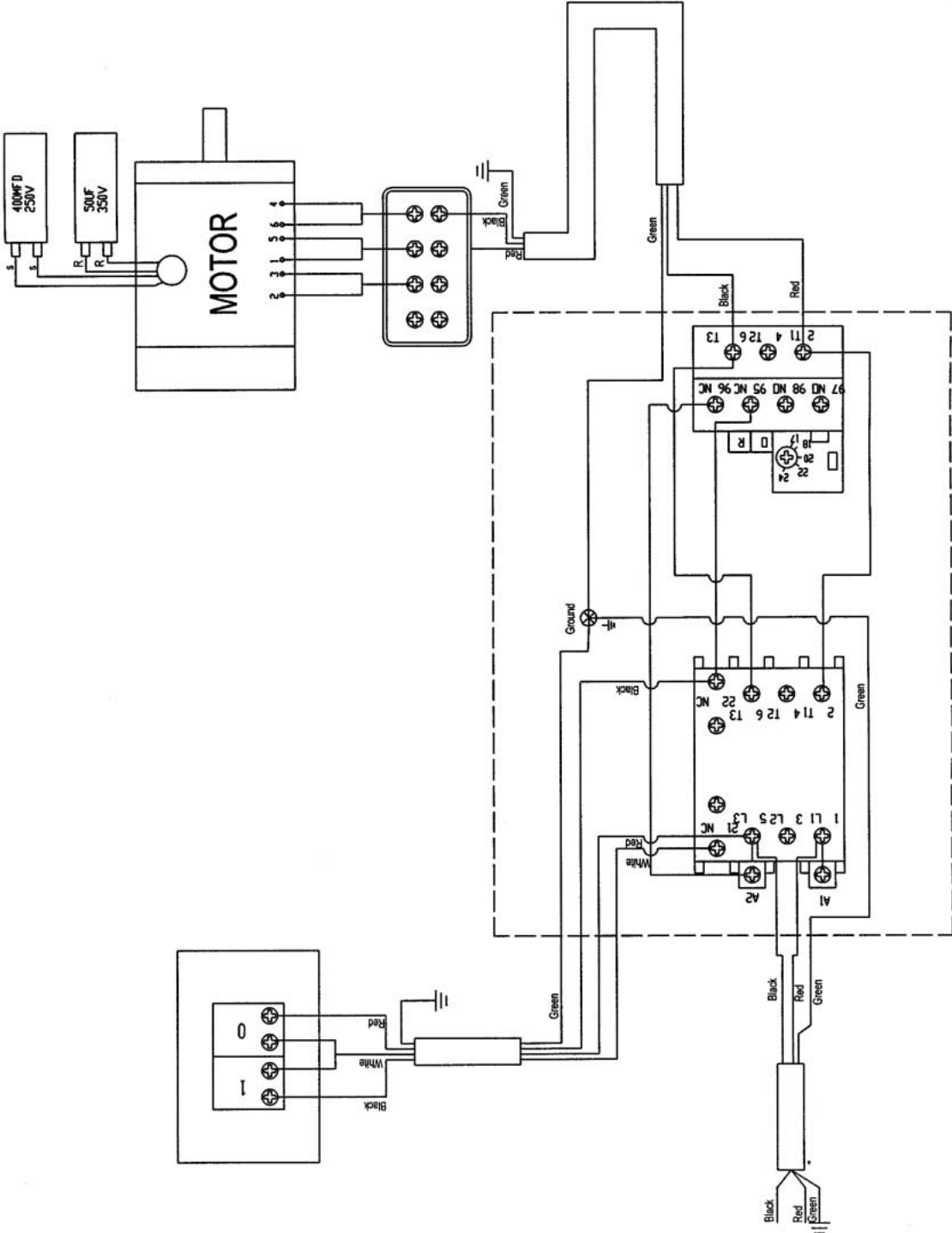

Electrical Connections – 3 Phase

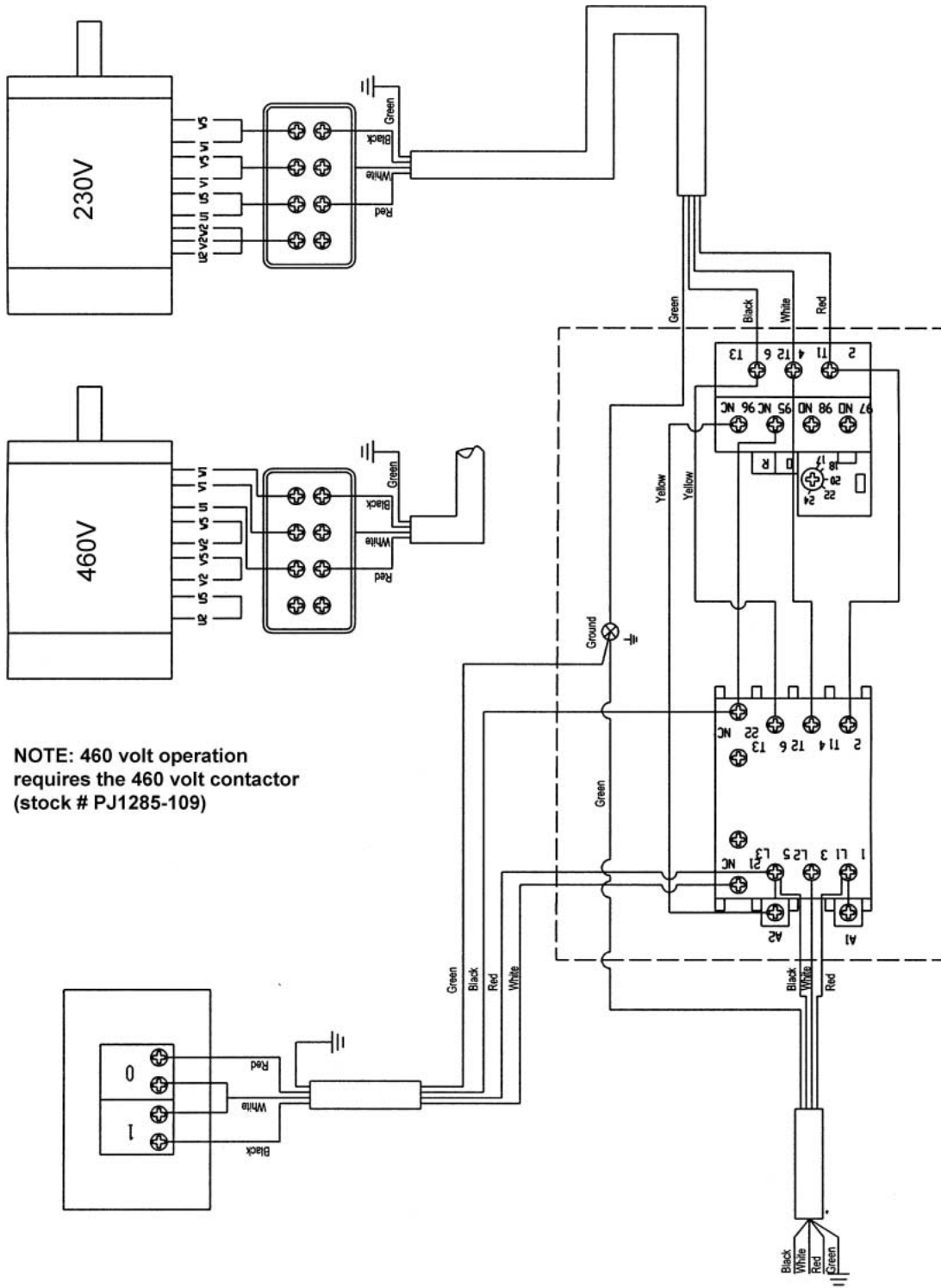

NOTE: 460 volt operation requires the 460 volt contactor (stock # PJ1285-109)

POWERMATIC[®]

WMH Tool Group
2420 Vantage Drive
Elgin, Illinois 60123
Phone: 800-274-6848
www.wmhtoolgroup.com