

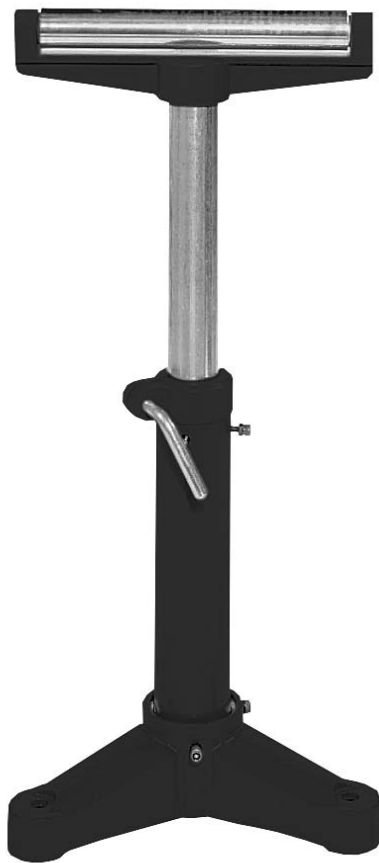

# Operating Instructions and Parts Manual Material Support Stands

Support Stand Models SSH and SSVH  
Roller Head Models SSHHO and SSVHO



**WALTER MEIER (Manufacturing) Inc.**

427 New Sanford Road  
LaVergne, Tennessee 37086  
Ph.: 800-274-6848  
[www.waltermeier.com](http://www.waltermeier.com)

**Part No. M-414121**  
Revision A 12/2010

Copyright © 2010 Walter Meier (Manufacturing) Inc.

# Warranty and Service

Walter Meier (Manufacturing) Inc., warrants every product it sells. If one of our tools needs service or repair, one of our Authorized Service Centers located throughout the United States can give you quick service. In most cases, any of these Walter Meier Authorized Service Centers can authorize warranty repair, assist you in obtaining parts, or perform routine maintenance and major repair on your JET® tools. For the name of an Authorized Service Center in your area call 1-800-274-6848.

## MORE INFORMATION

Walter Meier is consistently adding new products to the line. For complete, up-to-date product information, check with your local Walter Meier distributor, or visit [waltermeier.com](http://waltermeier.com).

## WARRANTY

JET products carry a limited warranty which varies in duration based upon the product (MW = Metalworking, WW = Woodworking).

<b>90</b> DAY WARRANTY	<b>1</b> YEAR WARRANTY	Body Repair Kits Bottle Jacks Cable Pullers Cold Saws Hoists-Air Hoists-Electric Metal forming Mill/Drills Milling Machines MW Bandsaws MW Drill Presses MW Finishing Equipment MW Lathes MW Precision Vises	<b>2</b> YEAR WARRANTY	Palet Trucks Rigging Equip. Service Jacks Stackers Surface Grinders Tapping Trolleys-Air Trolleys-Electric Web Slings Winches-Electric	<b>3</b> YEAR WARRANTY	WW Benchtop Tools	<b>5</b> YEAR WARRANTY	Beam Clamps Chain Hoist-Manual Lever Hoists Pullers-JCH Models Scissor Lift Tables Screw Jacks Trolleys-Geared Trolleys-Plain Winches-Manual WW Air Filtration WW Bandsaws WW Buffers	WW Drill Presses WW Dust Collectors WW Dust Filters WW Dust Fittings WW Jointers WW Lathes WW Planers WW Sanders WW Shapers WW Tablesaws	<b>LIFE</b> LIFETIME WARRANTY	Fastening Tools Mechanics Hand Tools Striking Tools Vises (no -precision) Clamps
<i>Warranty reverts to 1 Year Warranty if woodworking (WW) products listed above are used for industrial or educational purposes.</i>											

## WHAT IS COVERED?

This warranty covers any defects in workmanship or materials subject to the exceptions stated below. Cutting tools, abrasives and other consumables are excluded from warranty coverage.

## WHO IS COVERED?

This warranty covers only the initial purchaser of the product.

## WHAT IS THE PERIOD OF COVERAGE?

The general JET warranty lasts for the time period specified in the product literature of each product.

## WHAT IS NOT COVERED?

Five Year Warranties do not cover woodworking (WW) products used for commercial, industrial or educational purposes. Woodworking products with Five Year Warranties that are used for commercial, industrial or education purposes revert to a One Year Warranty. This warranty does not cover defects due directly or indirectly to misuse, abuse, negligence or accidents, normal wear-and-tear, improper repair or alterations, or lack of maintenance.

## HOW TO GET SERVICE

The product or part must be returned for examination, postage prepaid, to a location designated by us. For the name of the location nearest you, please call 1-800-274-6848.

You must provide proof of initial purchase date and an explanation of the complaint must accompany the merchandise. If our inspection discloses a defect, we will repair or replace the product, or refund the purchase price, at our option. We will return the repaired product or replacement at our expense unless it is determined by us that there is no defect, or that the defect resulted from causes not within the scope of our warranty in which case we will, at your direction, dispose of or return the product. In the event you choose to have the product returned, you will be responsible for the shipping and handling costs of the return.

## HOW STATE LAW APPLIES

This warranty gives you specific legal rights; you may also have other rights which vary from state to state.

## LIMITATIONS ON THIS WARRANTY

WALTER MEIER (MANUFACTURING) INC., LIMITS ALL IMPLIED WARRANTIES TO THE PERIOD OF THE LIMITED WARRANTY FOR EACH PRODUCT. EXCEPT AS STATED HEREIN, ANY IMPLIED WARRANTIES OR MERCHANTABILITY AND FITNESS ARE EXCLUDED. SOME STATES DO NOT ALLOW LIMITATIONS ON HOW LONG THE IMPLIED WARRANTY LASTS, SO THE ABOVE LIMITATION MAY NOT APPLY TO YOU.

WALTER MEIER SHALL IN NO EVENT BE LIABLE FOR DEATH, INJURIES TO PERSONS OR PROPERTY, OR FOR INCIDENTAL, CONTINGENT, SPECIAL, OR CONSEQUENTIAL DAMAGES ARISING FROM THE USE OF OUR PRODUCTS. SOME STATES DO NOT ALLOW THE EXCLUSION OR LIMITATION OF INCIDENTAL OR CONSEQUENTIAL DAMAGES, SO THE ABOVE LIMITATION OR EXCLUSION MAY NOT APPLY TO YOU.

Walter Meier sells through distributors only. The specifications in Walter Meier catalogs are given as general information and are not binding. Members of Walter Meier reserve the right to effect at any time, without prior notice, those alterations to parts, fittings, and accessory equipment which they may deem necessary for any reason whatsoever. JET®-branded products are not sold in Canada by Walter Meier.

# Table of Contents

- Warranty and Service ..... 2
- Table of Contents ..... 3
- Warning..... 4
- Specifications ..... 6
- Introduction ..... 7
- Set-up and Use ..... 7
  - Unpacking..... 7
  - Assembly ..... 7
  - Using the Material Support Stand..... 7
  - Adjusting Roller Head Height ..... 7
  - Moving Material on the Rollers ..... 7
- Maintenance..... 8
  - Maintenance of the Rollers..... 8
  - Maintenance of the Inner Column..... 8
- Replacement Parts ..... 8
  - Parts List: V-Roller Material Support Stand (Stock # 414121) ..... 9
  - Parts List: Horizontal Roller Material Support Stand (Stock # 414122) ..... 10



# Warnings

1. Read and understand the entire owners' manual before attempting assembly or operation.
2. Read and understand the warnings posted on the machine and in this manual. Failure to comply with all of these warnings may cause serious injury.
3. Replace the warning labels if they become obscured or removed.
4. This material support stand is designed and intended for use by properly trained and experienced personnel only. If you are not familiar with the proper and safe operation of a material support stand, do not use until proper training and knowledge have been obtained.
5. Do not use this material support stand for other than its intended use. If used for other purposes, Walter Meier (Manufacturing) Inc., disclaims any real or implied warranty and holds itself harmless from any injury that may result from that use.
6. Always wear approved safety glasses/face shields while using this material support stand. Everyday eyeglasses only have impact resistant lenses; they are not safety glasses.
7. Do not operate while tired or under the influence of drugs, alcohol or any medication.
8. Remove adjusting keys and wrenches. Form a habit of checking to see that keys and adjusting wrenches are removed from the area before using the material support stand.
9. Keep safety guards in place at all times when the machine is in use. If removed for maintenance purposes, use extreme caution and replace the guards immediately.
10. Check damaged parts. Before further use a part that is damaged should be carefully checked to determine that it will operate properly and perform its intended function. Check for alignment of moving parts, binding of moving parts, breakage of parts, mounting and any other conditions that may affect its operation. A part that is damaged should be properly repaired or replaced.
11. Provide for adequate space surrounding work area and non-glare, overhead lighting.
12. Keep the floor around the work area clean and free of scrap material, oil and grease.
13. Do not use in a dangerous environment. Don't use power tools in damp or wet locations, or expose them to rain. Keep work area well lighted.
14. Keep visitors a safe distance from the work area. **Keep children away.**
15. Make your workshop child proof with padlocks, master switches or by removing starter keys.
16. Give your work undivided attention. Looking around, carrying on a conversation and "horse-play" are careless acts that can result in serious injury.
17. Use the right tool at the correct speed and feed rate. Do not force a tool or attachment to do a job for which it was not designed. The right tool will do the job better and safer.
18. Use recommended accessories; improper accessories may be hazardous.
19. Maintain tools with care. Follow instructions for lubricating and changing accessories.
20. Secure roller in position. The locking handle must be tight for column clamp to secure the roller in position and support the weight of the material.
21. Do not overload. To handle material that exceeds the weight limit, place additional roller support stands at even intervals over the length of the material.
22. Avoid impact loads. The weight limit of the stands was determined under static loads. Do not drop material on the roller head.
23. Never leave more than half a length of material unsupported.



## Warnings

24. Support entire length of work. Some material will bend under its own weight. Set the rollers at the same height along the length of the material to keep it flat and level.
25. Stabilize material support stand. Use material stand on a level surface and bolt it to the floor whenever possible.

**Familiarize yourself with the following safety notices used in this manual:**

**CAUTION** This means that if precautions are not heeded, it may result in minor injury and/or possible machine damage.

**WARNING** This means that if precautions are not heeded, it may result in serious or even fatal injury.

**- - SAVE THESE INSTRUCTIONS - -**

## General Specifications

The JET Material Support Stands, Models SSH and SSVH, are designed to handle heavy loads of flat or round stock. Model SSH features a horizontal roller head that is used to support flat or rectangular shaped stock. Model SSVH features a V-shaped roller head that is used to support round stock.

The height of the roller head is adjustable to accommodate the height of the machine worktable. The roller head height is adjusted by loosening the clamping handle on the column, and moving the roller head up or down to the desired height.

The horizontal stand has a 2 x 14-inch ball bearing roller head. The V-roller stand has two 2 x 5-inch ball bearing rollers. The stand base and roller support are heavy duty castings.

Separate horizontal and V-roller heads are available for the support stand. Model SSHHO is the horizontal roller head; Model SSVHO is the V- roller head.

## Specifications

Stock Number.....	414121.....	414122
Model Number.....	SSH.....	SSVH
Roller Type.....	Horizontal .....	V-Shaped
Weight Capacity .....	2000 Pounds.....	2000 Pounds
Round Stock Capacity:		
Minimum Diameter.....	<i>Not Applicable</i> .....	1 Inch
Maximum Diameter.....	<i>Not Applicable</i> .....	12 Inches
Height Range .....	23 to 38.5 Inches.....	23 to 38.5 Inches
Length of Horizontal Roller .....	14 Inches.....	<i>Not Applicable</i>
Floor Area Required .....	16.5 x 16.5 Inches.....	16.5 x 16.5 Inches
Weight:		
Assembled Stand .....	44 Pounds.....	43 Pounds
Roller Head Only .....	12.5 Pounds.....	12 Pounds

The above specifications were current at the time this manual was published, but because of our policy of continuous improvement, Walter Meier (Manufacturing) Inc., reserves the right to change specifications at any time and without prior notice, without incurring obligations.

**⚠WARNING** Read and understand the entire contents of this manual before attempting assembly or operation! Failure to comply may cause serious injury!

# Introduction

This manual includes operating and maintenance instructions for the JET Model SSH and SSVH Material Support Stands. The manual also covers JET Model SSHHO and SSVHO Roller Heads used on the material support stands.

This manual also contains parts listings and illustrations of replaceable parts (refer to the **Replacement Parts** section).

## Set-up and Use

### Unpacking

1. Check for shipping damage. If any damage has occurred a claim must be filed immediately with the carrier to assure prompt response.
2. Check for completeness. Make sure all parts have been provided before attempting assembly. (Refer to the Replacement Parts section for parts breakdown.)

### Assembly

**CAUTION** Do not attempt assembly if parts are missing. Use instructions in this manual to order replacement parts.

1. Refer to exploded views in the Replacement Parts section for parts breakdown of the support stand. The reference numbers in the procedures correspond with the reference numbers in the exploded views.
2. Install retaining ring (9) on inner column (10).
3. Install nuts (6) finger tight on bolts (5); install as close to the head as possible. The nuts will be used as jam nuts after the screws are installed.
4. Install the outer column (2) in base (1). Insert the outer column (2) so it is seated against the shoulder in base (1). Install two bolts (4) and tighten nuts (3) against base (1) to secure.
5. Install inner column (10) into the outer column (2).
6. Clean surfaces of the inner column clamp (7) using a non-lubricating solvent. The surface of the inner column clamp (7) must be clean for proper clamping.
7. Install column clamp (7) onto the outside of the outer column (2) through inner column (10). Install two bolts (5) and tighten nuts (6)

against outer column (2) to secure. Install locking handle (8) in column clamp (7). Secure inner column (10) by tightening the locking handle (8).

8. Position the V-roller head (17) or horizontal roller head on inner column (10) so it is seated against the shoulder in roller head casting (11). Secure roller head (17) with two bolts (5). Tighten nuts (6) against head casting (11) to secure.
9. To interchange the roller heads, loosen bolts (5) and remove the roller head (17). Install the roller head (17) and tighten bolts (5) and nuts (6).

### Using the Material Support Stand

**WARNING** Although the operation of the material support stand is simple, the operator must perform the steps carefully. The material support stand can handle heavy loads, but if not used correctly, severe injury could result.

**Note:** The roller support stand must be used on a level surface and bolted to the floor whenever possible.

### Adjusting Roller Head Height

1. Adjust the height of the roller head by raising or lowering the inner column.
2. Lock the position of the roller head by tightening the locking handle.
3. The amount of clamping force between the column clamp and the inner column determines the amount weight the stand can support.
4. Keep the inner column clean. Accumulated oil, grease, splashed coolants, or machining debris caught between the inner column and column clamp will reduce the amount of clamping force.

### Moving Material on the Rollers

1. Adjust the roller head height so that the top of the roller is at the same height as the saw table.
2. The rollers are equipped with ball bearings to provide easy roller action.
3. When using multiple stands, make sure the stands are aligned so the material is centered over the stand. The material should glide smoothly over the rollers. Move the material slowly over the rollers; heavier material will be difficult to stop if it is moved too quickly.

4. Keep hands and fingers away from the rollers to avoid pinching hands or fingers between material and the rollers.

## **Maintenance**

### **Maintenance of the Rollers**

1. The roller head ball bearings (13) are sealed and require no lubrication.
2. Check bearings (13) for wear or binding. Replace worn or binding bearings.
3. Check roller shaft (15) and roller(s) for damage. Replace if damaged.

### **Maintenance of the Inner Column**

1. Check cleanliness of inner column. Keep the inner column clean and dry.
2. Check inner column for damage. Replace if damaged.

## **Replacement Parts**

Replacement parts are listed on the following pages. To order parts or reach our service department, call 1-800-274-6848, Monday through Friday (see our website for business hours, [www.waltermeier.com](http://www.waltermeier.com)). Having the Model Number and Serial Number of your machine available when you call will allow us to serve you quickly and accurately.



## Parts List: V-Roller Material Support Stand (Stock # 414122)

Index No.	Part No.	Description	Size	Qty
1	150-3020A-01	Base		1
2	150-3020A-02	Outer Column		1
3	TS-1540071	Hex Nut	M10	2
4	TS-1505041	Socket Head Cap Screw	M10x30	2
5	TS-1504051	Socket Head Cap Screw	M8x25	4
6	TS-1540061	Hex Nut	M8	4
7	150-3020A-07	Column Clamp		1
8	150-3020A-08	Handle		1
9	150-3020A-09	Retaining Ring	56 mm	1
10	150-3020A-10	Inner Column		1
11	150-3025A-11	V-Roller Housing		1
12	150-3020A-12	Spacer	16 mm	2
13	BB-6302Z	Ball Bearing	6302Z	4
14	150-3025A-14	Roller		2
15	150-3025A-15	Shaft		2
16	150-3025A-16	Roller Assembly (index #13,14,15)		2
17	150-3025A-17	Complete V-Roller Head Assembly		1
18	150-3025A-18	ID Label		1

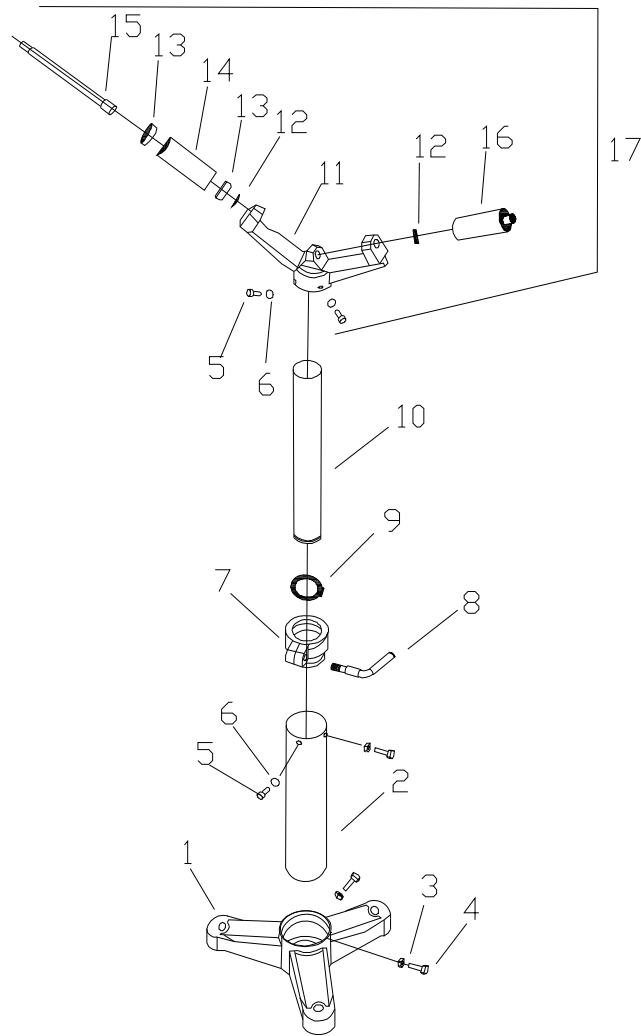

## Parts List: Horizontal Roller Material Support Stand (Stock # 414121)

Index No.	Part No.	Description	Size	Qty
1.....	150-3020A-01	Base.....		1
2.....	150-3020A-02	Outer Column.....		1
3.....	TS-1540071	Hex Nut.....	M10.....	2
4.....	TS-1505041	Socket Head Cap Screw.....	M10x30.....	2
5.....	TS-1504051	Socket Head Cap Screw.....	M8x25.....	4
6.....	TS-1540061	Hex Nut.....	M8.....	4
7.....	150-3020A-07	Column Clamp.....		1
8.....	150-3020A-08	Handle.....		1
9.....	150-3020A-09	Retaining Ring.....	56 mm.....	1
10.....	150-3020A-10	Inner Column.....		1
11.....	150-3020A-11	H-Roller Housing.....		1
12.....	150-3020A-12	Spacer.....	16 mm.....	2
13.....	BB-6302Z	Ball Bearing.....	6302Z.....	2
14.....	150-3020A-14	Roller.....		1
15.....	150-3020A-15	Shaft.....		1
16.....	150-3020A-16	Roller Assembly (index #13,14,15).....		1
17.....	150-3020A-17	Complete Horizontal Roller Head Assembly.....		1
18.....	150-3020A-18	ID Label.....		1

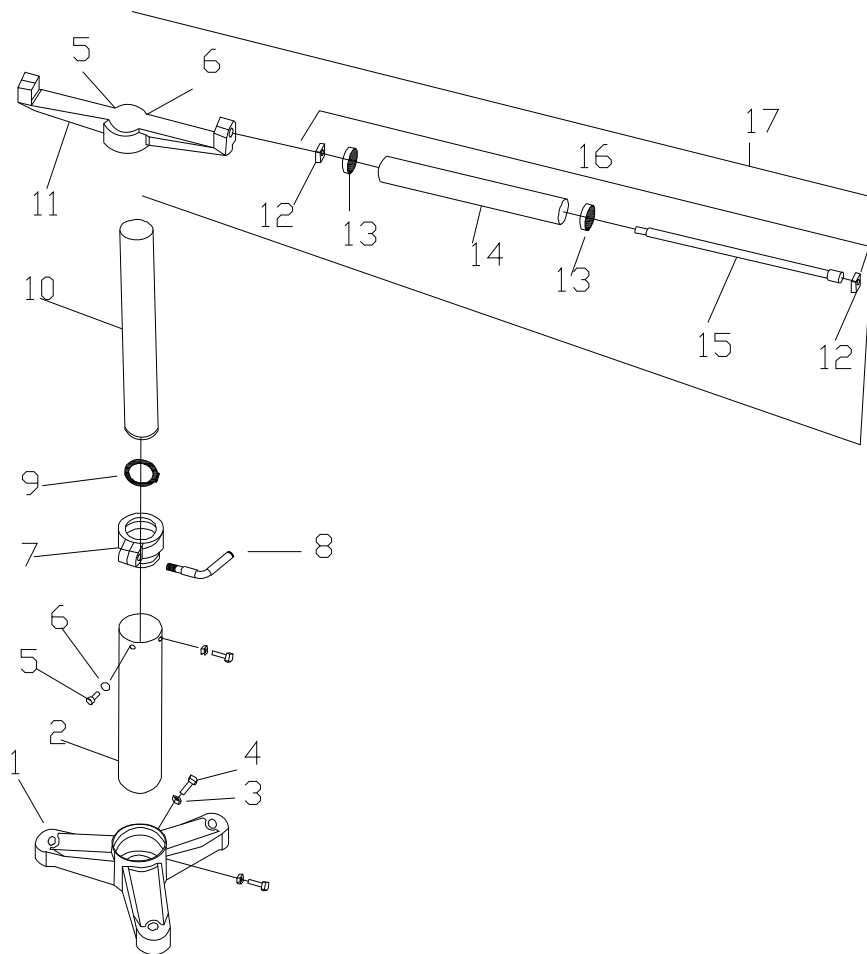





**WALTER MEIER (Manufacturing) Inc.**

427 New Sanford Road  
LaVergne, Tennessee 37086  
Phone: 800-274-6848  
[www.waltermeier.com](http://www.waltermeier.com)