

---

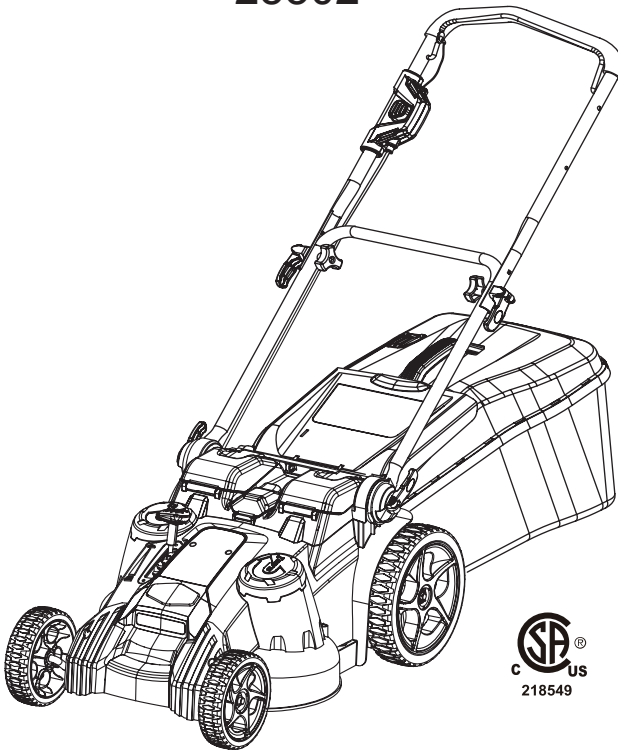

**greenworks™**

# 40 V Lithium-Ion Dual Blade Mower 25302



Owner's Manual

**TOLL-FREE HELPLINE: 1-888-90WORKS** (888.909.6757)

[www.GreenWorksTools.com](http://www.GreenWorksTools.com)

---

 Read all safety rules and instructions carefully before operating this tool.

# CONTENTS

---

Contents .....	2
Product specifications.....	2
Safety information.....	3-7
Symbols.....	8-9
Know your lawn mower .....	10
Assembly .....	11-17
Operation.....	18-22
Battery charger.....	23-24
Maintenance .....	25-28
Service .....	29
Environmentally safe battery disposal .....	30
Troubleshooting .....	31
Warranty .....	32
Exploded View .....	33
Parts List.....	34-36

## PRODUCT SPECIFICATIONS

---

### 40 V LITHIUM-ION DUAL BLADE MOWER

Battery type .....	40V Lithium-ion
Charger time.....	1 hour, for 40V 73Wh battery 2 hours, for 40V 146Wh battery
No-load speed .....	5000 RPM
Height adjustments.....	1 3/8- 3 3/8" (3.5 - 8.5 cm)
Functions .....	2-in-1: Mulch or rear bag
Unit weight (without battery) .....	42.5 lbs (19.3 kg)



# SAFETY INFORMATION

## GENERAL SAFETY RULES

### READ ALL INSTRUCTIONS CAREFULLY

#### **⚠ WARNING**

This symbol indicates important safety instructions. If these instructions are not followed, it could endanger the personal safety and/or property of the operator and others. Read and understand all instructions in this manual before attempting to operate the mower. Failure to comply with these instructions may result in personal injury.

#### **⚠ DANGER**

This mower was built to be operated according to the rules for safe operation that are contained in this manual. As with any type of power equipment, carelessness or error on the part of the operator can result in serious injury. This mower is capable of amputating body parts and throwing objects. Failure to observe the following safety rules could result in serious injury or death.

#### **⚠ WARNING**

Basic safety precautions should always be followed when using electric lawn mowers, in order to reduce the risk of fire, electric shock, and personal injury.

#### **⚠ WARNING**

Use of this mower should be restricted to individuals who have read and understood and will follow the warnings and instructions that are printed in this manual and on the mower.



stop

**⚠ DANGER      ⚠ PELIGRO      ⚠ DANGER**

AVOID SERIOUS INJURY OR DEATH

- To reduce risk of injury, user must read and understand operator's manual.
- To reduce the risk of electric shock, do not expose to water, do not use in rain.
- Replace damaged parts immediately.
- Remove the key before servicing, opening or removing blade.
- Do not mow when children and others are around.

- Remove object that could be thrown by the blade.
- Go across slopes, not up and down.
- Keep safety devices (guards, shields, switches ETC.) in place and working.
- Look down and behind before and while moving backwards.
- Always wear proper eye and hearing protection.

EVITE LAS LESIONES GRAVES Y LA MUERTE

- Para reducir el riesgo de lesiones, el usuario debe leer y comprender el manual del operador.
- Para reducir el riesgo de descargas eléctricas evite que el producto entre en contacto con el agua, no lo use bajo la lluvia.
- Reemplace inmediatamente las piezas dañadas.
- Retire la llave antes de realizar cualquier tipo de mantenimiento o de abrir o quitar la hoja.
- No corte el césped cuando haya niños u otras personas alrededor.

- Quite los objetos que obstaculicen el funcionamiento de la cuchilla y que puedan salir despedidos.
- Si se encuentra en una pendiente, crítica, no la baje ni la suba.
- Mantenga los dispositivos de seguridad (cubiertas, protectores, interruptores, ETC.) en su lugar y en funcionamiento.
- Mire hacia abajo y hacia atrás antes y mientras se desplaza hacia atrás.
- Use protección para los ojos y los oídos siempre.

ÉVITEZ LES BLESSURES GRAVES OU LA MORT

- Afin de réduire le risque de blessures, l'utilisateur doit lire et comprendre le manuel d'instructions.
- Afin de réduire les risques de chocs électriques, l'appareil ne doit pas entrer en contact avec de l'eau ni être utilisé sous la pluie.
- Remplacez immédiatement toute pièce endommagée.
- Retirez la clé avant d'ouvrir l'appareil, de procéder à son entretien ou de retirer la lame.
- Ne tondez pas la pelouse lorsque des enfants ou d'autres personnes sont aux alentours.

- Enlevez tout objet qui pourrait être projeté par la lame.
- Dans une pente, passez la tondeuse perpendiculairement et non de haut en bas.
- Assurez-vous que les dispositifs de protection (protecteurs, écrans, interrupteurs, etc.) sont en place et fonctionnent.
- Regardez vers le sol et derrière vous avant et pendant que vous réglez.
- Assurez-vous de protéger vos yeux et votre ouïe adéquatement.

# SAFETY INFORMATION

---

- Carefully read all instructions on the mower and in the manual before attempting to assemble and operate the mower. Keep this manual in a safe place for future reference, and consult it regularly.
- Become familiar with all controls and their proper operation. Know how to stop the mower and how to disengage the power in an emergency.
- In order to avoid contact with the blade or injury caused by a thrown object, stay in the operating zone behind the handles, and keep children and bystanders at least 50' (15 m) away from the mower while it is in operation. Stop the motor immediately if someone enters the mowing area.
- Thoroughly inspect the area where the mower is to be used. Remove all stones, sticks, wire, bones, toys, and other objects that could be tripped over or thrown by the blade. Thrown objects can cause serious personal injury.
- Plan your mowing pattern in such a way as to avoid discharging material toward roads, sidewalks, bystanders, etc. Do not discharge material against a wall or obstruction. Doing so may cause the discharged material to ricochet back toward the operator.
- Always wear proper eye protection that complies with ANSI Z87.1 in order to protect your eyes while operating or performing any adjustment or repair. Thrown objects that ricochet can cause serious eye injury.
- Always wear a face mask or a dust mask when operating the mower in a dusty environment.
- Dress properly. Do not wear loose clothing or jewelry that can get caught in moving parts. The wearing of protective gloves and safety footwear is recommended.
- Ground Fault Circuit Interrupter (GFCI) protection should be provided on the circuit(s) or outlet(s) that will be used to charge the lawn mower battery. Outlets with built-in GFCI protection are available, and may be used as an added safety measure.
- Many injuries occur as a result of the mower being pulled over the operator's foot during a fall caused by slipping or tripping. Do not operate this mower in bare feet, or while wearing sandals or lightweight (e.g., canvas) shoes. Do not hold on to the mower if you are falling. Release the handle immediately.
- Never pull the mower back toward you while you are walking. If you must back the mower away from a wall or an obstruction, first look down and behind in order to avoid tripping, and then follow these steps:
  - Step back from the mower in order to fully extend your arms.
  - Be sure that you are well balanced.
  - Pull the mower back slowly.
- Do not use the mower for any job except that for which it is intended. Do not force the mower.
- Do not operate the mower while under the influence of alcohol or drugs.
- Stay Alert: Do not operate the mower when you are tired. Pay attention to what you are doing. Use common sense.
- Do not put hands or feet near rotating parts or under the cutting deck. Contact with the blade can amputate hands and feet.
- Do not attempt to adjust the wheels or the cutting height while the motor is running.
- Avoid dangerous environments. Do not operate the mower in the rain or in wet or damp grass.
- Mow only in daylight or in good artificial light. Do not rush a mowing job.

# SAFETY INFORMATION

---

- Stop the blade when crossing gravel driveways, walkways, or roads.
- If the mower starts to vibrate excessively, stop the motor and check for the cause immediately. Vibration is generally a warning of trouble.
- Stop the motor and wait until the blade comes to a complete stop before removing the grass catcher or unclogging the chute. The cutting blade will continue to rotate for a few seconds after the motor is shut off. Do not place any part of your body in the blade area until you are sure that the blade has stopped rotating.
- Never operate mower without a proper trail shield, discharge cover, grass catcher, switch control, or other safety device in place and in working order. Do not operate the mower with damaged safety devices. Doing so can result in injury.
- Don't force lawn mower. It will do the job better and safer at the rate for which it was designed.
- Store idle lawn mower indoors. When not in use, lawn mower should be stored in an indoor dry and look-up place, out of reach of children.
- Maintain lawn mower. Keep cutting edgers sharp and clean for best and safety performance.
- If lawn mower strikes a foreign objects follow these steps:
  - Stop lawn mower, release the switch.
  - Remove the key and battery.
  - Inspect for damage.
  - Repair any damage before restarting and operating the lawn mower.
- Do not charge lawn mower in rain or in wet location.
- Remove or disconnect battery before servicing, cleaning or removing material from lawn mower.

## CHILD SAFETY

Tragic accidents can occur if the operator is not aware of the presence of children.

- Keep children out of the mowing area and under the watchful care of a responsible adult.
- Do not allow children under the age of 14 to operate this mower. Children who are 14 years of age and older must read and understand the operating instructions and safety rules in this manual, and must be trained and supervised by a parent.
- Stay alert, and turn the mower off if a child or any other person enters the mowing area.
- Look behind and down for small children before and while moving backwards.
- Use extreme care when approaching blind corners, doorways, shrubs, trees, or other objects that may obscure your view of a child who may run into the path of the mower.

## BATTERY & CHARGER

---

### CAUTION

USE ONLY GREENWORKS APPROVED REPLACEMENT BATTERIES, OTHER BATTERIES MAY CAUSE INJURY OR DAMAGE TO THE MOWER. Use with GREENWORKS 40V battery.

---

## BATTERY SAFETY RULES

- Battery tools do not have to be plugged into an electrical outlet; therefore, they are always in
-

# SAFETY INFORMATION

---

operating condition. Be aware of possible hazards when not using your battery tool or when changing accessories. Following this rule will reduce the risk of electric shock, fire, or serious personal injury.

- Do not place battery tools or their batteries near fire or heat. This will reduce the risk of explosion and possibly injury.
- Do not crush, drop or damage battery pack. Do not use a battery pack or charger that has been dropped or received a sharp blow. A damaged battery is subject to explosion. Properly dispose of a dropped or damaged battery immediately.
- Batteries can explode in the presence of a source of ignition, such as a pilot light. To reduce the risk of serious personal injury, never use any cordless product in the presence of open flame. An exploded battery can propel debris and chemicals. If exposed, flush with water immediately. Do not charge battery tool in a damp or wet location. Following this rule will reduce the risk of electric shock.
- For best results, your battery tool should be charged in a location where the temperature is more than 45°F but less than 104°F. To reduce the risk of serious personal injury, do not store outside or in vehicles.
- Under extreme usage or temperature conditions, battery leakage may occur. If liquid comes in contact with your skin, wash immediately with soap and water. If liquid gets into your eyes, flush them with clean water for at least 10 minutes, then seek immediate medical attention. Following this rule will reduce the risk of serious personal injury.
- When battery pack is not in use, keep it away from other metal objects like: paper clips, coins, keys, nails, screws, or other small metal objects that can make a connection from one terminal to another. Shorting the battery terminals together may cause sparks, burns, or a fire.
- Always remove battery pack from your tool when you are assembling parts, making adjustments, cleaning, or when not in use. Removing battery pack will prevent accidental starting that could cause serious personal injury.
- Always remove battery pack before storing the device. When battery becomes fully charged, unplug the charger from the power supply and remove the battery pack from the charger.
- Always wear eye protection with side shields marked to comply with ANSI Z87.1, along with hearing protection. Failure to do so could result in objects being thrown into your eyes and other possible serious injuries.
- Keep battery pack dry, clean, and free from oil and grease. Always use a clean cloth when cleaning. Never use brake fluids, gasoline, petroleum-based products, or any solvents to clean battery pack.
- When replacing batteries, all batteries should be replaced at the same time. Mixing fresh and discharged batteries could increase internal cell pressure and rupture the discharge battery(ies). (Applies to products employing more than one separately replaceable primary battery.)
- When inserting batteries into this product, the proper polarity or direction must be observed. Reverse insertion of batteries can result in leakage or explosion. (Applies to product employing more than one separately replaceable primary battery.)

## PROPER CARE FOR BATTERY

Off-season storage

To obtain the longest possible battery life, we suggest the following:

# SAFETY INFORMATION

---

- Remove the battery pack from the charger once it is fully charged and ready for use.

For battery pack storage longer than 30 days:

- Store the battery pack where the temperature is below 80°F and away from moisture.
- Store battery packs in a 30%-50% charged condition.
- Every two months of storage, charge the pack as normal.

## CHARGER SAFETY RULES

- Charge the mower battery in a dry area that is protected from the weather. Do not expose the mower or the charger to rain. Do not charge the battery in a wet location. Operate the battery charger in temperatures between 45° and 104°F. In order to reduce the risk of electric shock, use only the charger that is provided by the manufacturer to charge the battery.
- **DO NOT ABUSE THE CHARGE CORD.** Never carry the charger by the cord. Do not disconnect the charger from the outlet or from the mower by pulling the charger cord.
- Do not use a damaged charger. Replace the charger cords or the charger immediately.
- Keep the mower and the charger away from water, heat sources (radiators, heaters, stoves, etc.), flames, and chemicals.
- Make sure the battery pack is secured in the charger before beginning operation.
- The battery pack will become slightly warm to the touch while charging. This is normal and does not indicate a problem.
- Do not place the charger and battery pack in an area of extreme heat or cold. They will work best at normal room temperature.
- When batteries become fully charged, unplug the charger from the power supply and remove the battery pack.

---

## **WARNING**

When transporting or servicing unit, always remove the key and battery.

---

---

## **WARNING (PROPOSITION 65)**

Some dust created by power sanding, sawing, grinding, drilling and other construction activities contains chemicals known to the state of California to cause cancer, birth defects or other reproductive harm. Some examples of these chemicals are:

- Lead from lead-based paints,
- Crystalline silica from bricks and cement and other masonry products, and
- Arsenic and chromium from chemically-treated lumber.

Your risk from these exposures varies, depending on how often you do this type of work. To reduce your exposure to these chemical: work in a well ventilated area, and work with approved safety equipment, such as those dust masks that are specially designed to filter out microscopic particles.













---

**SAVE THESE INSTRUCTIONS**

---

# SYMBOLS

Some of the following symbols may be used on this product. Please study them and learn their meaning. Proper interpretation of these symbols will allow you to operate the product better and safer.



SYMBOL	DESIGNATION/EXPLANATION
V	Volts
A	Amperes
Hz	Hertz
W	Watts
Hrs	Hours
	Precautions that involve your safety.
	To reduce the risk of injury, user must read and understand user's manual before using this product.
	Wear eye and head protection when operating this equipment.
	Do not expose machine to rain or wet conditions.
	Pay attention that bystanders are not injured through foreign objects thrown from the mower.
	Keep all bystanders (especially children and pets) at least 15 m away from the work area.
	Keep hands and feet away from blade and cutting area.
	Switch off and remove isolator key before adjusting, cleaning and before leaving the product unattended for any period.
	Do not operate on inclines greater than 15°. Mow across the face of slopes, never up and down.
	Beware of electric shock hazard.
	Wait for all components of machine to have completely stopped before touching them.
	The charger is intended for indoor use only.



# SYMBOLS

---

The following signal words and meanings are intended to explain the levels of risk associated with this product.

SYMBOL	SIGNAL	MEANING
	<b>DANGER</b>	Indicates an imminently hazardous situation, which, if not avoided, will result in death or serious injury.
	<b>WARNING</b>	Indicates a potentially hazardous situation, which, if not avoided, could result in death or serious injury.
	<b>CAUTION</b>	Indicates a potentially hazardous situation, which, if not avoided, may result in minor or moderate injury.
	<b>CAUTION</b>	(Without Safety Alert Symbol) Indicates a situation that may result in property damage.

## ENVIRONMENTAL PROTECTION



Waste electrical products should not be disposed of with household waste. Please recycle where facilities exist. Check with your local authority or retailer for recycling advice.

The battery contains material which is hazardous to you and the environment. It must be removed and disposed of separately at a facility that accepts lithium-ion batteries.

## SERVICE

Servicing requires extreme care and knowledge and should be performed only by a qualified service technician. For service we suggest you return the product to your nearest **AUTHORIZED SERVICE CENTER** for repair. When servicing, use only identical replacement parts.

---

## WARNING

To avoid serious personal injury, do not attempt to use this product until you have read this Owner's Manual thoroughly and understand it completely. If you do not understand the warnings and instructions in this Owner's Manual, do not use this product. Call the Toll-free Helpline (1-888-909-6757) for assistance.

---

## WARNING



The operation of any power tool can result in foreign objects being thrown into your eyes, which can result in severe eye damage. Before beginning power tool operation, always wear safety goggles or safety glasses with side shields and, when needed, a full face shield. We recommend Wide Vision Safety Mask for use over eyeglasses or standard safety glasses with side shields. Always use eye protection which is marked to comply with ANSI Z87.1.

---

## SAVE THESE INSTRUCTIONS

---

# KNOW YOUR LAWN MOWER

Read this operator's manual and safety rules before operating your lawn mower. Compare the illustration in Figure 1 to your lawn mower in order to familiarize yourself with the location of various controls and adjustments. Save this manual for future reference.

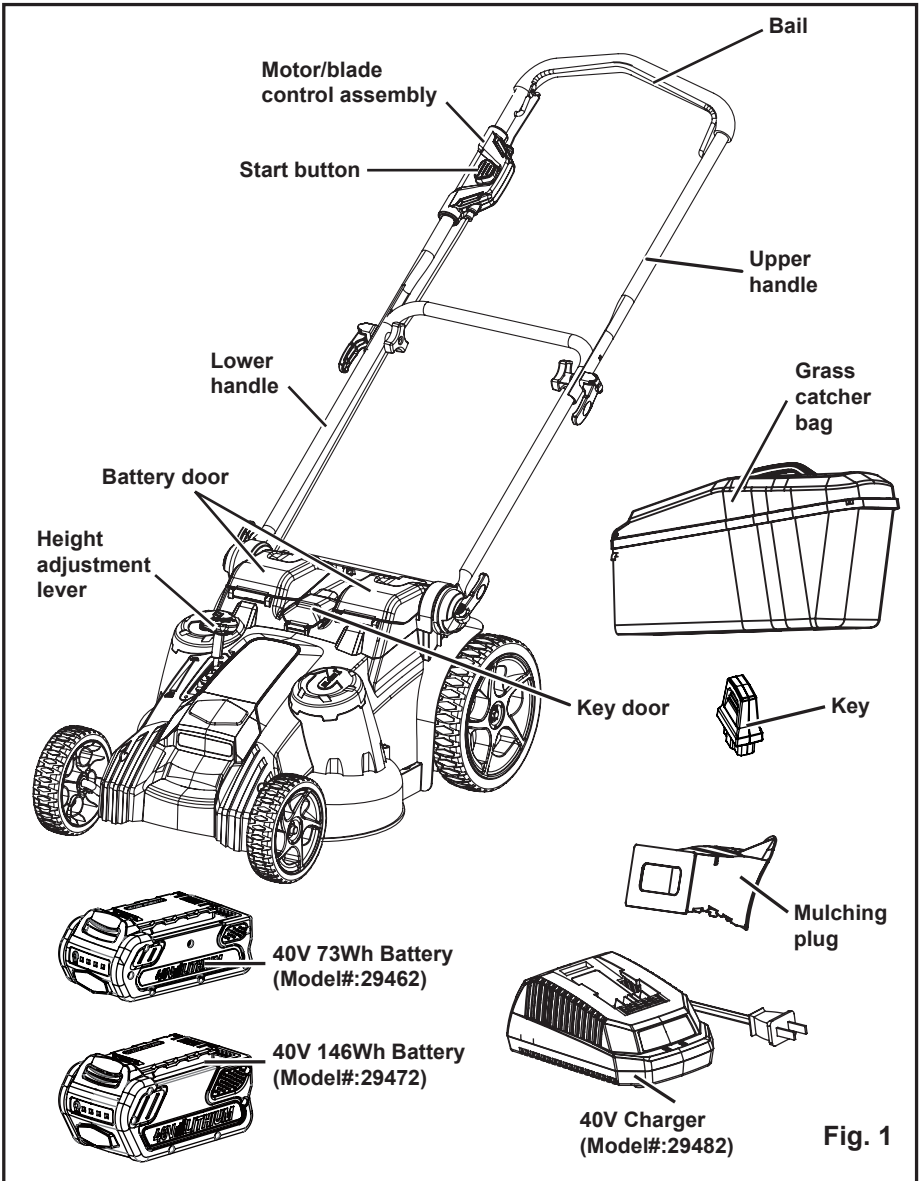

Fig. 1

# ASSEMBLY INSTRUCTIONS

---

## UNPACKING

- Carefully remove the product and any accessories from the box. Make sure that all items listed in the packing list are included.
- Inspect the product carefully to make sure no breakage or damage occurred during shipping.
- Do not discard the packing material until you have carefully inspected and satisfactorily operated the product.
- If any parts are damaged or missing, please call 1-888-909-6757 for assistance.

## PACKING LIST

- Lawn mower
- Key
- Mulching plug
- Grass catcher bag
- 40V 146Wh Battery (Model#:29472)
- 40V 73Wh Battery (Model#:29462)
- 40V Charger (Model#:29482)
- Owner's Manual

---

### **WARNING**

If any parts are damaged or missing do not operate this product until the parts are replaced. Using a product with damaged or missing parts could result in serious personal injury.

---

---

### **WARNING**

Do not attempt to modify this product or create accessories not recommended for use with this product. Any such alteration or modification is misuse and could result in a hazardous condition leading to possible serious personal injury.

---

---

### **WARNING**

Do not insert key until assembly is complete and you are ready to mow. Failure to comply could result in accidental starting and possible serious personal injury.

---

---

### **WARNING**

To prevent accidental starting that could cause serious personal injury, always remove the battery pack from the product when assembling parts.

---

---

### **WARNING**

Never operate the mower without the proper safety devices in place and working. Never operate the mower with damaged safety devices. Operation of this product with damaged or missing parts could result in serious personal injury.

---

# ASSEMBLY INSTRUCTIONS

## UNFOLDING AND ADJUSTING HANDLE ASSEMBLY (See Figure 2-3)

### To raise handle assembly:

- Open the lower handle locks.
- Pull up and back on the lower handle until it is aligned with the slot between the handle locks and the mower housing.

*NOTE: If the lower handle is difficult to move, turn the lower handle locks counterclockwise to free the handle.*

- To secure the lower handle in place, close the lower handle locks.

*NOTE: If the lower handle is loose or does not seat completely in the slot, turn the lower handle locks clockwise to secure the handle.*

- Open the upper handle locks.
- Pull up and back on the upper handle to raise it into operating position. Make sure that the lower handle is seated in the grooves at the bottom of the upper handle.
- To secure the upper handle in place, close the upper handle locks.

*NOTE: If the upper handle is loose or separated from the lower handle, tighten the knobs on the upper handle locks by turning them clockwise.*

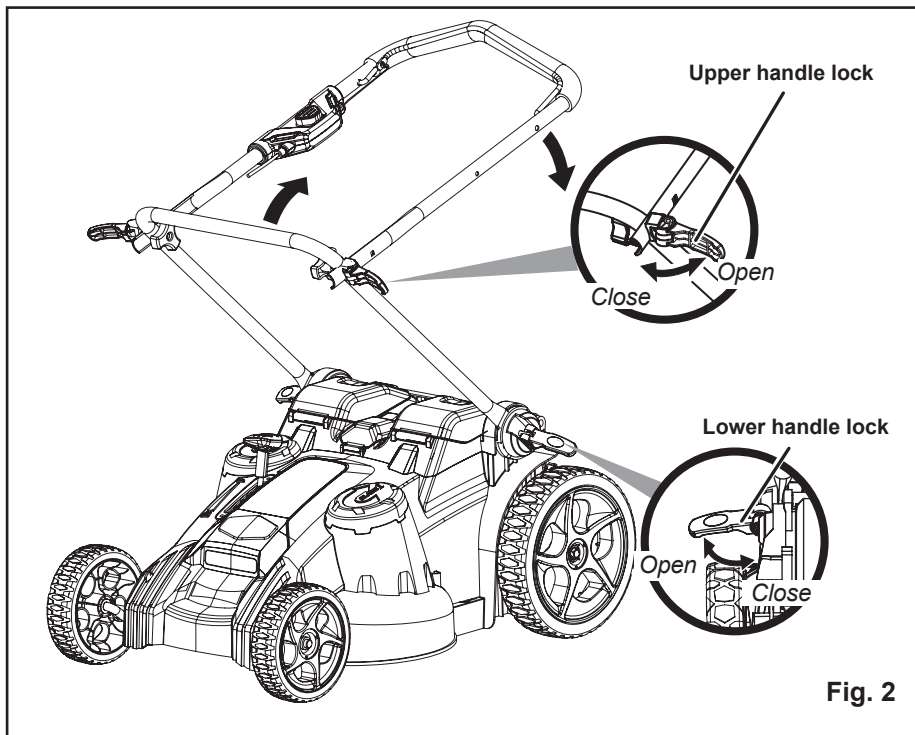

**Fig. 2**

# ASSEMBLY INSTRUCTIONS

---

## To lower the handle assembly:

- Open the upper handle locks.

*NOTE: If the handle lock is difficult to open, loosen the knobs on the upper handle locks by turning them counterclockwise.*

- Lower the upper handle.
- Open the lower handle lock.
- Push outward on each side of the lower handle until it is free from the slot. Then, fold the handle to the front of the unit. Avoid pinching or trapping any cables.

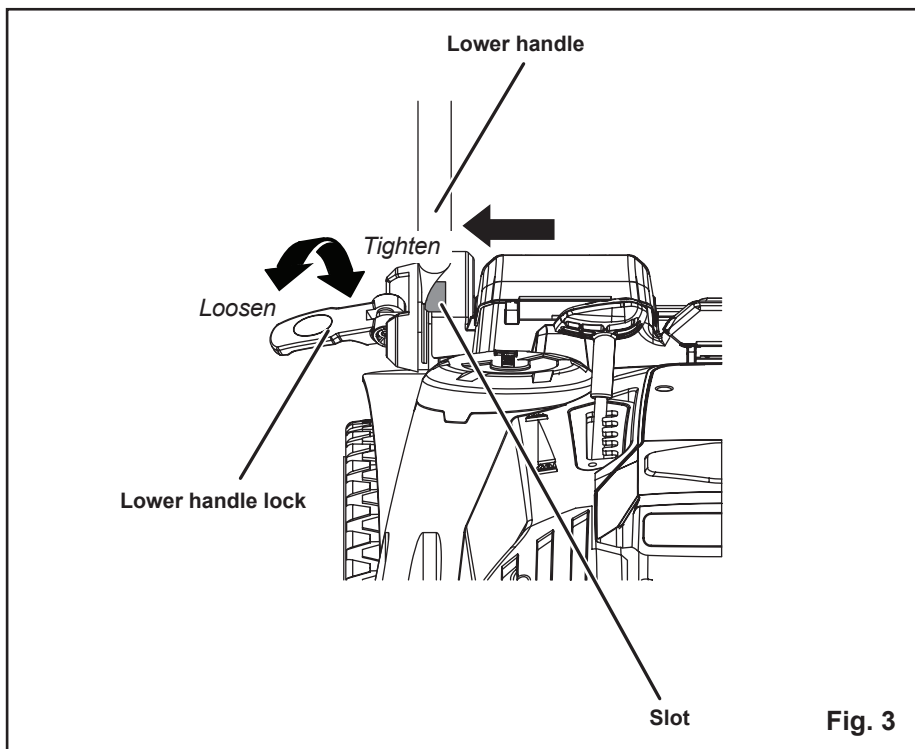

# ASSEMBLY INSTRUCTIONS

## INSTALLING THE MULCHING PLUG (FOR MULCHING OPERATION) (See Figure 4)

*NOTE: When using the mulching plug, do not install the grass catcher.*

- Remove key and battery pack.
- Lift and hold the rear discharge door.
- Grasp the mulching plug by its handle and insert it at a slight angle, as shown.
- Push the mulching plug securely into place.
- Lower the rear discharge door.
- Reinstall key and battery pack when you are ready to mow.

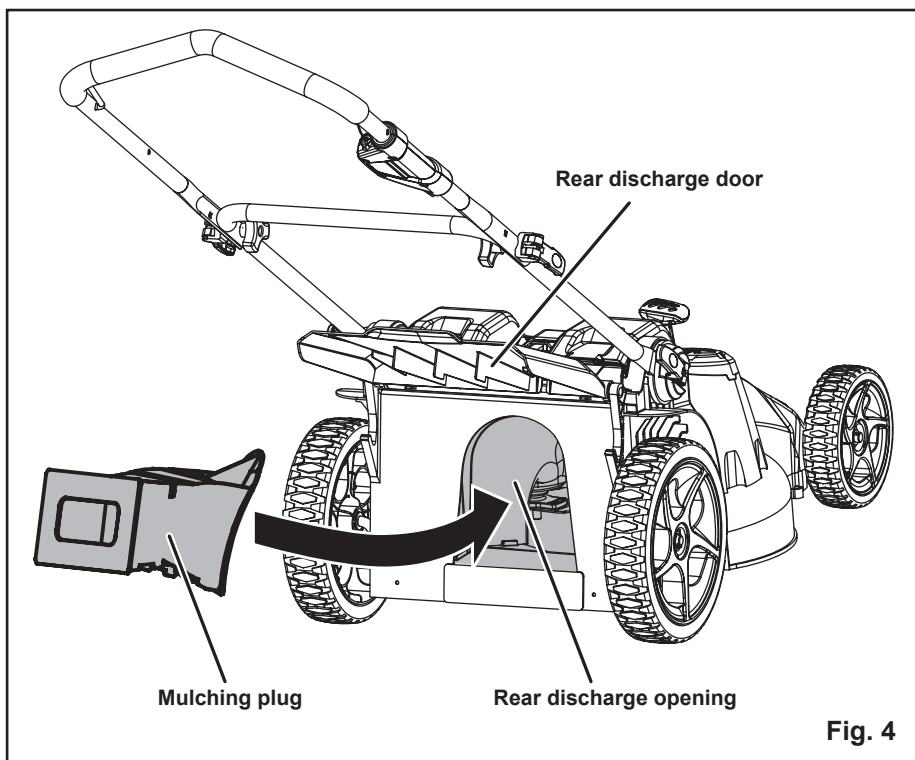

**Fig. 4**

# ASSEMBLY INSTRUCTIONS

## INSTALLING THE GRASS CATCHER (FOR REAR BAGGING OPERATION) (See Figure 5-6)

*NOTE: When using the grass catcher, do not install the mulching plug.*

- Remove key and battery pack.
- Lift the rear discharge door.
- Lift the grass catcher by its handle and place under the rear discharge door so that the hooks on the grass catcher are seated onto the slots on the mower housing.
- Release the rear discharge door.
- Reinstall key and battery pack when you are ready to mow.

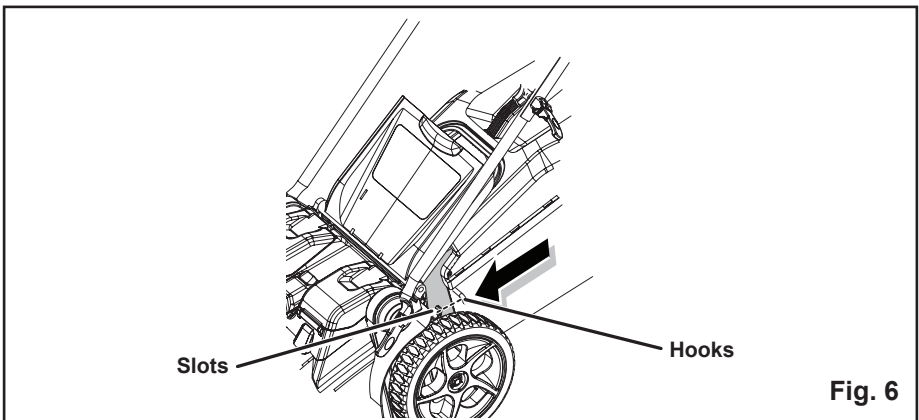
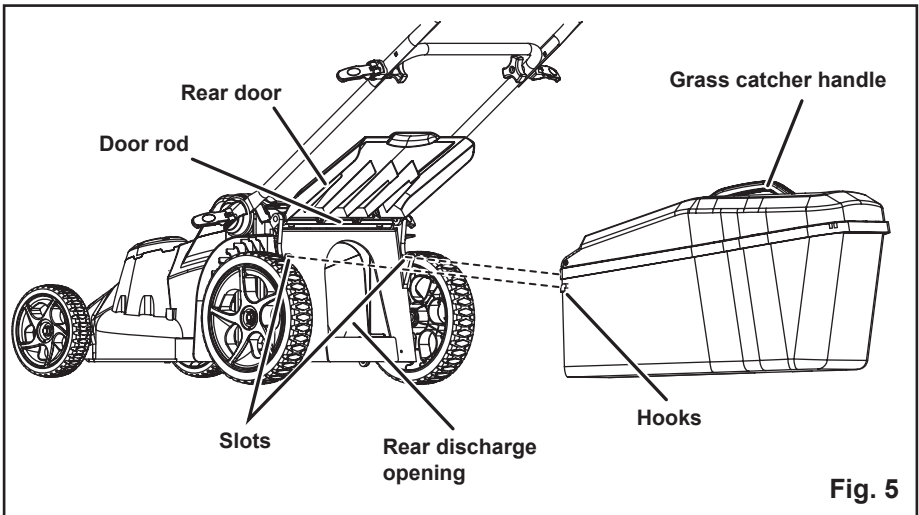

# ASSEMBLY INSTRUCTIONS

## TO INSTALL BATTERY PACK (See Figure 7)

### **⚠ WARNING**

Always remove battery pack and key from your tool when you are assembling parts, making adjustments, cleaning, or when not in use. Removing battery pack and key will prevent accidental starting that could cause serious personal injury.

- Raise the battery cover.
- Place the battery pack in the mower.
- Align raised ribs on battery pack with grooves in the mower's battery port.
- Push down into battery compartment until the battery clicks into place.
- Lower the battery cover.
- When installing the 73Wh Battery, follow the instructions above. There will be a gap between the battery and battery compartment. This is normal.

### **⚠ WARNING**

Make sure the latch on the top of the battery pack snaps in place and the battery pack is fully seated and secure in the mower's battery port before beginning operation. Failure to securely seat the battery pack could cause the battery pack to fall out, resulting in serious personal injury.

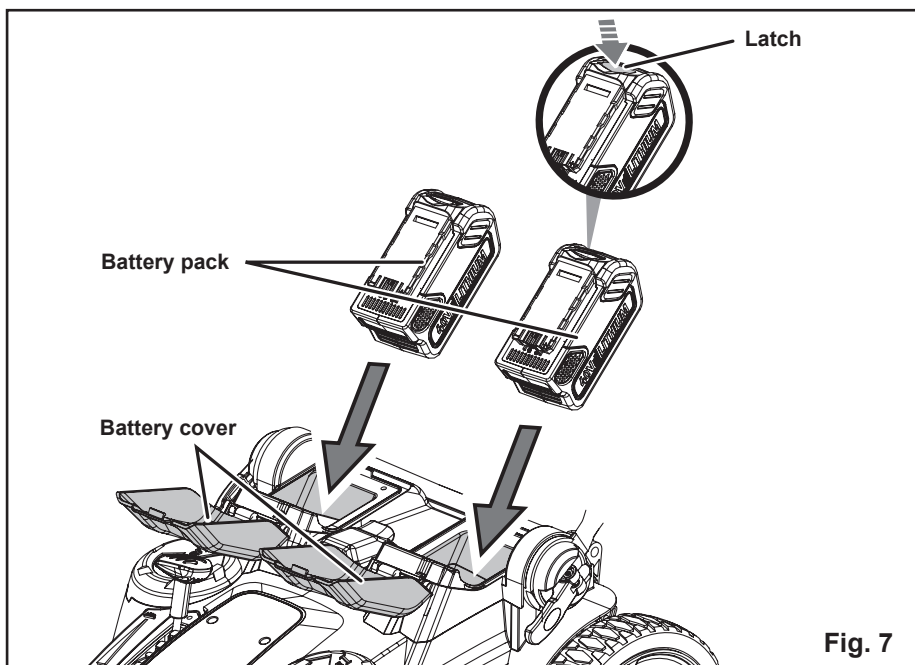



# ASSEMBLY INSTRUCTIONS

---

## TO REMOVE BATTERY PACK (See Figure 7)

- Raise the battery cover.
- Press and hold the battery latch button at the top of the battery pack.
- Remove battery pack from the mower.

---

## **⚠** WARNING

To avoid serious personal injury, always remove the battery pack and key when carrying or transporting the tool.

---

## TO INSTALL KEY (See Figure 8)

- Raise the key cover.
- Insert the key into the slot.
- Lower the key cover.

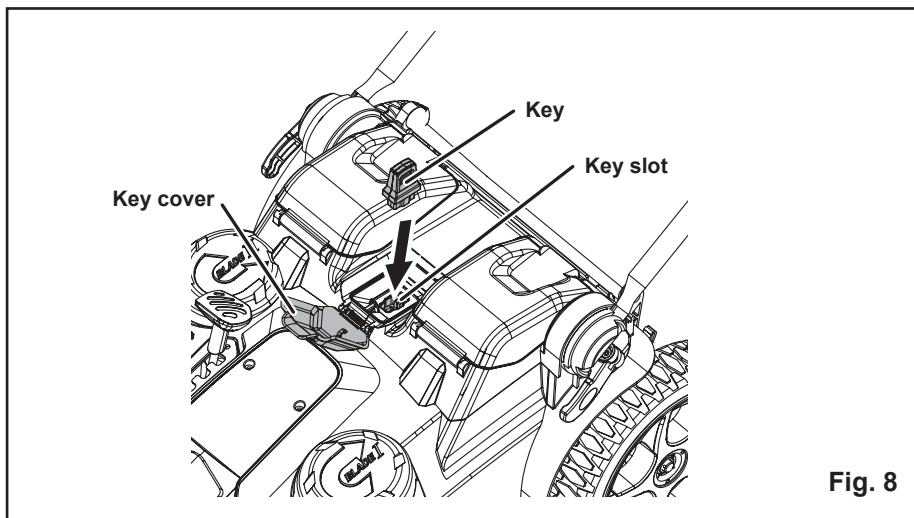

# OPERATING YOUR LAWN MOWER

---

## **STARTING/STOPPING THE MOWER** (See Figure 9)

- Raise the battery cover.
- Install battery pack.
- Lower the battery cover.
- Raise the key cover.
- Insert the key into the slot.
- Lower the key cover.
- Press and hold the start button. Pull the bail toward the handle and release the button to start the mower.
- To stop the mower, release the bail.

*NOTE: Power Save feature automatically adjusts the cutting speed of the blades to match the application to give the best possible cut while maximizing run time and battery life.*

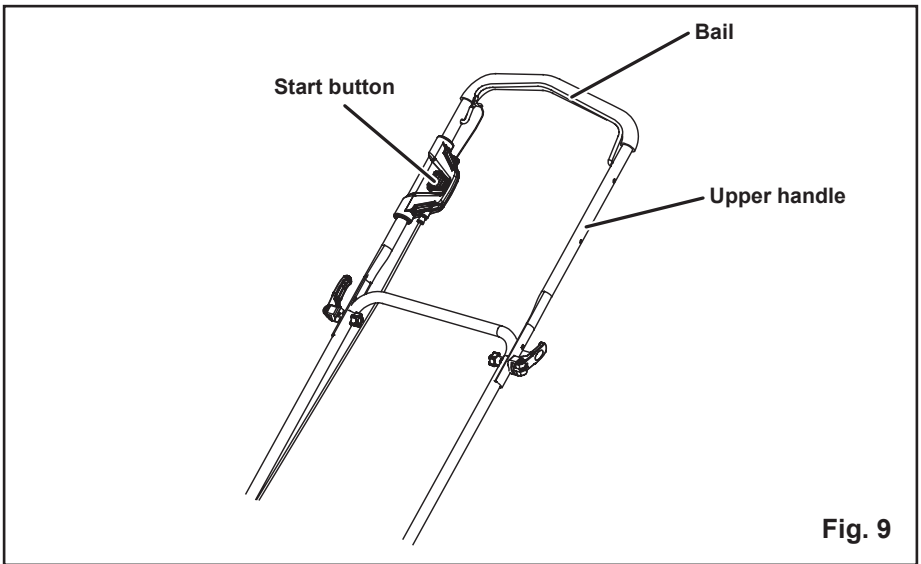

# OPERATING YOUR LAWN MOWER

## SETTING BLADE HEIGHT *(See Figure 10)*

When shipped, the wheels on the mower are set to a low-cutting position. Before using the mower for the first time, raise the cutting position to the height best suited for your lawn. The average lawn should be between 1-1/2 in. to 2 in. during cool months and between 2 in. and 3-1/4 in. during hot months.

### To adjust the blade height:

- Remove key and battery pack.
- To raise the blade height, grasp the height adjustment lever and move it toward the front of the mower.
- To lower the blade height, grasp the height adjustment lever and move it toward the back of the mower.
- Reinstall key and battery pack when you are ready to mow.

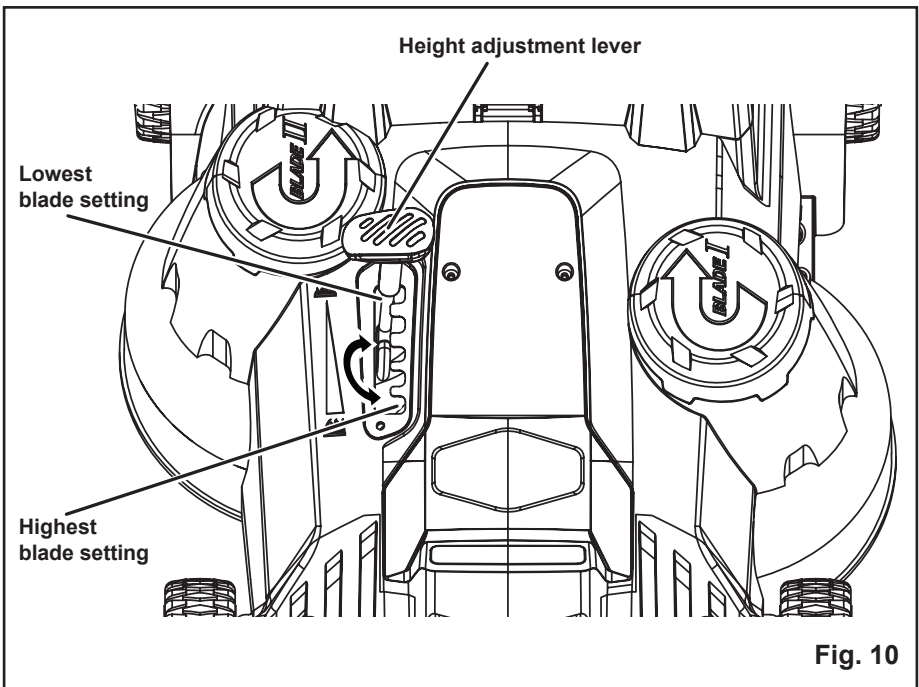

# OPERATING YOUR LAWN MOWER

## SLOPE GAUGE (See Figure 11)

### **⚠ WARNING**

Slopes are a major factor related to accidents involving slips and falls, which can result in severe injury. Operating the mower on a slope requires extra caution. If you feel uneasy on a slope, do not mow it. For your safety, use the slope gauge that is included as part of this manual to measure slopes before operating this unit on a sloped or hilly area.

- Mow across the face of a slope, and never up and down. Exercise extreme caution when changing direction on a slope.
- Watch for holes, ruts, rocks, hidden objects, or bumps that may cause a slip or a trip. Tall grass can hide obstacles.
- Always be sure of your footing. If you feel like you are losing your balance, release the blade/motor control handle immediately. The blade will stop rotating within 3 seconds.
- Do not mow near drop-offs, ditches, or embankments, because you could lose your footing or balance.
- Do not mow a slope that has an angle of greater than 15°, as determined using the slope gauge.
- Do not mow wet or damp grass. Unstable footing can cause slipping.

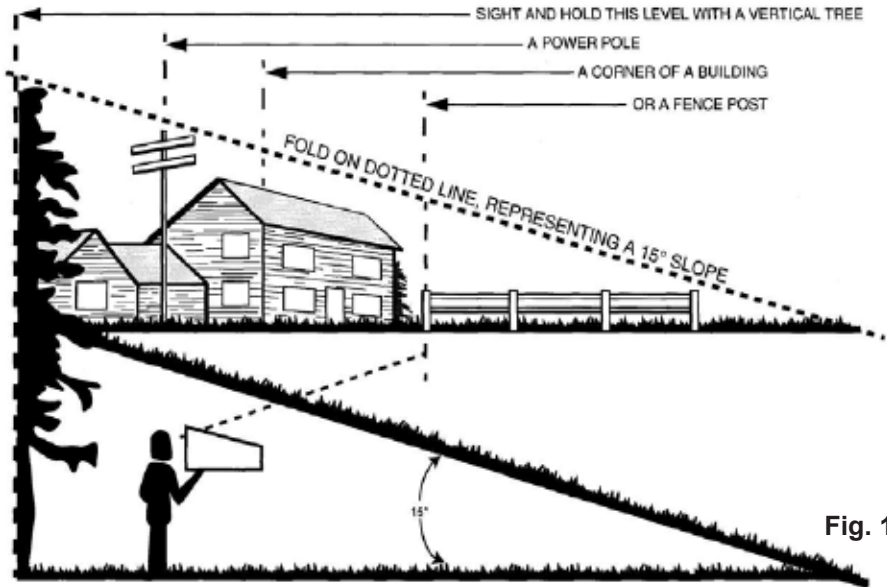

Fig. 11

### **⚠ WARNING**

Do not mow a slope that has an angle of greater than 15° (a rise of approximately 2 1/2' [.75 m] every 10' [3 m]). Mow across the face of a slope, and never up and down.

# OPERATING YOUR LAWN MOWER

---

## MOWING TIPS

*NOTE: A sharp blade will greatly enhance the performance of the mower, especially when cutting high grass. Be sure to check the blade and to sharpen it at least once per year, as described in the Maintenance section.*

- Verify that the lawn is free of stones, sticks, wires, and other objects that could damage the blades or the motor. These objects could be accidentally thrown by the mower in any direction, and could cause serious personal injury to the operator and to others. In order to prevent electric shock, do not operate the mower in damp or wet conditions.
- Do not mow in circles. Travel back and forth across the lawn.
- When cutting thick grass, reduce walking speed in order to allow for a more effective cut and a proper discharge of the clippings.
- For a healthy lawn, always cut off one-third or less of the total length of the grass. The average lawn should be approximately 1 1/2 to 2" (3.8 to 5 cm) long during cool months, and between 2" to 3 1/4" (5 cm to 8.3 cm) long during hot months. If there is growth, the lawn should be cut in the fall.

## MULCHING TIPS

*NOTE: INSPECT THE AREA WHERE THE MOWER IS TO BE USED, AND REMOVE ALL STONES, STICKS, WIRE, BONES, AND OTHER DEBRIS THAT MIGHT BE THROWN BY THE ROTATING BLADE.*

- Release the switch to turn the mower OFF when crossing any graveled area (stones can be thrown by the blade).
- Set mower to the highest cutting height when mowing on uneven ground or in tall weeds.
- For effective mulching, do not cut wet grass, because it tends to stick to the underside of the deck, preventing proper mulching of grass clippings. New or thick grass may require a narrower cut. The ground speed should be adjusted to the condition of the lawn. If mowing has been delayed and the grass has been allowed to grow longer than 4" (10 cm), mow the lawn twice in order to reduce the grass height to a maximum of 3 1/4" (8.3 cm).
- Walk at a steady pace. Overlap the cutting rows. Do not let the grass get too tall. If the grass gets too long, start at the highest cutting position and work down to the desired cutting height.

---

## WARNING

If you strike a foreign object, stop the motor and remove the battery. Thoroughly inspect the mower for any damage. Repair any damage before operating the mower. Excessive vibration of the mower during operation is an indication of damage. Thoroughly inspect the mower and repair any damage before operating the mower.

---

# OPERATING YOUR LAWN MOWER

---

## EMPTYING THE GRASS CATCHER BAG (See Figure 12-13)

- Stop the mower and allow blades to completely stop.
- Remove key and battery pack.
- Lift the rear discharge door.
- Lift the grass catcher by its handle to remove from mower.
- Empty grass clippings.
- Lift the rear discharge door and reinstall the grass catcher as described earlier in this manual.
- Reinstall key and battery pack when you are ready to mow.

*NOTE: When you start the mower, the full bag indicator of the grass catcher will lift up. Once the grass catcher is full, the full bag indicator will fall wholly. So the grass catcher bag need to be empty.*

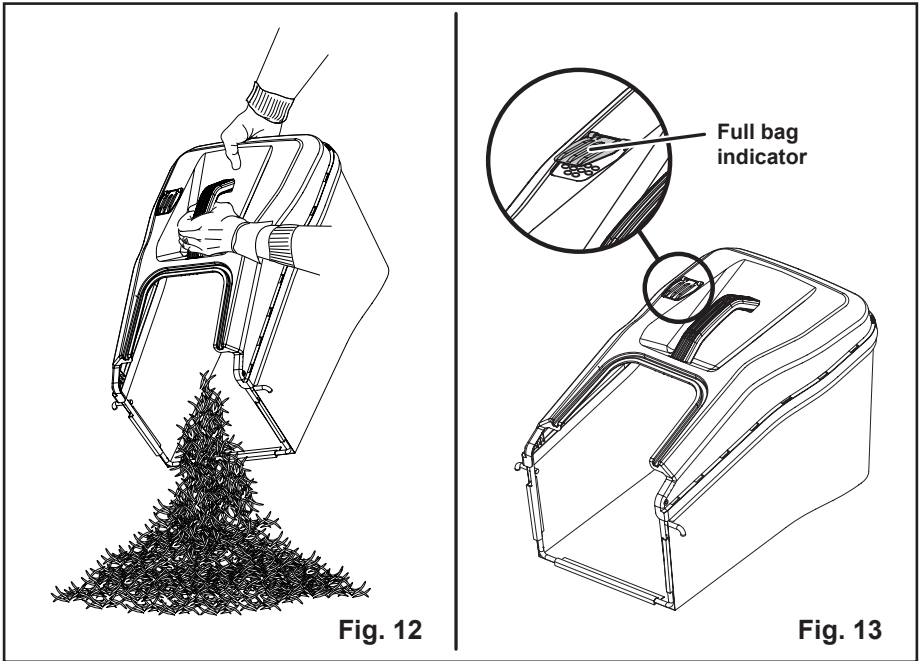

# BATTERY CHARGER

## CHARGING PROCEDURE (See Figure 14)

*NOTE: The battery is not shipped fully charged. It is recommended to fully charge before first use to ensure that maximum run time can be achieved. This lithium-ion battery will not develop a memory and may be charged at any time. A fully discharged battery pack will require approximately 60 minutes (73Wh) / 120 minutes (146Wh) to fully charge from a discharged state.*

- Plug the charger into an AC power outlet.
- Insert the battery pack (1) into the charger (2).

This is a diagnostic charger. The Charger LED Lights (3) will illuminate in specific order to communicate the current battery status. They are as follows:

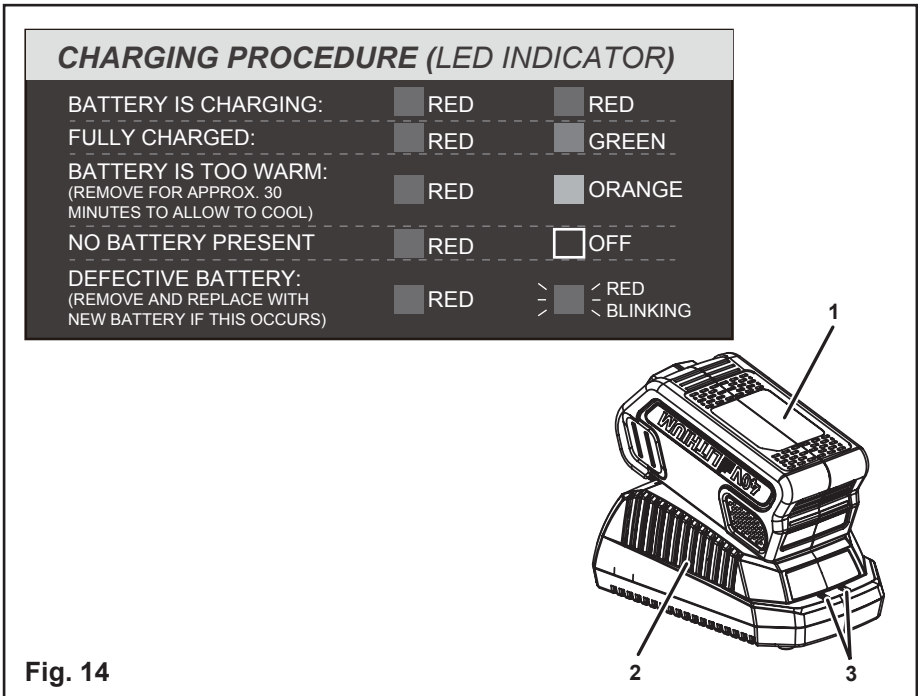

**Fig. 14**

## CHECKING THE CHARGE

If the battery pack does not charge properly:

- Check the current at the power outlet with another tool. Make sure that the outlet is not turned off.
- Check that the charger contacts have not been shorted by debris or foreign material.
- If the surrounding air temperature is not normal room temperature, move the charger and battery pack to a location where the temperature is between 45°F and 104°F.

# BATTERY CHARGER

---

## CHARGER MAINTENANCE

- Keep the charger clean and clear of debris. Do not allow foreign material into the recessed cavity or on the contacts. Wipe with a dry cloth. Do not use solvents, water, or place in wet conditions.
- Always unplug the charger when there is no battery pack in it.
- The battery pack may be stored in the charger. however, it is recommended to disconnect the charger from the power source. To ensure safety and reliability all repairs should be performed by a qualified service technician.
- Check that the charger contacts have not been shorted by debris or foreign material.

## CHARGER MOUNTING *(See Figure 15)*

- This charger can be installed hanging on a wall using two screws (not supplied)
- Locate the placement for the charger to be wall mounted.
- If fastening to wood studs use 2 wood screws.
- Drill two holes 2 3/8" (6 cm) on center ensuring they are level.
- If fastening to dry wall use wall anchors and screws to secure the charger to the wall.

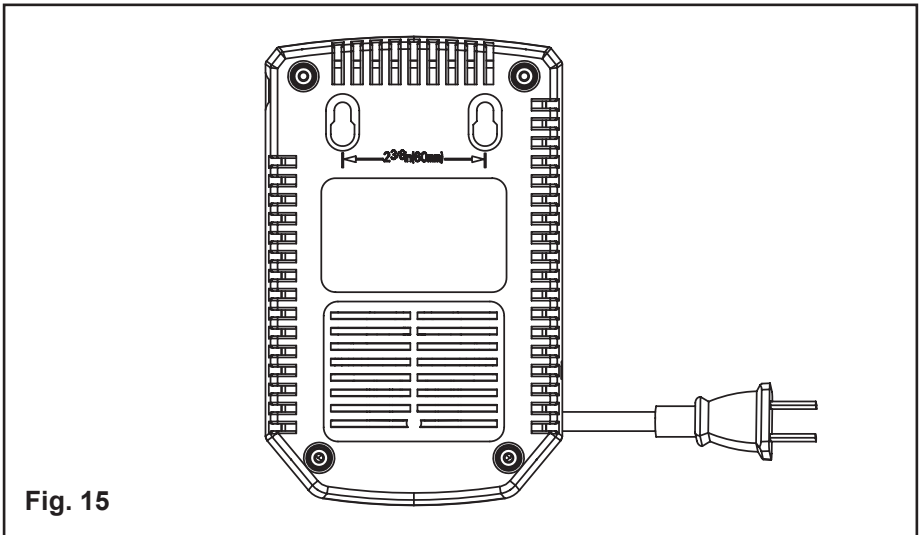

**Fig. 15**



# MAINTENANCE

## REPLACING THE CUTTING BLADE (See Figure 16-17)

### **⚠ WARNING**

Always protect your hands by wearing heavy gloves and/or wrapping the cutting edges with rags or other materials when performing any maintenance on the blades. ALWAYS remove the key and battery when servicing or transporting the mower.

Only use authorized replacement blades.

- Stop the motor and remove the key. Allow blade to come to a complete stop.
- Remove the battery pack.
- Turn the mower on its side.
- Wedge a block of wood between the blade and mower deck to prevent the blade from turning.
- For the **BLADE I**, loosen the blade nut by turning it counterclockwise (as viewed from bottom of mower) using a 15 mm wrench or socket (not provided). For the **BLADE II**, loosen the blade nut by turning it clockwise (as viewed from bottom of mower) using a 15 mm wrench or socket (not provided).
- Remove the blade nut, spacer, blade insulator, and blade.
- Make certain the motor assembly is pushed completely against the motor shaft.
- Place the new blade on the shaft against the motor assembly. Ensure blade is properly seated with shaft going through center blade hole and the two blade posts inserted into their respective holes on the blade. Make sure it is installed with the curved ends pointing up toward the mower deck and not down toward the ground. When seated properly, the blade should be flat against the motor assembly.

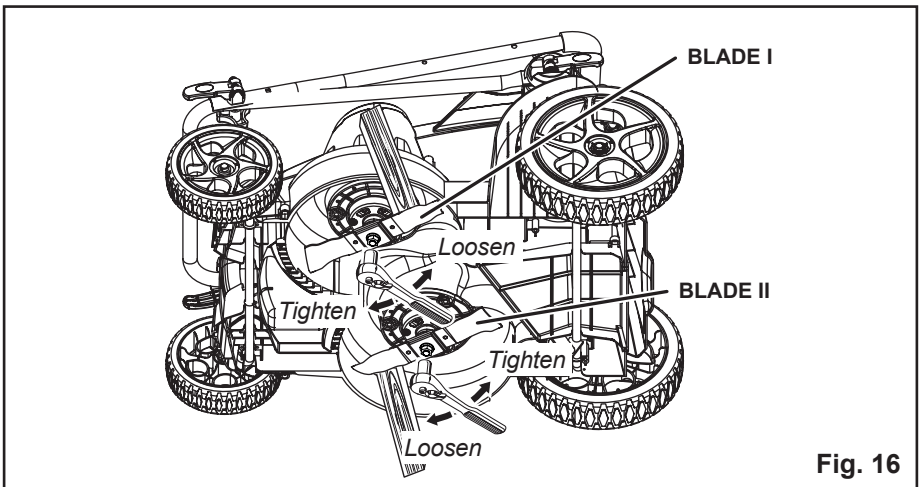
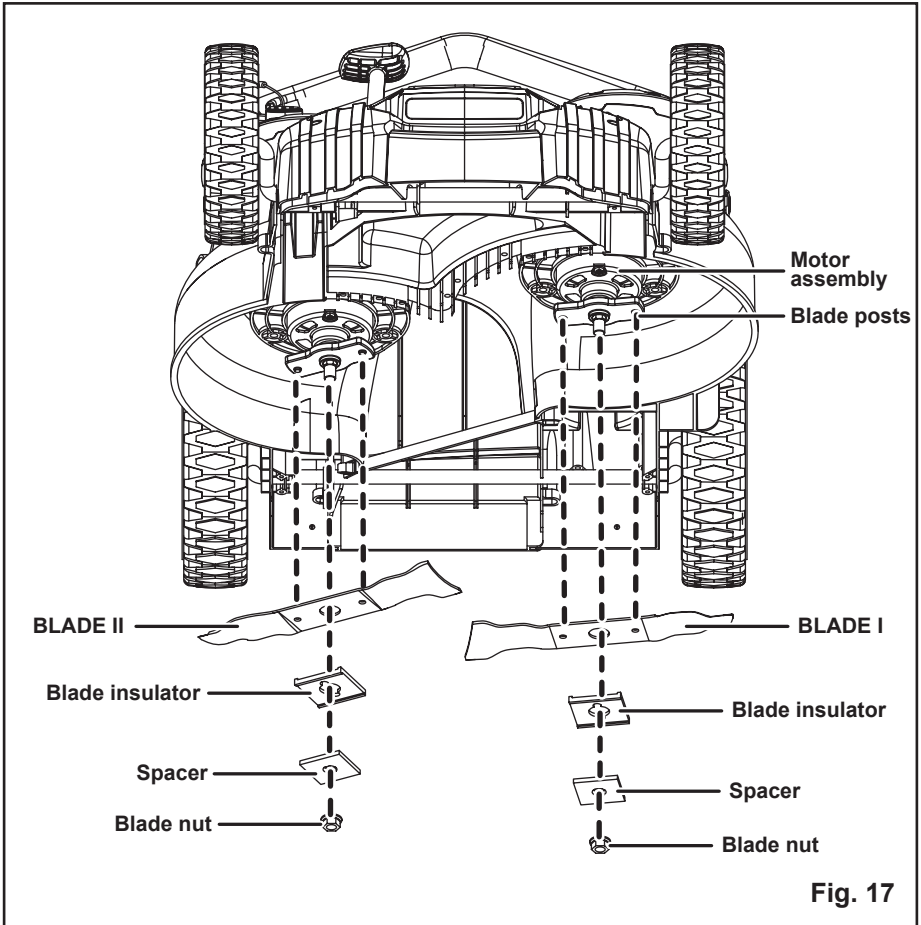

Fig. 16

# MAINTENANCE



- Replace the blade insulator and spacer, then thread the blade nut on the shaft and finger tighten.

*NOTE: Make certain all parts are replaced in the exact order in which they were removed.*

- For the **BLADE I**, torque the blade nut down counterclockwise using a torque wrench (not provided) to ensure the bolt is properly tightened. For the **BLADE II**, torque the blade nut down clockwise using a torque wrench (not provided) to ensure the bolt is properly tightened. The recommended torque for the blade nut is 350-400 in. lbs.

# MAINTENANCE

---

## **REPLACING THE BATTERY**

The mower battery is designed for maximum life; however, like all batteries, it will eventually need to be replaced.

Charge the new battery pack before use.

### **To install a new battery:**

- Remove the key.
- Carefully unlock and remove the battery pack.
- Install the new battery pack.
- Take the old battery pack to a recycling center that accepts lead acid/lithium ion batteries. Never dispose of battery in fire or regular household trash.

# MAINTENANCE

---

## CLEANING THE MOWER

---

### **⚠** WARNING

In order to reduce the risk of electric shock, do not expose the mower to water. The underside of the mower deck should be cleaned after each use, because grass clippings, leaves, dirt, and other debris will accumulate, which will cause rust and corrosion.

---

Remove any build-up of grass and leaves on or around the motor cover (do not use water). Occasionally wipe the mower clean with a dry cloth. If debris builds up on the underside of the mower during use, stop the motor, disconnect it from the battery, and then tilt the mower forward or on its side, and scrape it clean using an appropriate tool.

## STORING THE MOWER

The following steps should be taken in order to prepare the lawn mower for storage.

- Clean the mower as described in the previous section.
- Inspect the blade, and replace it or sharpen it, if required (refer to the Maintenance section).
- Lubricate the mower (refer to the Maintenance section).
- Store the mower in a dry, clean location. Do not store it next to corrosive materials, such as fertilizer or rock salt.
- Store the mower indoors, in a cool, dry place, out of the reach of children. Do not cover the lawn mower with a solid plastic sheet. Plastic coverings trap moisture around the mower, which causes rust and corrosion.
- The handle may be folded away completely for storage. (See Figure 2-3)

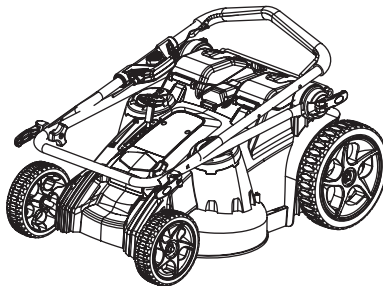

- Remove the battery and key, store it in a cool dry location, if possible. Charge the battery every two months when not in use in order to increase its life.

---

### **⚠** WARNING

This battery must be charged when in storage to maintain running life.

---

# SERVICE

---

- When servicing the mower, use only replacement parts that are available from the manufacturer. In order to obtain replacement parts, call the toll-free helpline, at 1-888-909-6757. The use of parts that do not meet the original equipment specifications may lead to improper performance, and may compromise safety.
- Before cleaning, repairing, or inspecting, verify that the blade and all moving parts have come to a complete stop. Remove the battery when making any adjustments or when any of the four wheels must be lifted off the ground.
- Follow the instructions for lubricating and changing accessories.
- Keep the handles dry, clean, and free of oil and grease.
- In order to reduce the risk of fire, keep the motor free of grass, leaves, and debris build-up.
- Check the blade and motor mounting bolts for proper tightness frequently. Visually inspect blade for damage (e.g., bent, cracked, or worn).
- For best and safest performance, maintain the mower with care. Keep the mower blade sharp and clean. Mower blades are sharp, and can cut. Wrap the blades or wear gloves, and use extra caution when servicing.
- Keep all nuts, bolts, and screws tight in order to be sure that the equipment is in safe working condition.
- Never tamper with safety devices. Check them regularly for proper operation.
- After striking a foreign object, stop the motor. Thoroughly inspect the mower for any damage. Repair any damage before operating the mower.
- The grass catcher components, discharge cover, and trail shield are subject to wear and damage, which could expose moving parts or allow objects to be thrown. As a safety precaution, check these components frequently, and immediately replace any parts that show signs of wear, or that are cracked or broken. Use original equipment manufacturer's (OEM) parts only, as listed in this manual.
- When it is not in use, store the mower indoors in a dry area, and out of the reach of children.

---

## **WARNING**

**ALWAYS REMOVE KEY AND BATTERY WHEN SERVICING OR TRANSPORTING THE MOWER.**

---

# ENVIRONMENTALLY SAFE BATTERY DISPOSAL

---

The batteries used in this mower's battery pack contain the following toxic and corrosive material: LITHIUM-ION.

---

## **WARNING**

Toxic materials must be disposed of in a specified manner in order to prevent contamination of the environment. Before disposing of damaged or worn out Lithium-Ion battery packs, contact your local waste disposal agency for information and specific instructions. Take the batteries to a local recycling and/or disposal centre that is certified for disposal. If the battery pack cracks or breaks, whether it leaks or not, do not recharge it and do not use it. Dispose of it and replace it with a new battery pack. **DO NOT ATTEMPT TO REPAIR IT!**

---

Follow these instructions in order to avoid injury and the risk of fire, explosion, or electric shock, and to avoid damage to the environment:

- Cover the battery's terminals with heavy-duty adhesive tape.
- Do not attempt to remove or destroy any of the components of the battery pack.
- Do not attempt to open the battery pack.
- If a leak develops, the electrolytes that are released are corrosive and toxic. Do not get the solution in the eyes or on the skin, and do not swallow it.
- Do not place batteries in regular household trash.
- DO NOT incinerate batteries.
- DO NOT place batteries where they will become part of any waste landfill or municipal solid waste stream.
- Dispose of batteries at a certified recycling or disposal centre.

# TROUBLESHOOTING

<b>PROBLEM</b>	<b>POSSIBLE CAUSE</b>	<b>SOLUTION</b>
The mower does not start.	The battery is not charged.	Charge the battery.
	The switch is defective.	Replace the switch (call the tollfree helpline, at 1-888-909-6757)
	Grass jammed at blade.	Remove battery; check under deck for jams.
	The battery is not attached to the motor.	Check the connection between the motor connector and the battery.
	Battery may require service or replacement.	Call toll free helpline, at 1-888-909-6757 or replace battery.
	Key is not installed.	Insert the key.
The mower cuts the grass unevenly.	The lawn is rough or uneven.	Check the mowing area.
	The cutting height is not set properly.	Move the wheels to a higher setting.
The mower does not mulch properly.	Wet grass clippings are sticking to the underside of the deck.	Wait until the grass dries before mowing.
	The mulching plug is missing.	Install the mulching plug.
The mower is hard to push.	The grass is too tall, or the cutting height is too low.	Raise the cutting height.
	The rear of the mower housing and the blade are dragging in thick grass.	Empty the grass clippings from the grass catcher bag.
The mower is excessively noisy and vibrates.	The motor shaft is bent.	Stop the motor, and inspect for damage.
	The blade is unbalanced.	Repair before restarting. If vibration persists, call the toll free helpline (1-888-909-6757)
The mower speeds up and slows down while in operation.	This is normal. Power Save feature automatically adjusts the cutting speed of the blades to match the application to give the best possible cut while maximizing run time and battery life.	None, this is normal.

# LIMITED FOUR-YEAR WARRANTY

---



GREENWORKS™ hereby warrants this product, to the original purchaser with **proof of purchase**, for a period of four (4) years against defects in materials, parts or workmanship. GREENWORKS™, at its own discretion will repair or replace any and all parts found to be defective, through normal use, free of charge to the customer. This warranty is valid only for units which have been used for personal use that have not been hired or rented for industrial/commercial use, and that have been maintained in accordance with the instructions in the owners' manual supplied with the product from new.

Battery carries a two (2) years warranty against defects in workmanship and materials. Batteries must be charged in accordance with the operator's manuals directions and regulations in order to be valid.

## ITEMS NOT COVERED BY WARRANTY:

1. Any part that has become inoperative due to misuse, commercial use, abuse, neglect, accident, improper maintenance, or alteration; or
2. The unit, if it has not been operated and/or maintained in accordance with the owner's manual; or
3. Normal wear, except as noted below;
4. Routine maintenance items such as lubricants, blade sharpening;
5. Normal deterioration of the exterior finish due to use or exposure.

## GREENWORKS HELPLINE (1 888 90WORKS):

Warranty service is available by calling our toll-free helpline, 9 a.m. to 5 p.m. EST. at **1 888 909 6757 (1 888 90WORKS)**.

## TRANSPORTATION CHARGES:

Transportation charges for the movement of any power equipment unit or attachment are the responsibility of the purchaser. It is the purchaser's responsibility to pay transportation charges for any part submitted for replacement under this warranty unless such return is requested in writing by GREENWORKS.



# EXPLODED VIEW

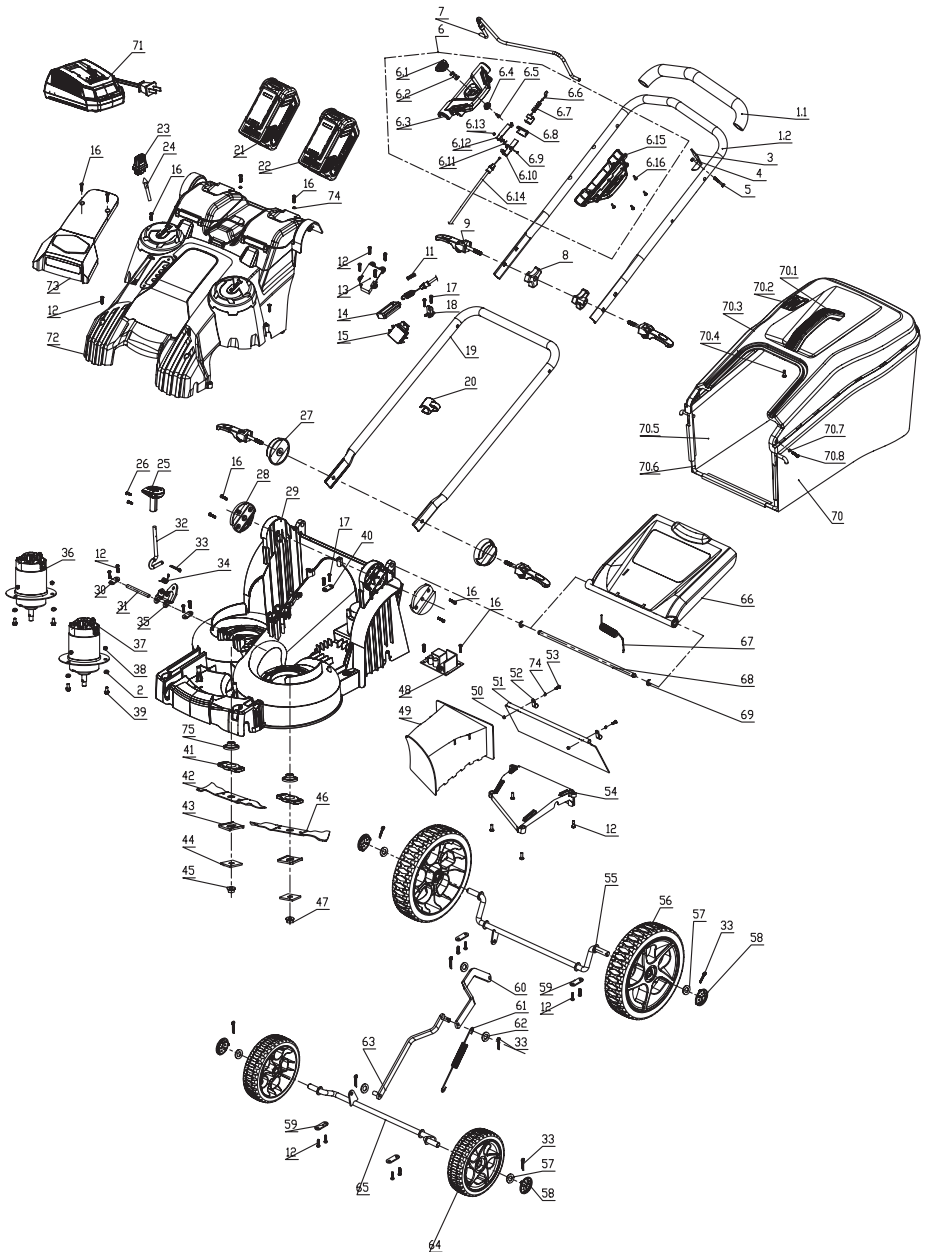

# PARTS LIST

ITEM NO.	PART NO.	DESCRIPTION	QTY
1	31104488	Upper handle assy.	1
1.1	34135486	Foam grip	1
1.2	33310470-2	Upper handle	1
2	32207115	Washer	6
3	33323250-1	Stop sheet	1
4	3220439	Lock nut M5	1
5	32208234A	Screw M5x30	1
6	31107486-1	Motor engagement box assy.	1
6.1	34136486	Start button	1
6.2	33401229	Spring	1
6.3	34122486	Upper cover, motor engagement box	1
6.4	34140486	Compressor	1
6.5	3220735N	Screw ST3x8-C	3
6.6	31901250	Start cable (short)	1
6.7	33318250	Tension spring	1
6.8	34118250	Block	1
6.9	32204250	Screw M3x20	1
6.10	33317250	Slide block	1
6.11	33316250	Torsion spring	1
6.12	33315250	Spring	1
6.13	3221305	Nut M3	1
6.14	31901486	Start cable (long)	1
6.15	34121486	Lower cover, motor engagement box	1
6.16	32204113D	Screw ST4.2x20-C	4
7	33305469-3	Motor bail	1
8	34106467-1	Knob	2
9	31102467-2	Cam lock assy.	4
10	33324250	Cord guide	1
11	33332250	Spring	1
12	32204113D	Screw ST4.2x20-C	4
13	34119486	Upper cover, switch box	1
14	34114250	Slide block, switch box	1
15	36301289	Switch	1
16	32201572	Screw ST4.2x14	4
17	32202517	Screw ST4x10	5
18	33314486	Switch box bracket	1
19	33315486	Lower handle	1
20	34135469A	Cord guide	1
21	31104975	40V 146Wh battery pack	1
22	31103976	40V 73Wh battery pack	1
23	31201470	Key	1
24	34903250	knit	15 cm

# PARTS LIST

---

ITEM NO.	PART NO.	DESCRIPTION	QTY
25	34109470-1	Height adjustment knob	1
26	32201470	Srew M3x8	2
27	34105470-2	Cam lock cover	2
28	34123486	Cam lock base	2
29	34105486	Deck	1
30	33306470	Height adjustment plate	2
31	33201470	Height adjustment alxe	1
32	33305486	Height adjustment lever	1
33	3290135	Pin $\phi$ 2.5	8
34	33901470	Height adjustment torsion spring	1
35	33305470	Height adjustment bracket	1
36	36101486A	Motor, 5335F-40V/20"	1
37	36101486	Motor, 5335Z-40V/20"	1
38	3220537	Lock nut M6	6
39	3220135	Bolt M6x25	6
40	3410403	Wire clip	1
41	34106486	Blade holder	2
42	33308486	Reverse blade	1
43	34107486	Blade insulator	2
44	33309486	Spacer	2
45	3220535A	Nut M10x1.25	1
46	33307486	Blade	1
47	3221037A	Nut M10x1.25	1
48	36202486-1	Power switch board	1
49	34141486	Mulching plug	1
50	3221237	Lock nut M4	2
51	34127486-1	Rear shield	1
52	3330490-1	Wire clip	2
53	3220511D	Screw M4x12.5	2
54	34128486	Rear baffle	1
55	33302486	Rear wheel axle	1
56	34102486	10" wheel	2
57	3220898	Washer	4
58	34106488	Wheel cover	4
59	33318486	Wheel alxe washer	4
60	33304486	Link bar (rear)	1
61	33306486	Height adjustment tension spring	1
62	32904131-1	Washer	3
63	33303486	Link bar (front)	1
64	34103486	7" wheel	2

# PARTS LIST

---

ITEM NO.	PART NO.	DESCRIPTION	QTY
65	33311486	Front wheel axle	1
66	34126486	Rear cover	1
67	33904486	Torsion spring, rear cover	1
68	33317486	Rear cover rod	1
69	3290506	Retaining ring 8	2
70	31108486	Grass catcher bag assy.	1
70.1	34132486	Catcher bag handle	1
70.2	34133486	Indicator	1
70.3	34130486	Grass catcher bag cover	1
70.4	32201572	Screw ST4.2x14	2
70.5	34125486	Grass catcher bag	1
70.6	33316486	Grass catcher frame	1
70.7	3290305	Washer	2
70.8	3220511D	Screw M4x12.5	2
71	31102998	40 Charger	1
72	31109486	Motor cover assy.	1
73	34111486	Upper cover	1
74	3290305	Washer	4
75	33320486	Spindle guard	2



**TOLL-FREE HELPLINE: 1-888-90WORKS** (888.909.6757)

Rev: 01 (11-15-12)

 Printed in China on 100% Recycled Paper