



655 EISENHOWER DRIVE
OWATONNA, MN 55060-0995 USA
PHONE: (507) 455-7000
TECH. SERV.: (800) 533-6127
FAX: (800) 955-8329
ORDER ENTRY: (800) 533-6127
FAX: (800) 283-8665
INTERNATIONAL SALES: (507) 455-7223
FAX: (507) 455-7063

Form No. 555366

Parts List &
Operating Instructions
for:

6980

Heavy-Duty Brake Drum Puller

PARTS LIST

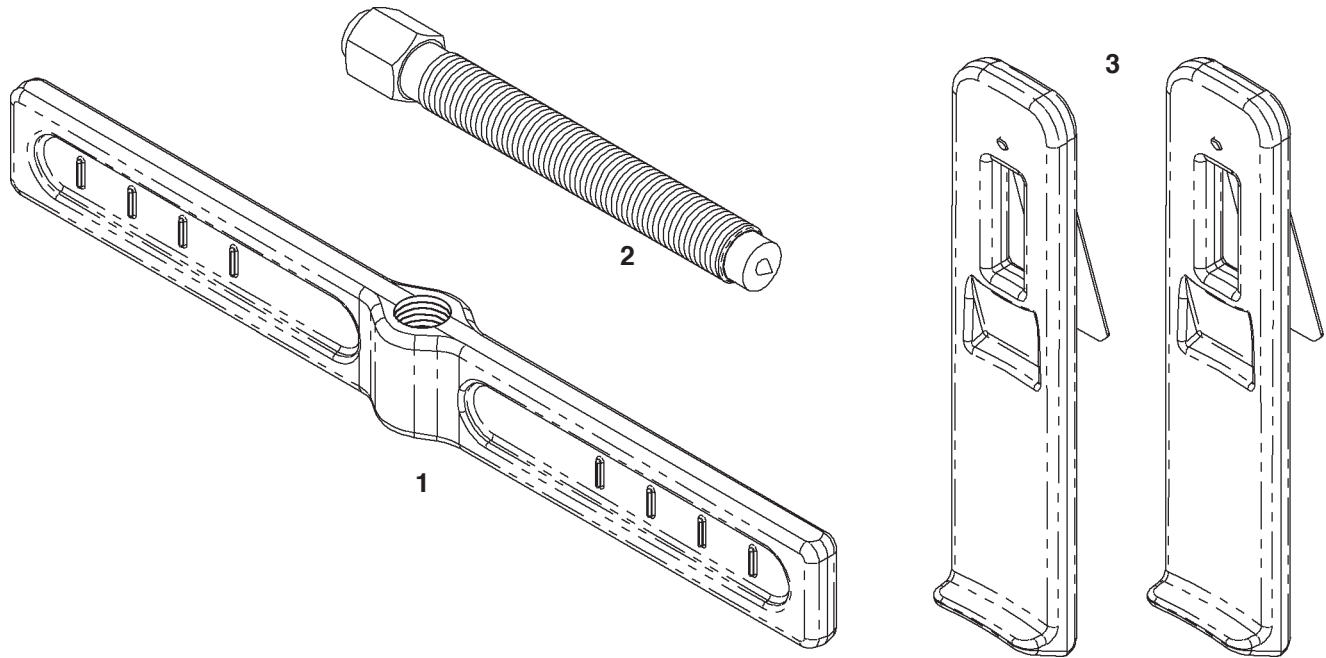

Item No.	Part No.	Qty.	Description
1	554297	1	Crossbar
2	554303	1	Forcing Screw
3	554306	2	Puller Jaw Assembly

PARTS INCLUDED BUT NOT SHOWN

556474 1 Strap

© 2010 SPX

Sheet No. 1 of 1

Issue Date: Rev. A, March 5, 2010



WARNING: To prevent personal injury, wear eye protection that meets ANSI Z87.1 and OSHA standards.

OPERATION

1. Refer to the vehicle service manual for instructions on using an appropriate lifting device to hoist the vehicle off the ground. Lift the vehicle just far enough to remove the wheel and tire.
2. After removing the wheel, completely thread two lug nuts back onto two opposing wheel studs. Back off the lug nuts three or four turns to allow the drum to be pulled away from, but not fall off, the wheel hub. See Figure 1.
3. Estimate the diameter of the brake drum. Using the marks on the puller crossbar as a guide, set the jaws an equal distance apart from the center on each side of the brake drum.
4. With the forcing screw at the center of the wheel hub, position the puller jaws in the groove between the brake drum and the backing plate. Adjust the jaws on the crossbar as needed to fit.
5. Verify the jaws have good contact with the drum, and hand-tighten the forcing screw to the wheel hub.
6. Place the strap (provided) over the puller and brake drum. Position it around the outer edge of the drum and within the tabs of the jaws. Cinch the strap tightly in place. See Figure 2.
7. Using a ratchet or impact wrench, turn the forcing screw inward just enough to remove the brake drum.
8. Remove the strap and the puller from the brake drum. Remove the lug nuts and remove the brake drum.

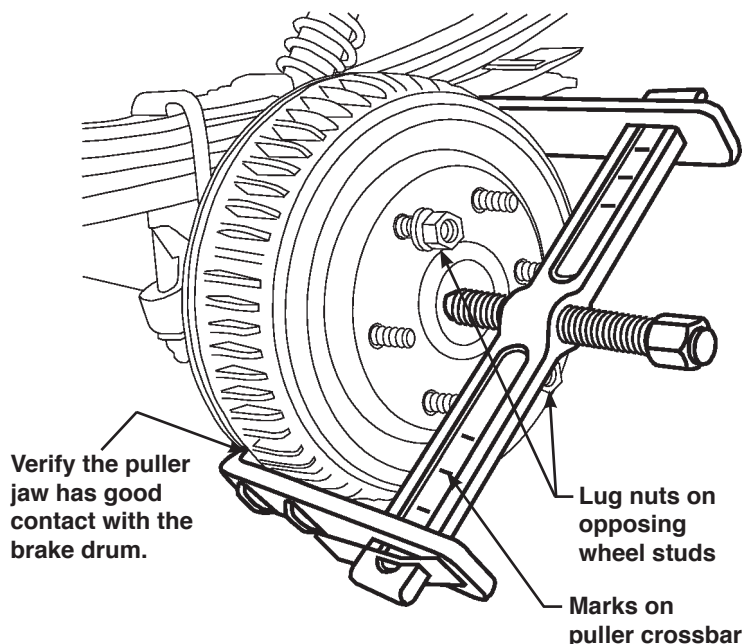

Figure 1

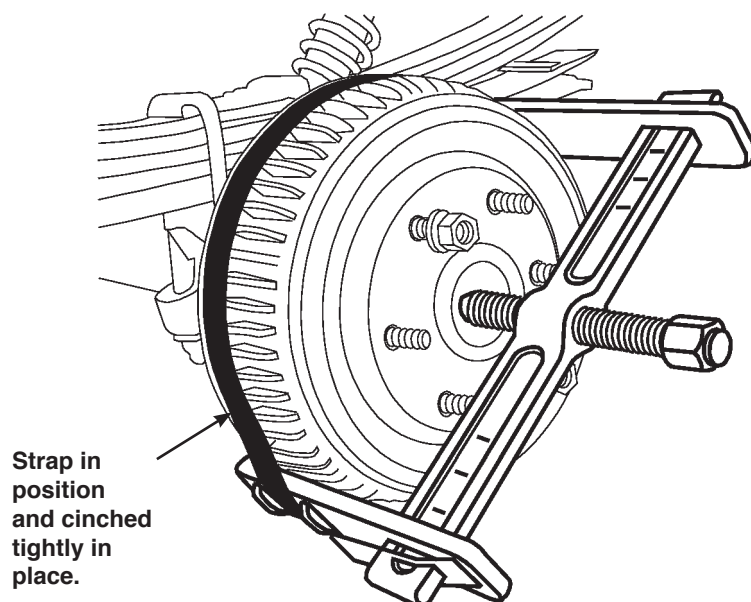

Figure 2