

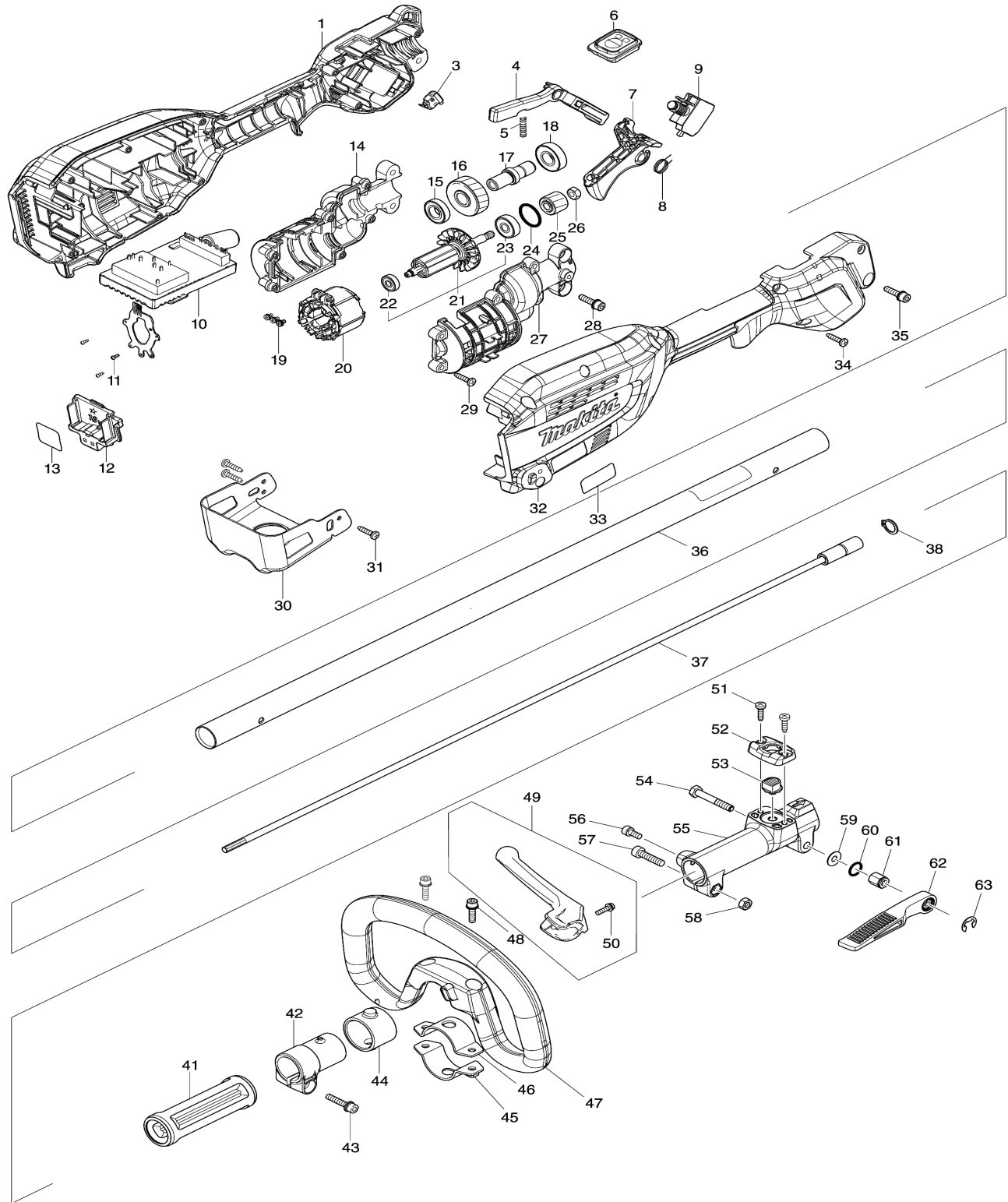

XUX02SMX4



Products with multiple versions are listed in subsiding order with the newest version on top not indented.

Section	Fig. No.	Part No.	Description	XUX02SM1X4	Tech Bulletin	Notes
1	1	183S11-5	GRIP HOUSING SET	1		INC. 32
1	3	632G61-0	SWITCH UNIT	1		
1	4	412863-6	LOCK OFF LEVER	1		
1	5	233101-1	COMPRESSION SPRING 4	1		
1	6	140W41-3	SWITCH CIRCUIT COMPLETE	1		
1	7	459758-2	SWITCH LEVER	1		
1	8	233622-3	TORSION SPRING 12	1		
1	9	651494-8	SWITCH C3JW-1A-PA-2	1		
1	10	620D91-5	CONTROLLER	1		
1	11	266490-9	TAPPING SCREW PT 2X6	3		
1	12	644809-6	TERMINAL	1		
1	13	857X04-5	XUX02 SERIAL NO. LABEL	1		
1	14	183R80-0	MOTOR HOUSING SET	1		INC. 27
1	15	210243-8	BALL BEARING 6901ZZ	1		
1	16	227848-7	HELICAL GEAR 33	1		
1	17	327719-9	SPINDLE HUB	1		
1	18	210244-6	BALL BEARING 6001ZZ	1		
1	19	652069-6	FLAT HEAD SCREW M3X6	3		
1	20	629A28-1	STATOR	1		
1	21	519654-7	ROTOR ASS'Y	1		INC. 22,23
1	22	210235-7	BALL BEARING 625ZZ	1		
1	23	210236-5	BALL BEARING 627ZZ	1		
1	24	213843-3	O-RING 21	1		
1	25	227849-5	HELICAL GEAR 16	1		
1	26	252153-3	HEX. NUT M6-10	1		
1	27	183R80-0	MOTOR HOUSING SET	1		INC. 14
1	28	922234-4	H.S.H.BOLT M5X20 WITH WG	2		
1	29	266326-2	TAPPING SCREW 4X18	6		
1	30	347765-6	BATTERY GUARD	1		
1	31	266326-2	TAPPING SCREW 4X18	3		
1	32	183S11-5	GRIP HOUSING SET	1		INC. 1
1	33	857W98-4	XUX02 NAME PLATE	1		

Products with multiple versions are listed in subsiding order with the newest version on top not indented.

Section	Fig. No.	Part No.	Description	XUX02SM1X4	Tech Bulletin	Notes
1	34	266326-2	TAPPING SCREW 4X18	10		
1	35	922234-4	H.S.H.BOLT M5X20 WITH WG	1		
1	36	141B21-6	SHAFT PIPE B COMPLETE	1		
1	37	141238-9	SHAFT B COMPLETE	1		
1	38	961052-5	RETAINING RING S-12	1		
1	41	451601-1	SPACER 24	1		
1	42	457269-1	PIPE HOLDER 24	1		
1	43	922244-1	H.S.H.BOLT M5X25 WITH WG	1		
1	44	424942-8	DAMPER	1		
1	45	347114-7	LOWER CLAMP 35	1		
1	46	347113-9	UPPER CLAMP 35	1		
1	47	457772-2	LOOP HANDLE	1		
1	48	922234-4	H.S.H.BOLT M5X20 WITH WG	2		
1	49	144315-6	BARRIER COMPLETE	1		INC. 50
1	50	911128-8	P.H.SCREW M4X16 WITH WR	1		
1	51	266034-5	TAPPING SCREW CT 4X16	2		
1	52	452840-6	RELEASE BUTTON COVER	1		
1	53	452839-1	RELEASE BUTTON	1		
1	54	265596-0	HEX.BOLT M6X40	1		
1	55	318750-6	JOINT 24	1		
1	56	922211-6	H.S.H.BOLT M5X12 WITH W	1		
1	57	922342-1	HEX. SOCKET HEAD BOLT M6X25	1		
1	58	931302-2	HEX. NUT M6	1		
1	59	253332-6	THIN WASHER 6	1		
1	60	213105-9	O RING 11	1		
1	61	252159-1	HEX. NUT M6	1		
1	62	272268-0	LEVER 94	1		
1	63	961014-3	STOP RING E-8	1		
1	65	443170-6	FELT	1		

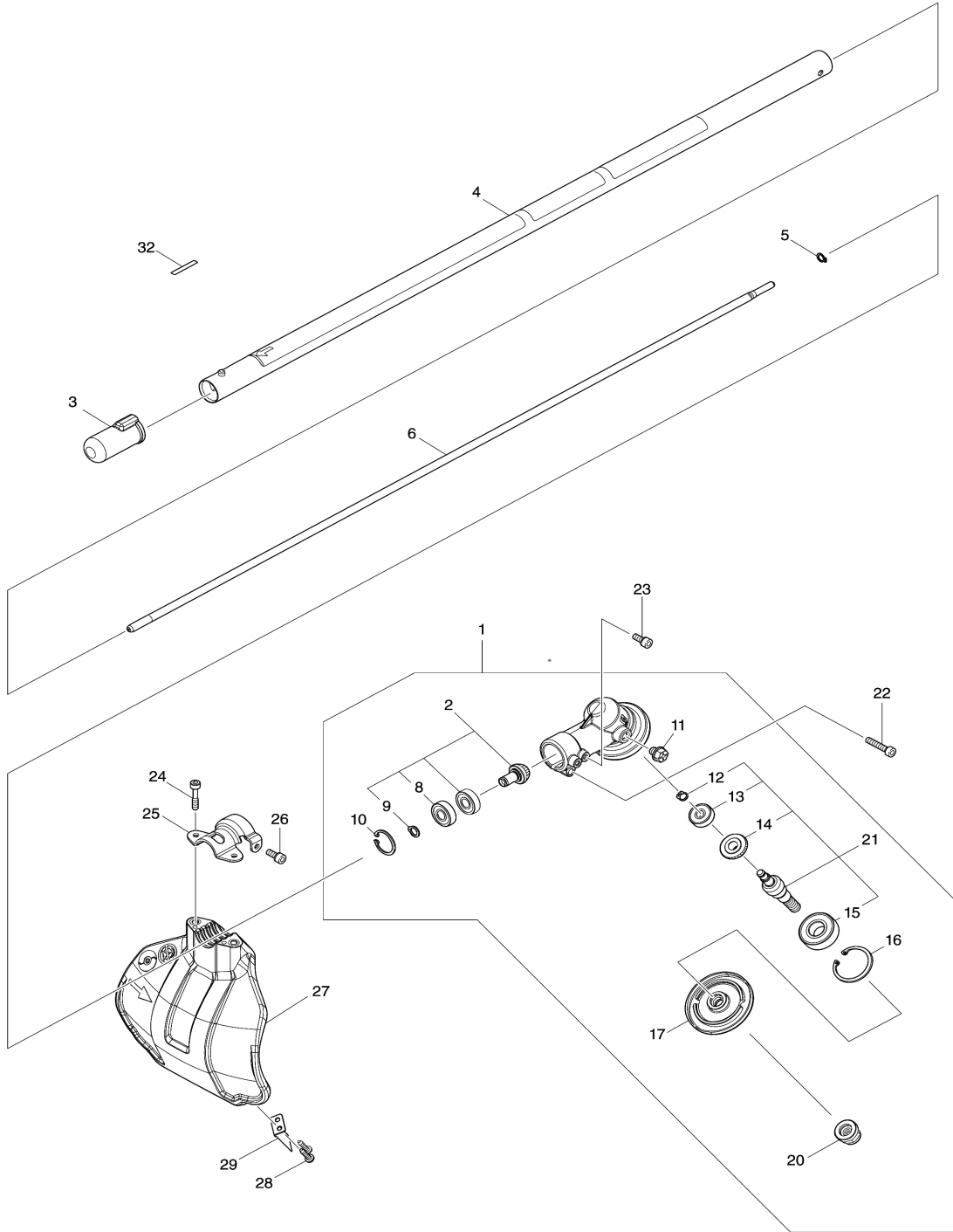

Products with multiple versions are listed in subsiding order with the newest version on top not indented.

Section	Fig. No.	Part No.	Description	XUX02SM1X4	Tech Bulletin	Notes
2	1	127710-5	GEAR CASE ASSEMBLY US	1		INC. 2,10,11,16,17,20,21
2	2	136374-4	SPIRAL BEVEL GEAR ASS'Y	1		INC. 8,9
2	3	424434-7	CAP 24	1		
2	4	140Y53-8	SHAFT PIPE A COMPLETE A	1		
2	5	961003-8	RETAINING RING S-7	1		
2	6	327723-8	SHAFT A	1		
2	8	210157-1	BALL BEARING 609ZZ	2		
2	9	259071-6	RETAINING RING (EXT) S-9	1		
2	10	259072-4	RETAINING RING (INT)R-24	1		
2	11	265590-2	+HEX.BOLT M8X10 WITH R	1		
2	12	259070-8	RETAINING RING (EXT) S-7	1		
2	13	210030-5	BALL BEARING 627ZZ	1		
2	14	226988-8	SPIRAL BEVEL GEAR 19	1		
2	15	211228-7	BALL BEARING 6202DDW	1		
2	16	259069-3	RETAINING RING (INT) R-35	1		
2	17	140N88-3	RECEIVE WASHER COMPLETE	1		
2	20	252236-9	HEX. LOCK NUT M10-17	1		
2	21	136375-2	CUTTER SHAFT ASS'Y	1		INC. 12-15
2	22	922242-5	HEX. SOCKET HEAD BOLT M5X25	1		
2	23	922216-6	HEX. SOCKET HEAD BOLT M5X14	1		
2	24	251513-6	H.S.H.BOLT M5X25	2		
2	25	347107-4	PROTECTOR CLAMP 24	1		
2	26	922216-6	HEX. SOCKET HEAD BOLT M5X14	1		
2	27	412968-2	PROTECTOR N 330	1		
2	28	266326-2	TAPPING SCREW 4X18	2		
2	29	346855-2	CUTTER	1		
2	32	814A82-0	DATE CODE LABEL	1		

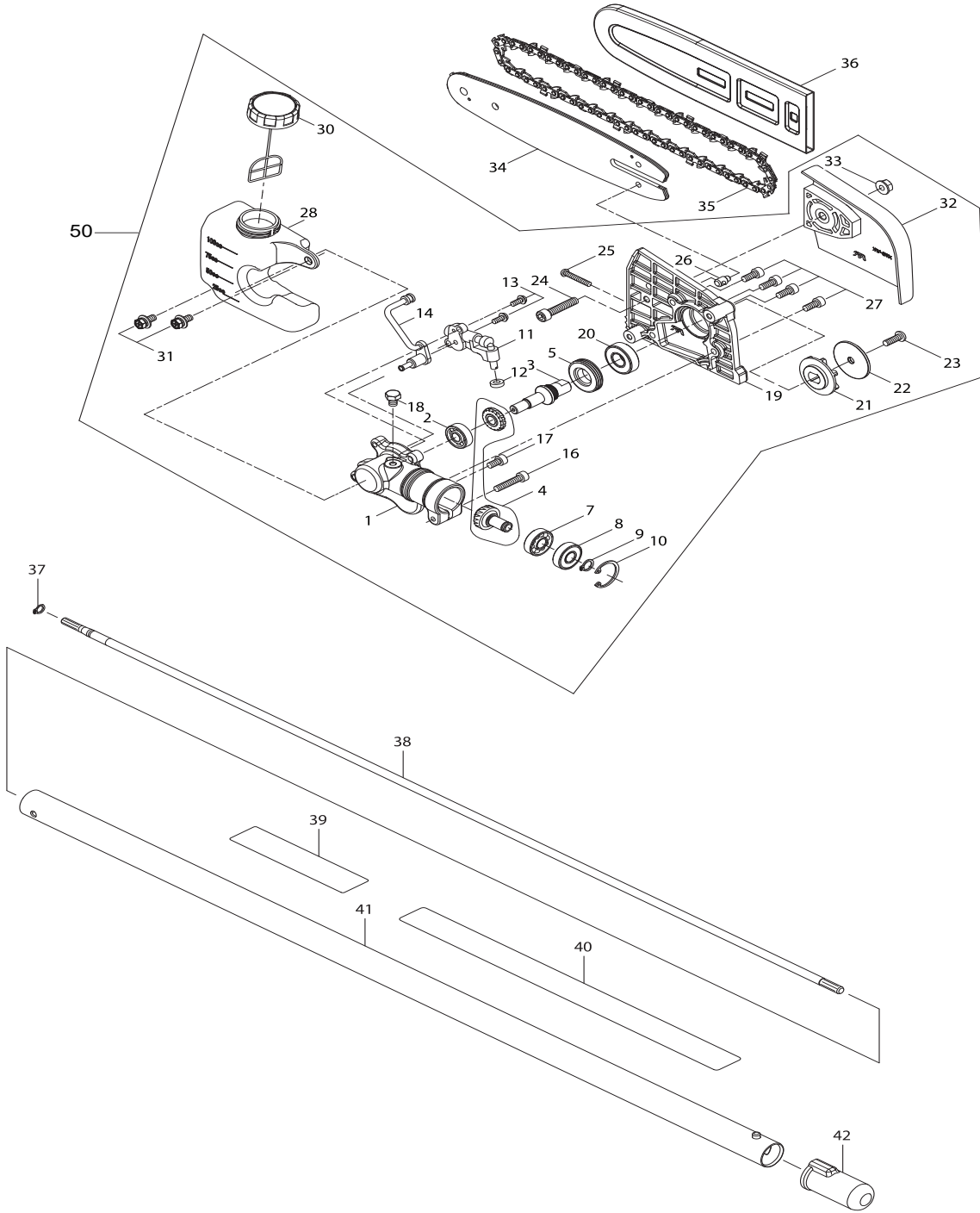

Products with multiple versions are listed in subsiding order with the newest version on top not indented.

Section	Fig. No.	Part No.	Description	XUX02SM1X4	Tech Bulletin	Notes
3	1	XTM0000001	GEAR CASE A	1		
3	2	XTM0000002	BALL BEARING 608	1		
3	3	XTM0000024	GEAR SHAFT	1		
3	4	XTM0000004	BEVEL GEAR SHAFT	1		
3	5	XTM0000005	WORM WHEEL	1		
3	7	XTM0000006	BALL BEARING 609	1		
3	8	XTM0000007	BALL BEARING 609Z	1		
3	9	961005-4	RETAINING RING S-9	1		
3	10	962103-7	RETAINING RING R-24	1		
3	11	XTM0000025	OIL PUMP	1		
3	12	XTM0000009	SEAL	1		
3	13	911111-5	PAN HEAD SCREW M4X10	2		
3	14	XTM0000010	OIL PIPE ASSY	1		
3	16	922242-5	HEX. SOCKET HEAD BOLT M5X25	1		
3	17	922207-7	HEX. SOCKET HEAD BOLT M5X10	1		
3	18	XTM0000011	HB BOLT 6X8	1		
3	19	XTM0000027	GEAR CASE B	1		
3	20	XTM0000013	BALL BEARING 6001DDW	1		
3	21	XTM0000014	SPROCKET	1		
3	22	XTM0000015	SPROCKET WASHER	1		
3	23	XTM0000016	H.S. BOTTOM HEAD SCREW M6X15	1		
3	24	922352-8	HEX. SOCKET HEAD BOLT M6X30	1		
3	25	XTM0000017	ADJUSTER SCREW M4X25	1		
3	26	XTM0000018	ADJUSTER	1		
3	27	922212-4	HEX SOCKET HEAD BOLT M5X12	4		
3	28	XTM0000019	OIL TANK ASS'Y	1		
3	30	XTM0000020	TANK CAP ASS'Y	1		
3	31	XTM0000021	H.S.H. BOLT M5X12SW	2		
3	32	XTM0000022	CHAIN COVER	1		
3	33	XTM0000023	FLANGE NUT M6	1		
3	34	E-00050	GUIDE BAR 10	1		
3	35	196725-3	SAW CHAIN SET	1		

Products with multiple versions are listed in subsiding order with the newest version on top not indented.

Section	Fig. No.	Part No.	Description	XUX02SM1X4	Tech Bulletin	Notes
3	36	452094-5	GUIDE BAR CASE	1		
3	37	961003-8	RETAINING RING S-7	1		
3	38	326088-5	SHAFT A	1		
3	39	819312-8	MAKITA LOGO LABEL	1		
3	40	809J24-1	CAUTION LABEL	1		
3	41	141106-6	SHAFT A COMPLETE	1		
3	42	424434-7	CAP 24	1		
3	50	127300-4	POLE SAW HEAD ASSY	1		