

# WIRING INSTRUCTIONS

TITLE

**1/2" POWER PACK DRILL MOTOR**

BULLETIN  
**58-01-0402**

MILWAUKEE ELECTRIC TOOL CORP. 13135 WEST LISBON RD. BROOKFIELD, WIS.

DATE  
Oct. '99

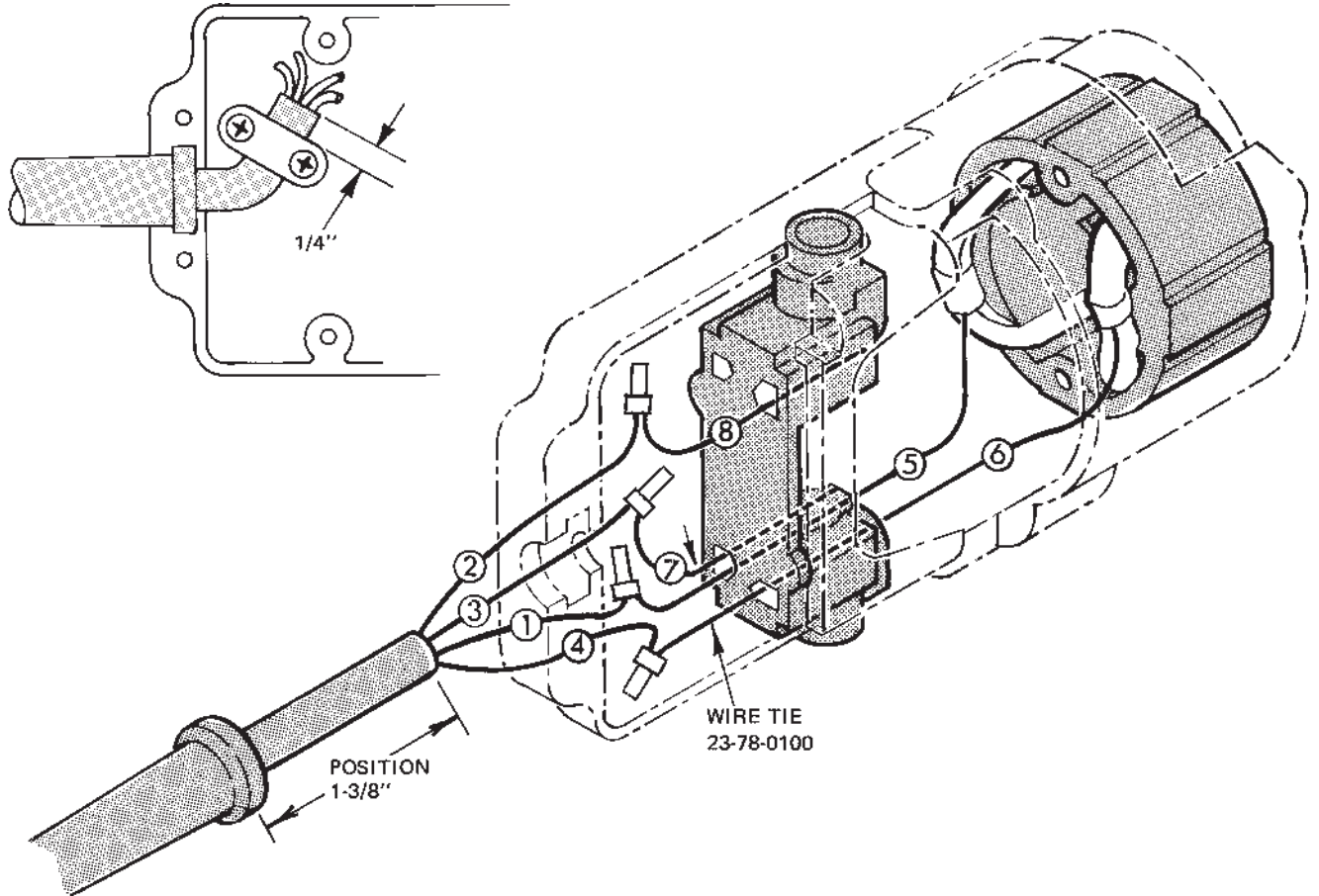

**NOTE:**

All lead lengths are before stripping.  
All field leads are to be measured from and perpendicular to laminations.  
All leads must be held to  $\pm 1/8$ ".

**WIRING SPECIFICATIONS**

Wire No.	Wire Color	Origin or Part No.	Gauge	Length	Terminals, Connectors and End Wire Preparation
1	White	Cord	--	3-3/4"	Strip 1/2" for C1
2	Red	Cord	--	3-3/4"	Strip 1/2" for C1
3	Blue	Cord	--	3-3/4"	Strip 1/2" for C1
4	Black	Cord	--	3-3/4"	Strip 1/2" for C1
5	Black	Field	--	6"	Strip 1/2" for C1
6	Red	Field	--	6"	Strip 1/2" for C1
7	Black	--	18	5"	Strip 3/8" for T1 / Strip 1/2" for C1
8	Yellow	--	18	5"	Strip 3/8" for T1 / Strip 1/2" for C1

BULK LEAD WIRE - BULLETIN 58-01-0003

**TERMINAL DESCRIPTION**

Code	Part No.	Qty.
T1	22-44-0090	2

**CONNECTOR DESCRIPTION**

Code	Part No.	Qty.
C1	22-56-0160	4