



**Astro Pneumatic
Tool Company**

372 Old US Highway 52 South
Mount Airy, NC 27030

Model:
888S

Product Type:

**MINI STRAIGHT
LINE SANDER**

PARTS BREAKDOWN

Call 1.800.221.9705 for questions concerning performance of the product or other inquiries.

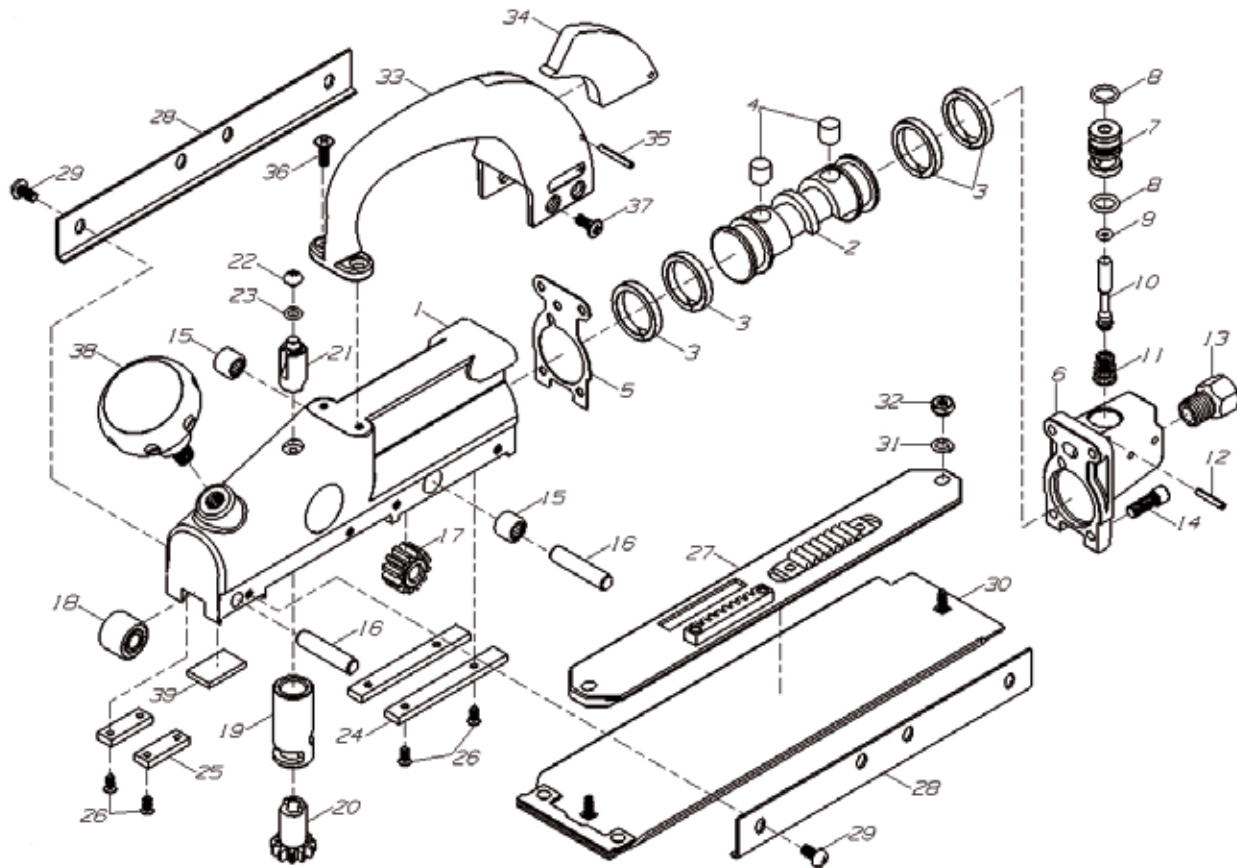

Parts List

Part No.	Description	Qty
888S-01	Housing Assembly	1
888S-02	Piston	1
888S-03	Piston Ring	4
888S-04	Plug	2
888S-05	Gasket	1
888S-06	Rear Cover	1
888S-07	Bushing	1
888S-08	O-Ring	2
888S-09	O-Ring	1
888S-10	Valve Stem	1
888S-11	Spring	1
888S-12	Pin	1
888S-13	Inlet	1
888S-14	Screw	4
888S-15	Bearing	2
888S-16	Gear Shaft	2
888S-17	Gear	1
888S-18	Roller	1
888S-19	Valve	1
888S-20	Gear	1

Part No.	Description	Qty
888S-21	Adjusting Shaft	1
888S-22	Screw	1
888S-23	O-Ring	1
888S-24	Wear Plate	2
888S-25	Wear Plate	2
888S-26	Screw	8
888S-27	Carrier Plate	1
888S-28	Strap	2
888S-29	Screw	8
888S-30	Pad	1
888S-31	Washer	2
888S-32	Nut	2
888S-33	Handle	1
888S-34	Trigger	1
888S-35	Pin	1
888S-36	Screw	2
888S-37	Screw	4
888S-38	Knob	1
888S-39	Muffler	1