

POWERMATIC®

WMH | TOOL GROUP

Operating Instructions and Parts Manual Oscillating Edge Sander

Model OES9138



WMH TOOL GROUP

2420 Vantage Drive
Elgin, Illinois 60123
Ph.: 800-274-6848
www.wmhtoolgroup.com

Part No. M-0460268
Revision C 4/04
Copyright © WMH Tool Group

This manual has been prepared for the owner and operators of a Powermatic OES9138 Oscillating Edge Sander. Its purpose, aside from machine operation, is to promote safety using accepted operating and maintenance procedures. To obtain maximum life and efficiency from your edge sander and to aid in using it safely, please read this manual thoroughly and follow the instructions carefully.

Warranty and Service

WMH Tool Group warrants every product it sells. If one of our tools needs service or repair, one of our Authorized Repair Stations located throughout the United States can provide quick service or information.

In most cases, a WMH Tool Group Repair Station can assist in authorizing repair work, obtaining parts, or perform routine or major maintenance repair on your Powermatic product.

For the name of an Authorized Repair Station in your area, please call 1-800-274-6848, or visit our web site at www.wmhtoolgroup.com

More Information

Remember, WMH Tool Group is consistently adding new products to the line. For complete, up-to-date product information, check with your local WMH Tool Group distributor, or visit our web site at www.wmhtoolgroup.com

WMH Tool Group Warranty

WMH Tool Group makes every effort to assure that its products meet high quality and durability standards and warrants to the original retail consumer/purchaser of our products that each product be free from defects in materials and workmanship as follows: 1 YEAR LIMITED WARRANTY ON ALL PRODUCTS UNLESS SPECIFIED OTHERWISE. This Warranty does not apply to defects due directly or indirectly to misuse, abuse, negligence or accidents, normal wear-and-tear, repair or alterations outside our facilities, or to a lack of maintenance.

WMH TOOL GROUP LIMITS ALL IMPLIED WARRANTIES TO THE PERIOD SPECIFIED ABOVE, BEGINNING FROM THE DATE THE PRODUCT WAS PURCHASED AT RETAIL. EXCEPT AS STATED HEREIN, ANY IMPLIED WARRANTIES OR MERCHANTABILITY AND FITNESS ARE EXCLUDED. SOME STATES DO NOT ALLOW LIMITATIONS ON HOW LONG THE IMPLIED WARRANTY LASTS, SO THE ABOVE LIMITATION MAY NOT APPLY TO YOU. IN NO EVENT SHALL WMH TOOL GROUP BE LIABLE FOR DEATH, INJURIES TO PERSONS OR PROPERTY, OR FOR INCIDENTAL, CONTINGENT, SPECIAL, OR CONSEQUENTIAL DAMAGES ARISING FROM THE USE OF OUR PRODUCTS. SOME STATES DO NOT ALLOW THE EXCLUSION OR LIMITATION OF INCIDENTAL OR CONSEQUENTIAL DAMAGES, SO THE ABOVE LIMITATION OR EXCLUSION MAY NOT APPLY TO YOU.

To take advantage of this warranty, the product or part must be returned for examination, postage prepaid, to an Authorized Repair Station designated by our office. Proof of purchase date and an explanation of the complaint must accompany the merchandise. If our inspection discloses a defect, we will either repair or replace the product at our discretion, or refund the purchase price if we cannot readily and quickly provide a repair or replacement. We will return the repaired product or replacement at WMH Tool Group's expense, but if it is determined there is no defect, or that the defect resulted from causes not within the scope of WMH Tool Group's warranty, then the user must bear the cost of storing and returning the product. This warranty gives you specific legal rights; you may also have other rights, which vary from state to state.

WMH Tool Group sells through distributors only. Members of the WMH Tool Group reserve the right to effect at any time, without prior notice, alterations to parts, fittings and accessory equipment, which they may deem necessary for any reason whatsoever.

Table of Contents

Warranty and Service	2
Warning.....	4
Introduction.....	6
Specifications	6
Features of the OES9138 Edge Sander	7
Unpacking	8
Contents of the Shipping Container	8
Assembly.....	8
Control Switch Bracket	9
Dust Collection.....	9
Grounding Instructions.....	9
230 Volt Operation	10
Test Run After Wiring	11
Converting to 460 Volt.....	11
Extension cords.....	11
Adjustments.....	11
Main Table Positioning	11
Main Table Tilting.....	12
Table/Belt Clearance.....	12
Miter Gauge	12
End Table	12
End Guard.....	13
Replacing Sanding Belt	13
Tracking Adjustment.....	13
Operating Controls.....	14
Operation.....	14
Maintenance.....	15
Lubrication	15
Optional Accessories	19
Replacement Parts	19
Parts List: Base Assembly	20
Base Assembly	21
Parts List: Drive Unit.....	22
Drive Unit.....	23
Parts List: Tracking and Belt Release Unit.....	24
Tracking and Belt Release Unit	25
Parts List: Table Assembly	26
Table Assembly.....	27
Parts List: Contour Sanding Unit.....	28
Contour Sanding Unit	29
Electrical Connections – 1 Phase.....	30
Electrical Connections – 3 Phase.....	31



Warnings

1. Read and understand the entire owners manual before attempting assembly or operation.
2. Read and understand the warnings posted on the machine and in this manual. Failure to comply with all of these warnings may cause serious injury.
3. Replace the warning labels if they become obscured or removed.
4. This edge sander is designed and intended for use by properly trained and experienced personnel only. If you are not familiar with the proper and safe operation of an edge sander, do not use until proper training and knowledge have been obtained.
5. Do not use this edge sander for other than its intended use. If used for other purposes, WMH Tool Group disclaims any real or implied warranty and holds itself harmless from any injury that may result from that use.
6. Always wear approved safety glasses/face shields while using this edge sander. Everyday eyeglasses only have impact resistant lenses; they are not safety glasses.
7. Before operating this edge sander, remove tie, rings, watches and other jewelry, and roll sleeves up past the elbows. Remove all loose clothing and confine long hair. Non-slip footwear or anti-skid floor strips are recommended. Do **not** wear gloves.
8. Wear ear protectors (plugs or muffs) during extended periods of operation.
9. Some dust created by power sanding, sawing, grinding, drilling and other construction activities contain chemicals known to cause cancer, birth defects or other reproductive harm. Some examples of these chemicals are:
 - Lead from lead based paint.
 - Crystalline silica from bricks, cement and other masonry products.
 - Arsenic and chromium from chemically treated lumber.Your risk of exposure varies, depending on how often you do this type of work. To reduce your exposure to these chemicals, work in a well-ventilated area and work with approved safety equipment, such as face or dust masks that are specifically designed to filter out microscopic particles.
10. Do not operate this machine while tired or under the influence of drugs, alcohol or any medication.
11. Make certain the switch is in the **OFF** position before connecting the machine to the power supply.
12. Make certain the machine is properly grounded.
13. Make all machine adjustments or maintenance with the machine unplugged from the power source.
14. Remove adjusting keys and wrenches. Form a habit of checking to see that keys and adjusting wrenches are removed from the machine before turning it on.
15. Keep safety guards in place at all times when the machine is in use. If removed for maintenance purposes, use extreme caution and replace the guards immediately.
16. Check damaged parts. Before further use of the machine, a guard or other part that is damaged should be carefully checked to determine that it will operate properly and perform its intended function. Check for alignment of moving parts, binding of moving parts, breakage of parts, mounting and any other conditions that may affect its operation. A guard or other part that is damaged should be properly repaired or replaced.
17. Provide for adequate space surrounding work area and non-glare, overhead lighting.
18. Keep the floor around the machine clean and free of scrap material, oil and grease.
19. Keep visitors a safe distance from the work area. **Keep children away.**



Warnings

20. Make your workshop child proof with padlocks, master switches or by removing starter keys.
21. Give your work undivided attention. Looking around, carrying on a conversation and “horse-play” are careless acts that can result in serious injury.
22. Maintain a balanced stance at all times so that you do not fall or lean against the sanding belt or other moving parts. Do not overreach or use excessive force to perform any machine operation.
23. Use the right tool at the correct speed and feed rate. Do not force a tool or attachment to do a job for which it was not designed. The right tool will do the job better and safer.
24. Use recommended accessories; improper accessories may be hazardous.
25. Make sure the work piece is stabilized during operation. Use the miter gauge whenever possible.
26. Turn off the machine before cleaning. Use a brush or compressed air to remove chips or debris — do not use your hands.
27. Do not stand on the machine. Serious injury could occur if the machine tips over.
28. Never leave the machine running unattended. Turn the power off and do not leave the machine until it comes to a complete stop.
29. Remove loose items and unnecessary work pieces from the area before starting the machine.

Familiarize yourself with the following safety notices used in this manual:

CAUTION

This means that if precautions are not heeded, it may result in minor injury and/or possible machine damage.

WARNING

This means that if precautions are not heeded, it may result in serious injury or possibly even death.

- - SAVE THESE INSTRUCTIONS - -

Introduction

This manual is provided by Powermatic covering the safe operation and maintenance procedures for a Model OES9138 Oscillating Edge Sander. This manual contains instructions on installation, safety precautions, general operating procedures, maintenance instructions and parts breakdown. This machine has been designed and constructed to provide years of trouble free operation if used in accordance with instructions set forth in this manual. If there are any questions or comments, please contact either your local supplier or WMH Tool Group. WMH Tool Group can also be reached at our web site: www.wmhtoolgroup.com.

Specifications

Model Number	OES9138	OES9138
Stock Number	1791282	1791293
Motor	3HP, 1Ph, 230V	3HP, 3Ph, 230/460V (prewired 230)
Electrical Controls	24V magnetic	24V magnetic
Belt Size (in.)	9 x 138-3/4	9 x 138-3/4
Platen Size (in.)	9-1/2 x 48	9-1/2 x 48
Table Working Height (in.)	34-1/2 to 40-3/4	34-1/2 to 40-3/4
Main Table Size (L x W) (in.)	48 x 11-3/4	48 x 11-3/4
Main Table Tilt (deg.)	5 in and 45 out	5 in and 45 out
End Table Size (in.)	18 radius	18 radius
End Table Tilt (deg.)	40 in and 45 out	40 in and 45 out
Belt Speed (FPM)	3,542	3,542
Oscillations per Minute	24	24
Drum Diameter (in.)	4 Outboard, 9 Drive	4 Outboard, 9 Drive
Dust Connection Diameter - Two (in.)	4	4
Dust Collection Minimum CFM Required	1,100	1,100
Overall Dimensions (L x W x H) (in.)	83 x 32 x 50	83 x 32 x 50
Shipping Dimensions (L x W x H) (in.)	86 x 27 x 44-1/2	86 x 27 x 44-1/2
Weight Shipping/Net (lbs.)	870/800	870/800

The above specifications were current at the time this manual was published, but because of our policy of continuous improvement, WMH Tool Group reserves the right to change specifications at any time and without prior notice, without incurring obligations.

Features of the OES9138 Edge Sander

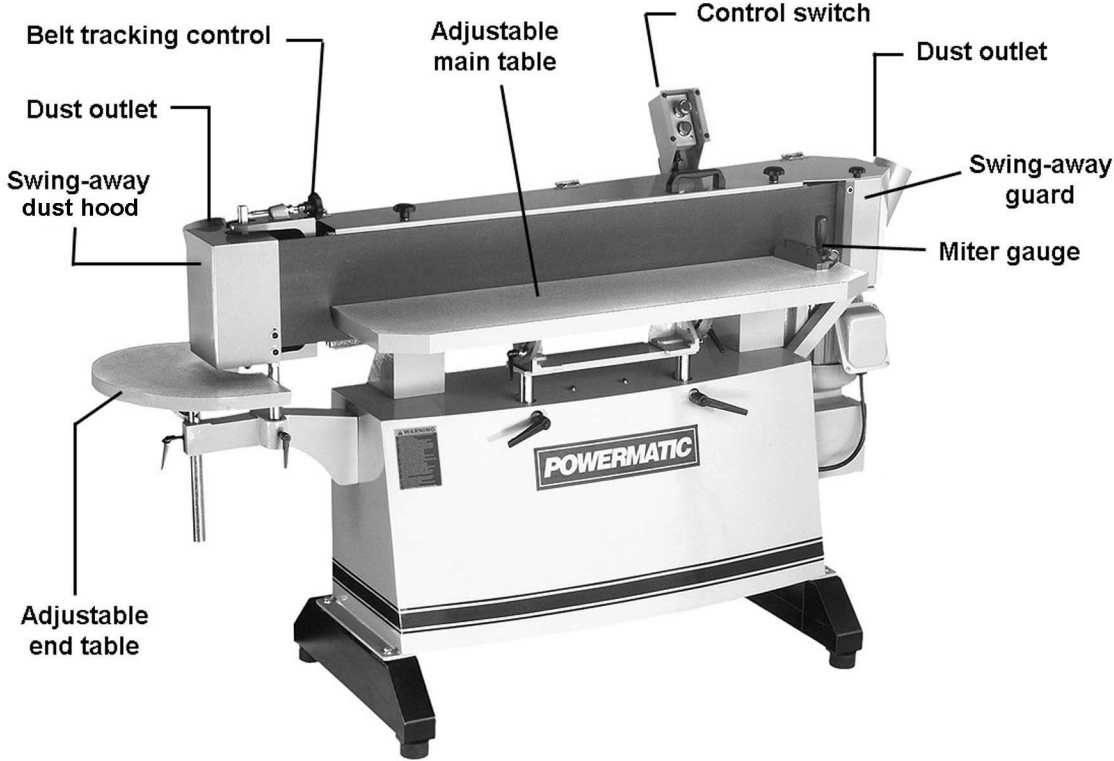

⚠ WARNING

Read and understand the entire contents of this manual before attempting set-up or operation! Failure to comply may cause serious injury.

Unpacking

Open shipping container and check for shipping damage. Report any damage immediately to your distributor and shipping agent. Do not discard any shipping material until the Edge Sander is assembled and running properly.

Compare the contents of your container with the following parts list to make sure all parts are intact. Missing parts, if any, should be reported to your distributor. Read the instruction manual thoroughly for assembly, maintenance and safety instructions.

Contents of the Shipping Container

- 1 Edge Sander
- 2 Mounting Feet
- 4 Rubber Foot Pads
- 1 Control Switch Bracket
- 4 Hex Cap Screws, M10 x 30
- 4 Lock Nuts, M10
- 4 Flat Washers, M10
- 2 Hand Knobs
- 1 Owner's Manual
- 1 Warranty Card

Assembly

Tools required for assembly:

4mm hex wrench
14mm and 17mm wrenches
screwdriver

1. Remove all wood crating from around the sander.
2. Use a 14mm wrench to remove the screws holding the sander to the skid.
3. Lift the machine from the skid with a hoist or forklift by attaching straps to the eyebolts on top the sander. See Figure 1. **DO NOT** fork beneath the main table, or damage to the table may occur.
4. Install two rubber feet onto each cast iron leg. See Figure 2. Screw the feet all the way in so they are all level with one another.
5. Orient the mounting feet beneath the machine so that the double holes are toward the back. See Figure 3. Carefully lower the sander until it touches the mounting feet, and align the four holes.
6. Insert the four M10 x 30 screws, against the four M10 lock washers and M10 flat washers, through the flange on the machine base, and into the threaded holes in the legs. Tighten securely with a 17mm wrench.

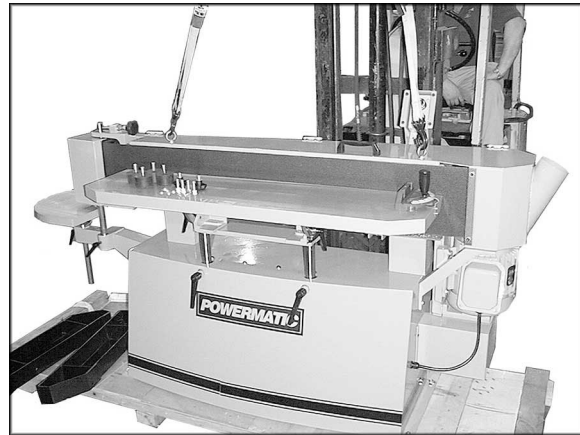

Figure 1



Figure 2

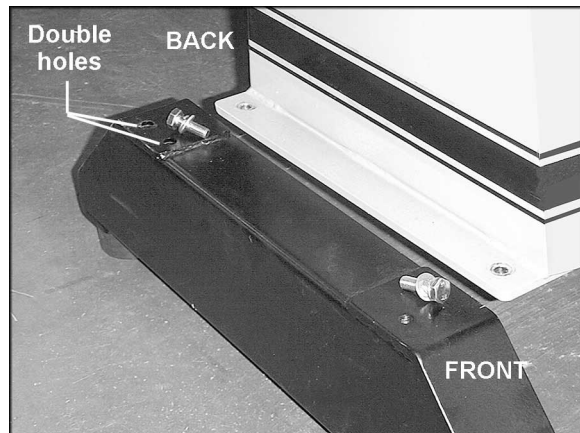

Figure 3

7. The Edge Sander should be located in a dry, well-lighted area, on a solid and level surface, preferably a concrete floor. Leave plenty of space around the machine for operations and routine maintenance work.
8. Exposed metal areas of the Edge Sander have been factory coated with a protectant. This should be removed with a soft cloth dampened with kerosene or mineral spirits. Do not use an abrasive pad. Do not let solvent contact plastic or rubber parts as it may damage them.
9. Unscrew the two eyebolts from the sander and replace them with the hand knobs, shown in Figure 4. Retain the eyebolts for future use. NOTE: After the mounting feet have been installed, the machine can be lifted with a forklift by forking beneath the base.

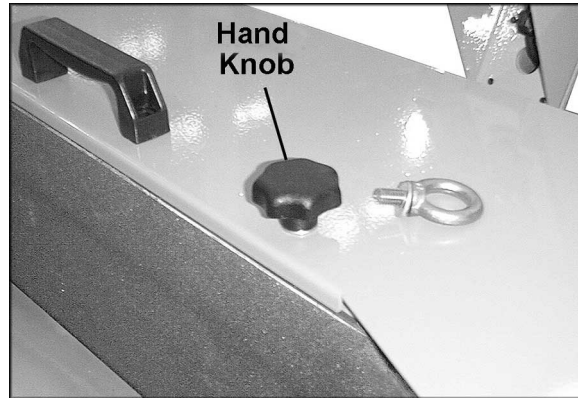

Figure 4

Control Switch Bracket

Mount the control switch bracket (A, Figure 5) to the top of the sander cabinet with a 4mm hex wrench, using the four socket head button screws, lock washers and flat washers (B, Figure 5) that came installed in the threaded holes.

Dust Collection

The use of a dust collection system is strongly recommended for this machine. It will help keep your shop clean as well as minimize any health risks caused by wood dust. Make sure your dust collector has a capacity of at least 1100 cubic feet per minute (CFM).

Connect the intake hoses of your dust collector to the 4" diameter dust chutes on the Edge Sander; there is one on each end of the machine.

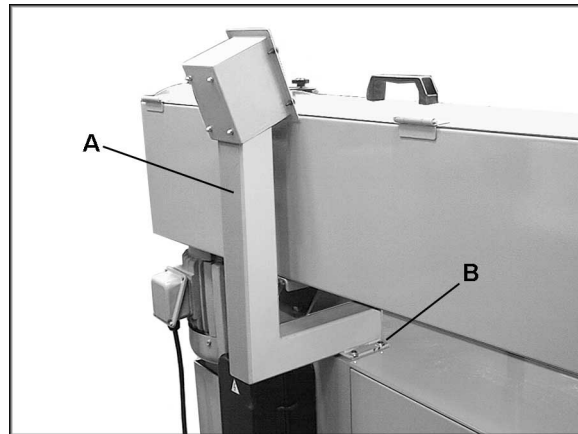

Figure 5

Grounding Instructions

⚠WARNING Electrical connections must be made by a qualified electrician in compliance with all relevant codes. This machine must be properly grounded to help prevent electrical shock and possible fatal injury.

This machine must be grounded. In the event of a malfunction or breakdown, grounding provides a path of least resistance for electric current to reduce the risk of electric shock.

Wire the sander to a grounded, metal-enclosed wiring system in accordance with the requirements of the National Electric Code. Consult the electrical schematics on pages 30 and 31 for clarification.

Improper connection of the equipment-grounding conductor can result in a risk of electric shock. The conductor with insulation having an outer surface that is green with or without yellow stripes, is the equipment-grounding conductor (see Figure 6). If repair or replacement of the electric cord or plug is necessary, do not connect the equipment-grounding conductor to a live terminal.

Check with a qualified electrician or service personnel if the grounding instructions are not completely understood, or if in doubt as to whether the tool is properly grounded. Use only three wire extension cords that have three-prong grounding plugs and three-pole receptacles that accept the tool's plug.

Repair or replace a damaged or worn cord immediately.

Make sure the voltage of your power supply matches the specifications on the motor plate of the Edge Sander.

230 Volt Operation

The Model OES9138 Edge Sander **single phase** unit is designed to run on 230 volt power only.

The **three phase** unit is pre-wired for 230 volt power, but can be converted to 460 volt if so desired (see "Converting to 460 Volt" below).

For 230 volt operation, you may either connect a UL/CSA listed 230V plug (similar to the one shown in Figure 7) or "hard-wire" the machine directly to a control panel. If hard-wired to a panel, make sure a disconnect is available for the operator. The edge sander must comply with all local and national codes after being wired.

1. If it is to be hard-wired, make sure the fuses have been removed or the breakers have been tripped in the circuit to which the Edge Sander will be connected. Place a warning placard on the fuse holder or circuit breaker to prevent it being turned on while the machine is being wired.
2. Refer to "Electrical Connections" on pages 30 and 31, for connecting the motor leads.
3. The Edge Sander with a 230 volt plug should only be connected to an outlet having the same configuration. No adapter is available or should be used with the 230 volt plug.

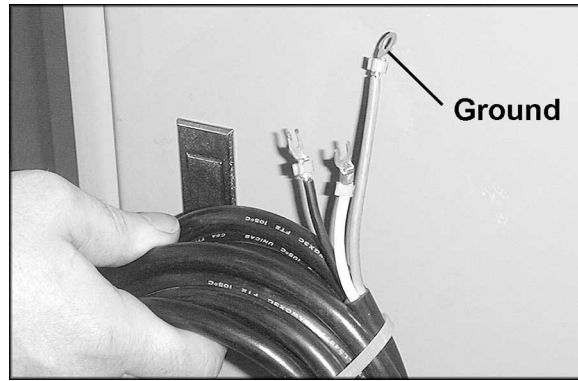

Figure 6
(3-conductor power cable,
single phase machine shown)

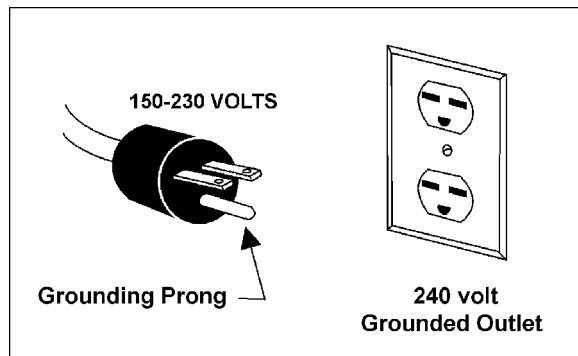

Figure 7

Test Run After Wiring

On the **three-phase** unit, after wiring has been completed, you should check that the wires are connected properly:

1. Connect machine to power source and press the start button (A, Figure 8).
2. The sanding belt should move left to right, as viewed from the front of the machine. If the sanding belt movement is incorrect, press the stop button (B, Figure 8) and disconnect machine from power.
3. Switch any two of the three wires at "R,S,T".
4. Reconnect machine to power source.

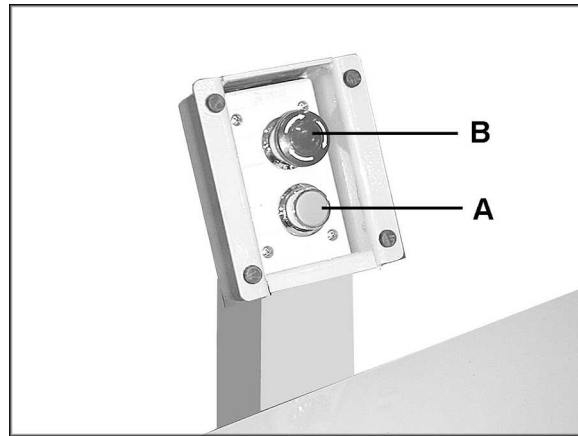

Figure 8

Converting to 460 Volt

Refer to the diagram on page 31 for connecting the motor leads for 460 volt power. If using a plug, it must be a proper UL/CSA listed 460 volt plug. The edge sander must comply with all local and national codes after being wired.

If hard-wiring directly to a control panel, follow the same safety recommendations mentioned under "230 Volt Operation."

Extension cords

An extension cord is not recommended for this machine, but if one is necessary, make sure the cord rating is suitable for the amperage listed on the machine's motor plate. An undersized cord will cause a drop in line voltage resulting in loss of power and overheating.

Use the chart in Figure 9 as a general guide in choosing the correct size cord. If in doubt, use the next heavier gauge. The smaller the gauge number, the heavier the cord.

Recommended Gauges (AWG) of Extension Cords

Amps	Extension Cord Length *					
	25 feet	50 feet	75 feet	100 feet	150 feet	200 feet
< 5	16	16	16	14	12	12
5 to 8	16	16	14	12	10	NR
8 to 12	14	14	12	10	NR	NR
12 to 15	12	12	10	10	NR	NR
15 to 20	10	10	10	NR	NR	NR
21 to 30	10	NR	NR	NR	NR	NR

*based on limiting the line voltage drop to 5V at 150% of the rated amperes.

NR: Not Recommended.

Figure 9

Adjustments

Main Table Positioning

The main table can be raised or lowered to suit your workpiece, and is designed on a special balance mount so that smooth adjustment is achieved by a simple push or pull on the table.

To adjust, loosen the locking handles (A, Figure 10) and move the table to desired position by hand, then tighten locking handles (A, Figure 10).

CAUTION If the table is in low position, it may spring up suddenly when the locking handles are loosened.



Figure 10

Main Table Tilting

The main table can be tilted up to 5° in and 45° out, to match the angle of your workpiece.

1. Loosen the locking handle (B, Figure 11) on both sides beneath the table.
2. With the workpiece on the table, swivel the table into the desired position with the workpiece, or use the indicator scale (C, Figure 11).
3. Tighten locking handles (B, Figure 11).

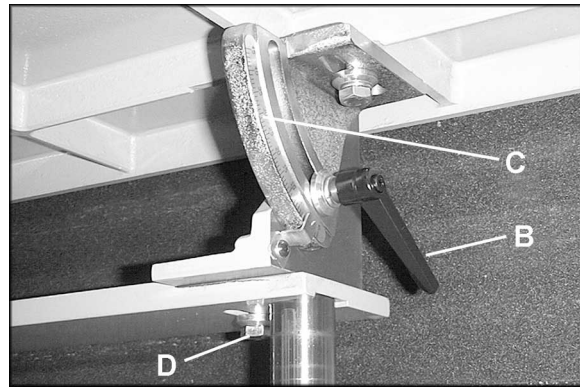

Figure 11

Table/Belt Clearance

The amount of clearance between the main table and the sanding belt can be adjusted. Loosen the screws (D, Figure 11) and slide the table forward or backward. Re-tighten screws (D, Figure 11).

Miter Gauge

To adjust the miter gauge, loosen the handle (A, Figure 12). Rotate the miter gauge body until the desired angle on the scale lines up with the notch in the pointer (B, Figure 12). Tighten the handle (A, Figure 12).

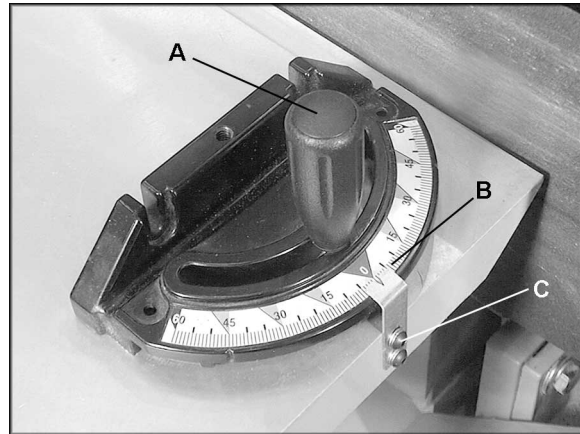

Figure 12

To remove the miter gauge from the table:

1. Unscrew and remove the handle (A, Figure 12).
2. Remove the socket head button screws, flat washers and lock washers (C, Figure 12) with a hex wrench, and remove the pointer.
3. On the underside of the table, use a screwdriver to remove the screw (not shown) that holds the miter gauge body to the table.

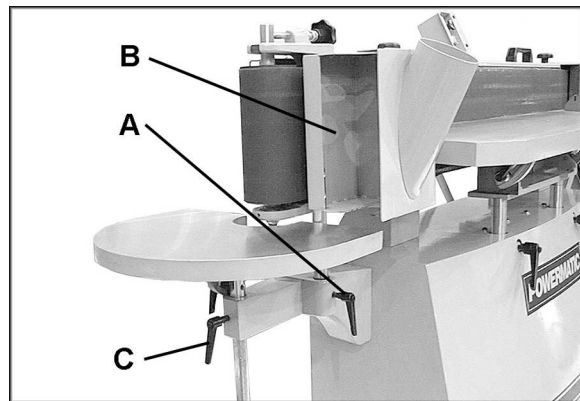

Figure 13

End Table

The end table allows contour sanding. Loosen the locking handle (A, Figure 13) and swing the dust hood (B, Figure 13) away from the belt as shown. In some cases the dust hood may have to be removed entirely.

CAUTION If the sanding procedure requires removal of the dust hood, be sure to re-install dust hood when finished with that procedure.

Loosen locking handle (C, Figure 13) to raise or lower the end table. Tighten locking handle after adjustment.

Loosen locking handle (D, Figure 14) to tilt the end table. Tighten locking handle after adjustment.

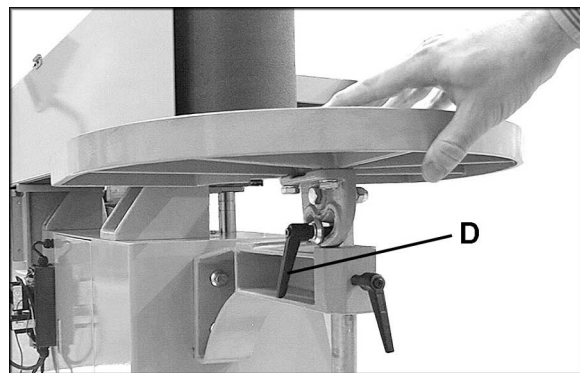

Figure 14

End Guard

The end guard (A, Figure 15) on the right side of the machine can be swung out of the way for sanding long workpieces. (The miter gauge will need to be removed for such a procedure.)

Loosen the hand knob (B, Figure 15) and swing open the end guard all the way until it catches the latch behind it. When finished with the operation, close the end guard and tighten the hand knob.

Replacing Sanding Belt

1. Disconnect machine from power source.
2. Swing the end guard (Figure 15) out of the way, then open the belt guard (C, Figure 16). Also swing the dust hood out of the way (see Figure 13).
3. Release tension on the belt by pulling the tension lever (D, Figure 16) all the way up until it stops against the screw head.
4. Remove the old sanding belt and replace with the new one.

NOTE: Identify the sanding belt direction before you install the belt, because the belt's rotational direction must be the same as the machine. An arrow on the reverse side of the belt shows the proper direction. The belt will move left to right as viewed from the front of the machine. If the belt has no arrow indicator, find the joint of the belt (where it is layered) and install it according to Figure 17.

5. Tension the belt by pushing the lever (A, Figure 16) all the way down.
6. The sanding belt should now be checked for tracking. See "Tracking Adjustment."

Tracking Adjustment

"Tracking" refers to the position of the sanding belt on the drums while the sanding belt is in motion. For proper operation, the sanding belt should be centered upon the drive drum.

If a new sanding belt has just been installed, the initial tracking adjustment should be done with the machine OFF. Rotate the drums by hand and adjust the tracking mechanism as needed (see below).

After operating the machine, further minute adjustments may be needed to the tracking. This can be done with the machine turned ON and the sanding belt in motion. Turning the tracking adjustment knob (B, Figure 18) should always be done gradually and in small increments.

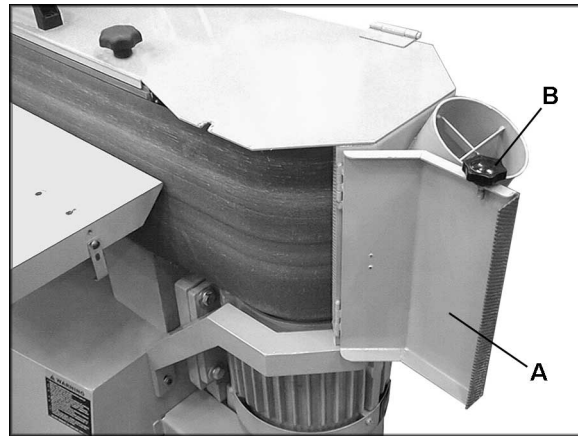

Figure 15

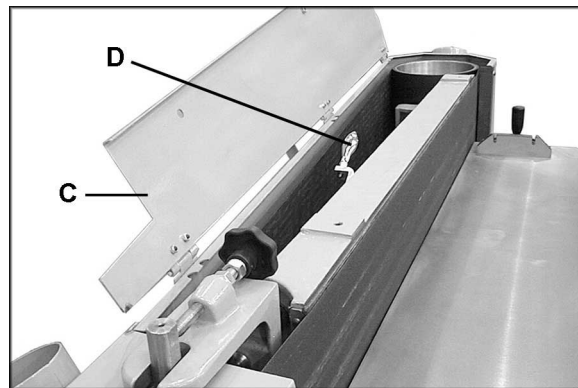

Figure 16

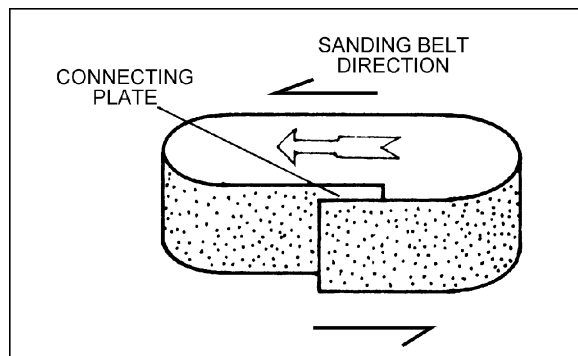

Figure 17

To adjust tracking, proceed as follows:

1. Loosen the nut (A, Figure 18).
2. Turn the adjustment knob (B, Figure 18) counter-clockwise to shift the belt upward; clockwise to shift the belt downward.
3. When the belt is centered and tracking properly, tighten nut (A, Figure 18).
4. After adjustments are complete, close all guards.

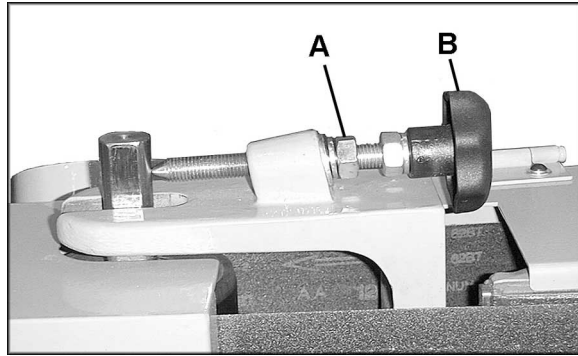

Figure 18

Operating Controls

Press the start switch (A, Figure 19) to activate the sanding belt. The stop button (B, Figure 19) is a mushroom style button which is convenient for "emergency" shut-downs during operation, if such should ever be necessary. When re-starting the sander, twist the knurled ring of the stop button clockwise to release it.

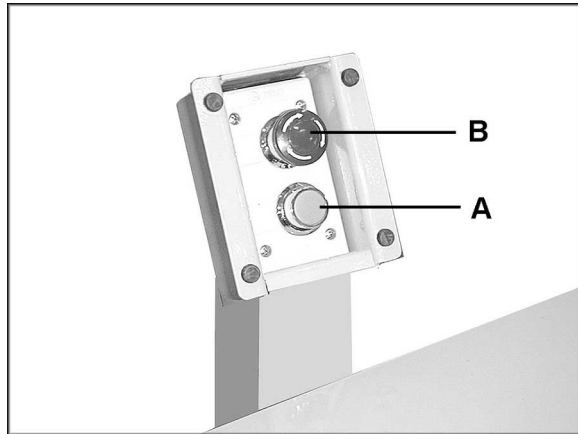

Figure 19

Operation

Your oscillating belt Edge Sander is designed and manufactured for long-term operation creating superior sanded surfaces for wood products. The oscillation of the belt helps prevent sanding marks in the workpiece, and allows longer belt wear.

Before operating the Edge Sander, make sure all locking handles and knobs are tight on guards and tables.

Always use the miter gauge, when possible, to support your workpiece.

CAUTION This machine is suited for sanding wood products only. Do not use this machine for sanding metal products.

Maintenance

⚠WARNING Before doing maintenance on the machine, disconnect it from the electrical supply. Failure to comply may cause serious injury.

Periodically check both drums. The drums are made of rubber material and may experience wear after a long period of use, at which time they should be replaced.

The sander should be cleaned frequently.

Check all screws, hex nuts, and other fasteners to make sure they are tight.

Check condition of sanding belt. If belt is worn, replace it.

If the power cord is worn, cut, or damaged in any way, have it replaced immediately.

The table should be kept clean and free of rust. If rust appears on the table, use 000 steel wool with a paste mixture of household ammonia and good commercial detergent (or use a commercial rust remover available from most hardware and tool supply stores).

Some users coat their table surface with a light coat of paste wax. (Do not get paste wax on the sanding belt.) Another option is to apply talcum powder to the table surface and rub it in briskly with a clean blackboard eraser. This will also maintain a slick surface, and will not stain wood.

Lubrication

All ball bearings are sealed for life and do not require further lubrication.

Troubleshooting the OES9138 Edge Sander

Trouble	Probable Cause	Remedy
Machine will not start/restart or repeatedly trips circuit breakers or blows fuses.	Machine not connected to power source.	Verify machine is connected to power.
	Fuse blown, or circuit breaker tripped.	Replace fuse, or reset circuit breaker.
	Cord damaged.	Replace cord.
	Extension cord too light or too long.	Use adequate size extension cord.
	Overload automatic reset has not reset.	If the Edge Sander overloads on the circuit breaker built in to the motor starter, it takes time for the machine to cool down before restart. Allow unit to adequately cool before attempting restart. If problem persists, check amp setting on the motor starter inside the electrical box.
	Edge Sander frequently trips.	Check the amp setting on the overload relay. Match the full load amps on the motor as noted on the motor plate. If amp setting is correct then there is probably a loose electrical lead or a failed component. See below.
	Building circuit breaker trips or fuse blows.	Verify that edge sander is on a circuit of correct size. If circuit size is correct, there is probably a loose electrical lead. Check amp setting on motor starter.
	Loose electrical connections.	Go through all the electrical connections on the edge sander including motor connections, verifying the tightness of each. Look for any signs of electrical arcing which is a sure indicator of loose connection or circuit overload.
	Motor starter failure.	If you have access to a voltmeter, you can separate a starter failure from a motor failure by first, verifying incoming voltage at 220+/-20 and second, checking the voltage between starter and motor at 220+/-20. If incoming voltage is incorrect, you have a power supply problem. If voltage between starter and motor is incorrect, you have a starter problem. If voltage between starter and motor is correct, you have a motor problem.
Motor failure.	If electric motor is suspect, you have two options: Have a qualified electrician test the motor for function or remove the motor and take it to a qualified electric motor repair shop and have it tested.	

Trouble	Probable Cause	Remedy
Machine will not start/restart or repeatedly trips circuit breakers or blows fuses.	Miswiring of the unit.	Check to make certain all electrical connections are correct and properly tight. The electrical connections other than the motor are preassembled and tested at the factory. Therefore, the motor connections should be checked as the highest probability for error. If problems persist, double check the factory wiring.
	On/off switch failure.	If the on/off switch is suspect, you have two options: Have a qualified electrician test the switch for function, or purchase a new on/off switch and establish if that was the problem on changeout.
Sanding belt won't come up to speed.	Extension cord too light or too long.	Use adequate size extension cord.
	Low (incoming) voltage.	Contact qualified electrician.
	Excessive bite, or feed pressure too great.	Allow sanding belt to cut freely, do not force.
Belt won't track.	Drum is worn.	Replace drum.
	Belt is stretched unevenly.	Replace belt.
Belt slips or stalls on application of pressure.	Sanding belt tension not adequate.	Make sure lever is down all the way (page 13).
Excessive sanding belt replacement.	Too much pressure being used during cuts.	Reduce pressure.
	Not using full width of belt.	Stroke across the belt using full width.
Machine vibrates excessively.	Improper motor mounting.	Check and adjust mounting.
	Spring on tension mechanism is fatigued or broken.	Replace with new spring.
	Drum is loose.	Tighten cap screw in motor (page 23, #39).
	Bad or broken sanding belt.	Replace sanding belt.
Sanding marks on workpiece.	Sanding belt too coarse for required finish.	Use proper grit. Coarser grits for stock removal, and finer grits for finish work.
	Workpiece sanded across grain.	When surface sanding, use very fine sanding belt then finish by hand, working in direction of grain.
Sanding grains quickly rub off belt.	Sanding belt has lost its original properties.	Do not store sanding belts in extremely dry or high-temperature areas. Do not fold sanding belts.
Sanding belt becomes glazed.	Sanding painted surface.	Use open-end grain/flint belt.
	Wood is wet or gummy.	No cure. Use different stock.

Trouble	Probable Cause	Remedy
Work burns.	Wrong sanding belt surface.	Use coarser grit for stock removal.
	Feed pressure too great.	Never force workpiece into steel platen. Use just enough pressure, and let the sanding belt do the work.
Sanding belt burns, or clogs quickly on thickness sanding.	Biting too deep.	Adjust for slight sanding action and make repeated passes.
Workpiece pulled from hand.	No support for workpiece.	Use miter gauge on table.
Sanding belt has broken at the joint.	Belt running in wrong direction.	Orient direction of arrows printed on sanding belt to match rotation of drums. Sanding belt should move left to right as viewed from front of machine.
Sanded edge is not square.	Result of freehand sanding.	Keep workpiece flat on table at all times when a square edge is desired. Use miter gauge.
	Table misaligned.	Check table alignment to steel platen with a square or machinist's protractor. It should be 90 degrees. Adjust table angle if necessary (page 12).

Optional Accessories

6078029 Sanding Belt, 60 Grit, 9" x 138-3/4"
6078030 Sanding Belt, 80 Grit, 9" x 138-3/4"
6078031 Sanding Belt, 100 Grit, 9" x 138-3/4"
6078032 Sanding Belt, 120 Grit, 9" x 138-3/4"
6078033 Sanding Belt, 150 Grit, 9" x 138-3/4"
6078034 Sanding Belt, 180 Grit, 9" x 138-3/4"
6078035 Sanding Belt, 220 Grit, 9" x 138-3/4"

Replacement Parts

Replacement parts are listed on the following pages. To order parts or reach our service department, call 1-800-274-6848 between 7:00 a.m. and 6:00 p.m. (CST), Monday through Friday. Having the Model Number and Serial Number of your machine available when you call will allow us to serve you quickly and accurately.

Parts List: Base Assembly

Index No.	Part No.	Description	Size	Qty
1	OES-001	Machine Base		1
2	OES-002	Magnetic Motor Starter	1Ph, 230V	1
	OES-093	Magnetic Motor Starter	3Ph, 230/460V	1
3	OES-003	Oscillating Unit Cover		1
4	TS-2246082	Socket Head Button Screw	M6 x 8	4
5	OES-004	Support Bracket		1
6	TS-1550041	Flat Washer	M6	15
7	TS-1551041	Lock Washer	M6	13
8	TS-2246162	Socket Head Button Screw	M6 x 16	13
9	OES-005	Mounting Foot		2
10	TS-1550071	Flat Washer	M10	8
11	TS-1551071	Lock Washer	M10	8
12	TS-1491041	Hex Cap Screw	M10 x 30	4
13	OES-006	Rubber Foot Pad		4
14	OES-007	Platen Casting		1
17	TS-2210451	Hex Cap Screw	M10 x 45	4
18		Sanding Belt (also see Optional Accessories, page 19)		1
19	OES-008	Graphite Pad		1
20	OES-009	Pad Retaining Plate		2
21	TS-1551031	Lock Washer	M5	6
22	TS-2245162	Socket Head Button Screw	M5 x 16	6
23	OES-010	Lt. Sanding Guard Bracket		1
27	OES-011	Rt. Sanding Guard Bracket		1
29	OES-012	Belt Guard		1
33	OES-013	Guard Plate		1
36	OES-014	"U" Handle		1
37	TS-1504031	Socket Head Cap Screw	M8 x 16	2
38	TS-1541031	Nylon Lock Hex Nut	M8	2
39	OES-015	Hand Knob		2
40	OES-016	Lifting Eyebolt		2
41	OES-017	Switch Arm		1
45	OES-018	Rubber Pad		4
46	OES-019	Start/Stop Switch		1
47	OES-094	Clipper (Female)		1
48	OES-095	Clipper (Male)		1
49	TS-2283061	Phillips Flat Head Machine Screw	M3 x 6	4
50	OES-096	Hand Knob	1/4"	1

Parts List: Drive Unit

Index No.	Part No.	Description	Size	Qty
1	OES-020	Ball Bearing Assembly		2
2	TS-2360121	Flat Washer	M12	4
3	TS-1551081	Lock Washer	M12	6
4	TS-1492041	Hex Cap Screw	M12 x 40	4
5	OES-021	Pivot Shaft		1
6	OES-022	Motor Base		1
7	TS-1525011	Socket Set Screw	M10 x 10	2
8	OES-023A	Motor	3HP, 1Ph, 230V	1
	OES-087A	Motor	3HP, 3Ph, 230/460V	1
9	TS-1550071	Flat Washer	M10	4
10	TS-1551071	Lock Washer	M10	6
11	TS-1492031	Hex Cap Screw	M12 x 35	4
12	OES-024A	Oscillating Motor Bracket		1
13	TS-1551061	Lock Washer	M8	5
14	TS-1504051	Socket Head Cap Screw	M8 x 25	2
15	TS-1504041	Socket Head Cap Screw	M8 x 20	4
16	OES-025B	Oscillating Unit (includes circled items on breakdown)		1
17	OES-026B	Reducer Box		1
18	OES-027	Bracket		1
19	TS-1550061	Flat Washer	M8	2
21	TS-2248162	Socket Head Button Screw	M8 x 16	2
22	OES-028	Bearing Housing		1
23	OES-029	Bearing	6001	1
24	OES-030	Spherical Bearing	PB-10	1
26	TS-149105	Hex Cap Screw	M10 x 35	1
28	TS-2331101	Cap Nut	M10	1
30	TS-1492021	Hex Cap Screw	M12 x 30	1
31	OES-031	Cam		1
32	OES-032	Shaft Key	M6 x 30	1
33	OES-033	Flat Washer	8 x 22 x 5	1
35	TS-2248202	Socket Head Button Screw	M8 x 20	1
36	OES-034	Drive Drum		1
37	OES-035	Washer	12 x 40 x 4	1
39	TS-1492011	Hex Cap Screw	M12 x 25	1
40	OES-088	Power Cord (not shown)	1Ph	1
	OES-089	Power Cord (not shown)	3Ph	1
41	OES-090	Motor Cord (not shown)	1Ph	1
	OES-091	Motor Cord (not shown)	3Ph	1
42	OES-092	Switch Cord (not shown)		1
43	OES-023SC	Capacitor, Start (not shown)		1
44	OES-023RC	Capacitor, Run (not shown)		1

Drive Unit

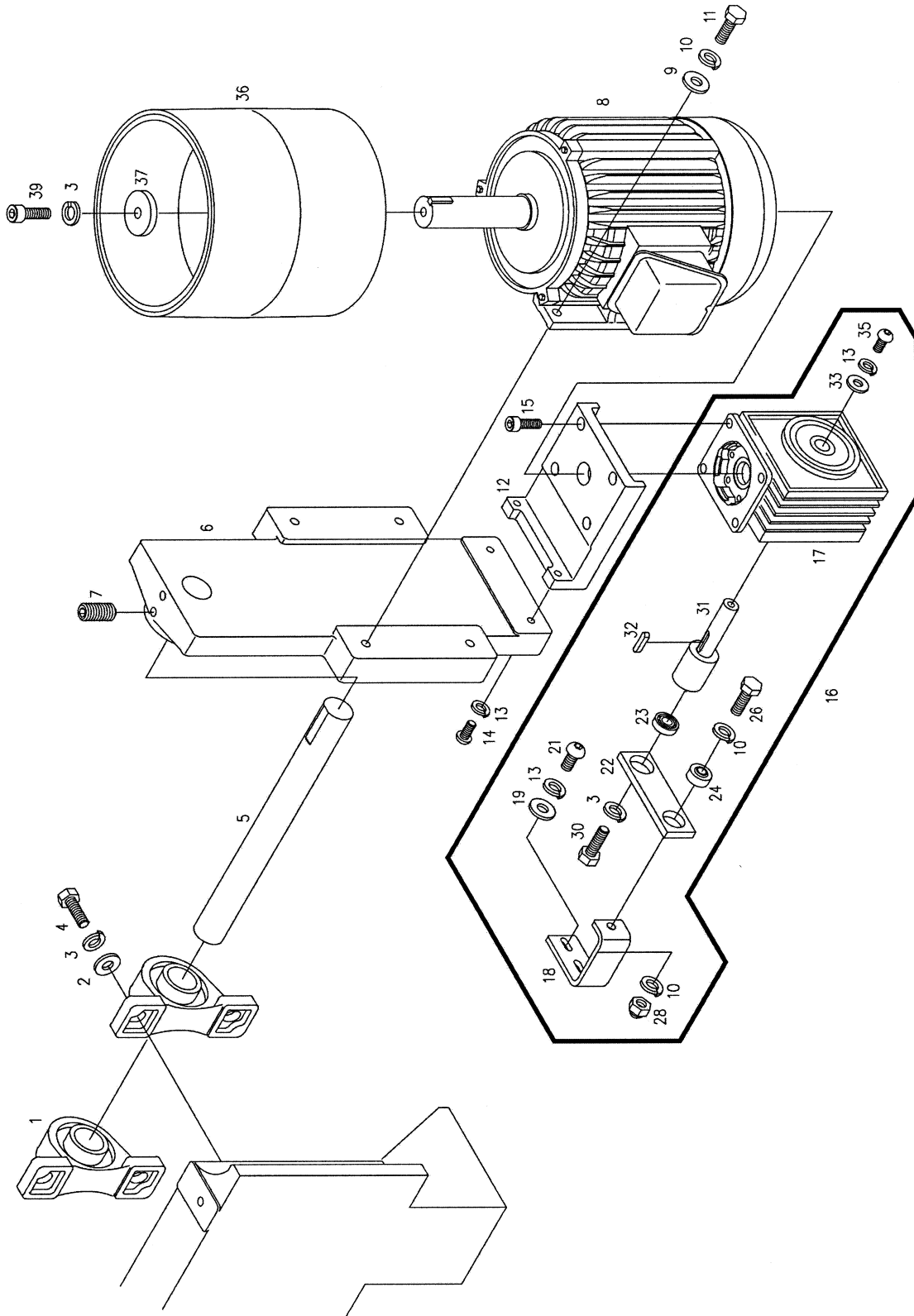

Parts List: Tracking and Belt Release Unit

Index No.	Part No.	Description	Size	Qty
1	OES-036	Belt Release Post		2
2	OES-037	Bushing		4
3	OES-038	Stop Collar		2
4	OES-039	Spring		2
5	OES-040	Lever Plate		1
6	TS-1551071	Lock Washer	M10	6
7	TS-1491041	Hex Cap Screw	M10 x 30	3
8	TS-1525011	Socket Set Screw	M10 x 10	4
9	OES-041	Lever Arm		1
10	OES-042	Lever Handle		1
11	TS-1506031	Socket Head Cap Screw	M12 x 30	1
12	TS-1551081	Lock Washer	M12	3
13	TS-2331121	Cap Nut	M12	1
14	TS-149105	Hex Cap Screw	M10 x 35	1
16	OES-043	Bushing		1
17	OES-044	Bearing		1
18	TS-1550071	Flat Washer	M10	3
19	TS-2331101	Cap Nut	M10	1
20	OES-045	Idler Adjustment Unit		1
21	OES-046	Idler Casting		1
22	OES-047	Spherical Bearing		1
25	TS-2249162	Socket Head Button Screw	M10 x 16	1
26	OES-048	Washer	10 x 25 x 6	2
28	TS-2249252	Socket Head Button Screw	M10 x 25	2
30	TS-1540081	Hex Nut	M12	2
31	OES-049	Tracking Screw		1
32	TS-2360121	Flat Washer	M12	1
33	OES-050	Tracking Adjust Knob		1
34	OES-051	Idler Wheel Unit		1
35	OES-052	Idler Shaft		1
36	OES-053	Bearing	6205	2
37	OES-054	Tracking Roller		1
38	OES-055	Retaining Ring		1

Tracking and Belt Release Unit

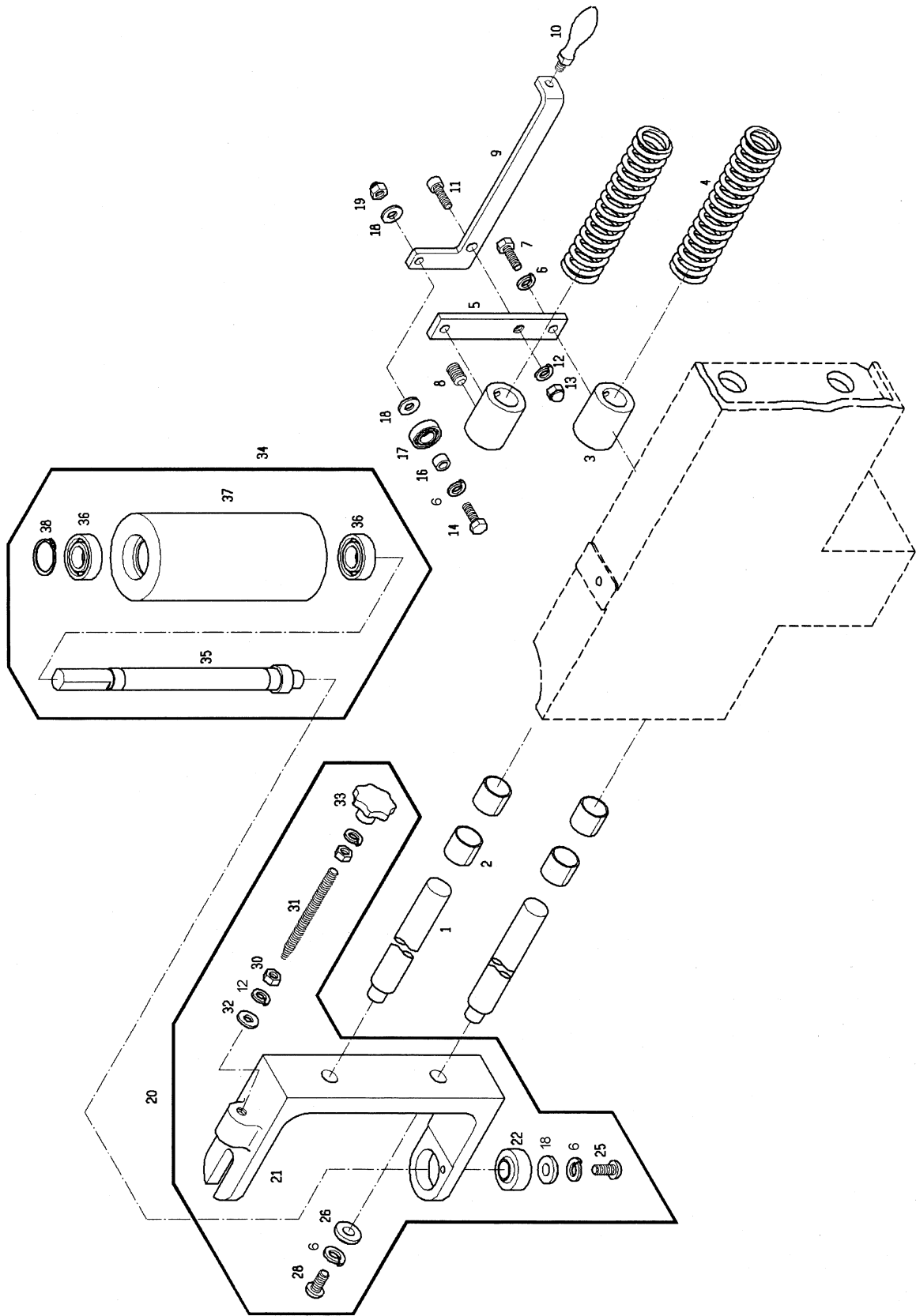

Parts List: Table Assembly

Index No.	Part No.	Description	Size	Qty
1	OES-056	Elevation Casting		1
2	OES-057	DU Bushing	3025	4
3	OES-058	Seal	35 x 50 x 8	4
4	OES-059	Table Post		2
5	OES-060	Link		1
6	TS-1490051	Hex Cap Screw	M8 x 30	2
7	OES-061	Spring		2
8	TS-1550061	Flat Washer	M8	6
9	TS-1551061	Lock Washer	M8	6
10	TS-1490011	Hex Cap Screw	M8 x 12	2
11	TS-1491081	Hex Cap Screw	M10 x 50	2
12	TS-1540071	Full Hex Nut	M10	2
13	TS-1551071	Lock Washer	M10	10
14	TS-2248252	Socket Head Button Screw	M8 x 25	4
17	OES-062	Locking Handle		2
18	OES-063	Adjustment Plate		1
19	TS-1516021	Socket Head Flat Screw	M10 x 25	2
20	OES-064	Flat Washer	10 x 25 x 6	4
22	TS-1491041	Hex Cap Screw	M10 x 30	4
23	OES-065	Table Bracket Rt.		1
24	OES-066	Tilt Bracket Rt.		1
27	TS-2331101	Cap Nut	M10	2
30	OES-067	Locking Handle		2
31	OES-068	Angle Scale		1
32	OES-069	Angle Pointer		1
33	TS-1550031	Flat Washer	M5	3
34	TS-1551031	Lock Washer	M5	3
35	TS-2245102	Socket Head Button Screw	M5 x 10	3
36	OES-070	Table Bracket Lt.		1
37	OES-071	Tilt Bracket Lt.		1
38	OES-072	Main Table		1
39	OES-073	Washer	10 x 25 x 6	2
41	TS-149105	Hex Cap Screw	M10 x 35	2
42	OES-074	Mitre Gauge & Dowel Screw		1
43	OES-075	Lock Handle		1
44	OES-076	Mitre Gauge Pointer		1

Table Assembly

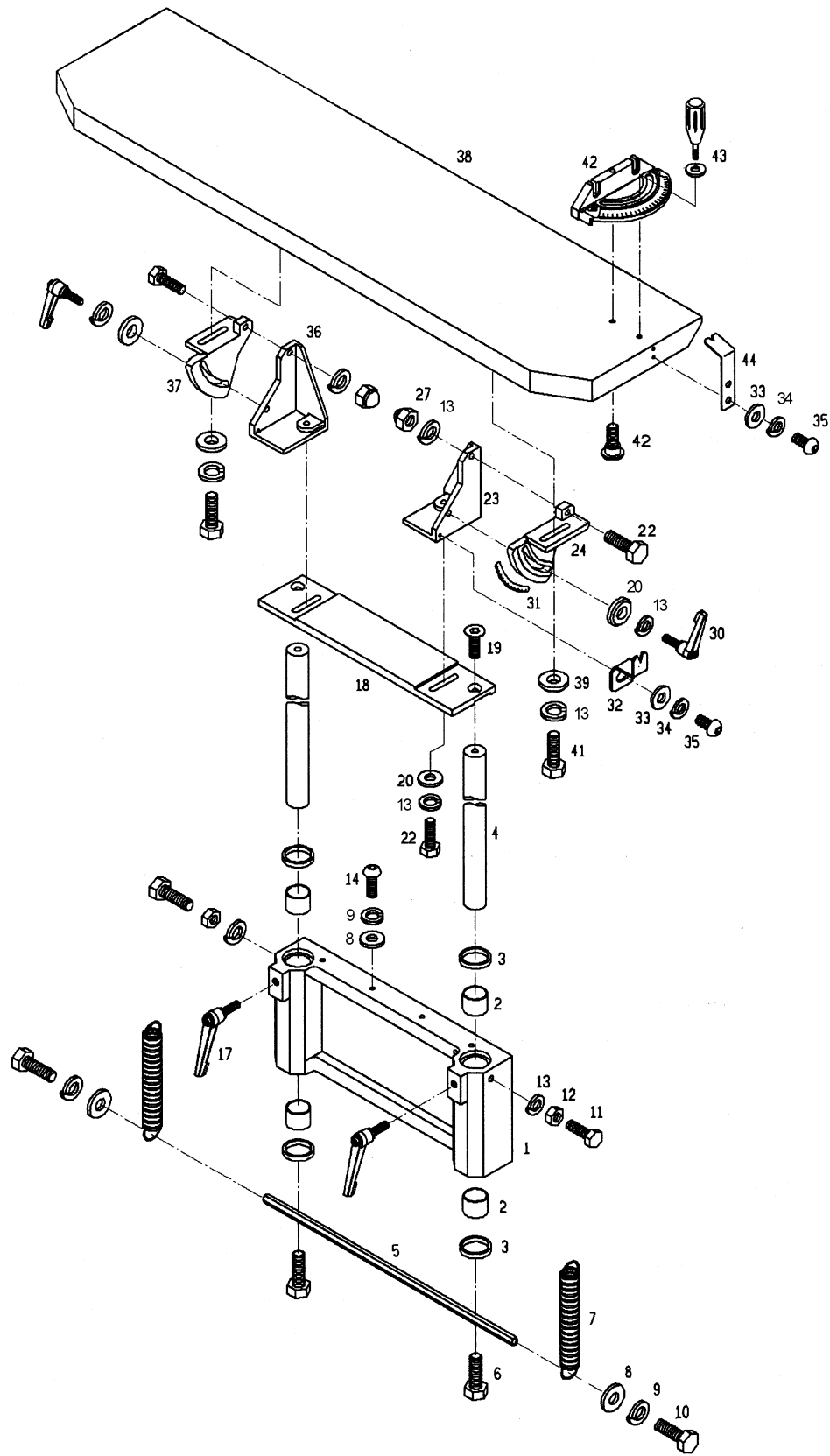

Parts List: Contour Sanding Unit

Index No.	Part No.	Description	Size	Qty
1	OES-077	Sanding Arm Casting		1
2	TS-1550071	Flat Washer	M10	4
3	TS-1551071	Lock Washer	M10	6
4	TS-1491061	Hex Cap Screw	M10 x 40	2
5	OES-078	Locking Handle		2
6	OES-079	Table Post		1
7	OES-080	Contour Table Unit		1
8	TS-1491081	Hex Cap Screw	M10 x 50	1
10	TS-2331101	Cap Nut	M10	1
11	OES-081	Washer	10 x 25 x 6	1
13	OES-067	Locking Handle	M10 x 35	1
16	TS-1491031	Hex Cap Screw	M10 x 25	2
17	OES-082	Tilt Bracket		1
18	OES-083	Contour Sanding Table		1
19	OES-084	Retaining Ring		1
20	OES-085	Guard Post		1
21	OES-086	Dust Hood		1
22	TS-1550061	Flat Washer	M8	2
23	TS-1551061	Lock Washer	M8	2
24	TS-2248162	Socket Hd Button Screw	M8 x 16	2

Contour Sanding Unit

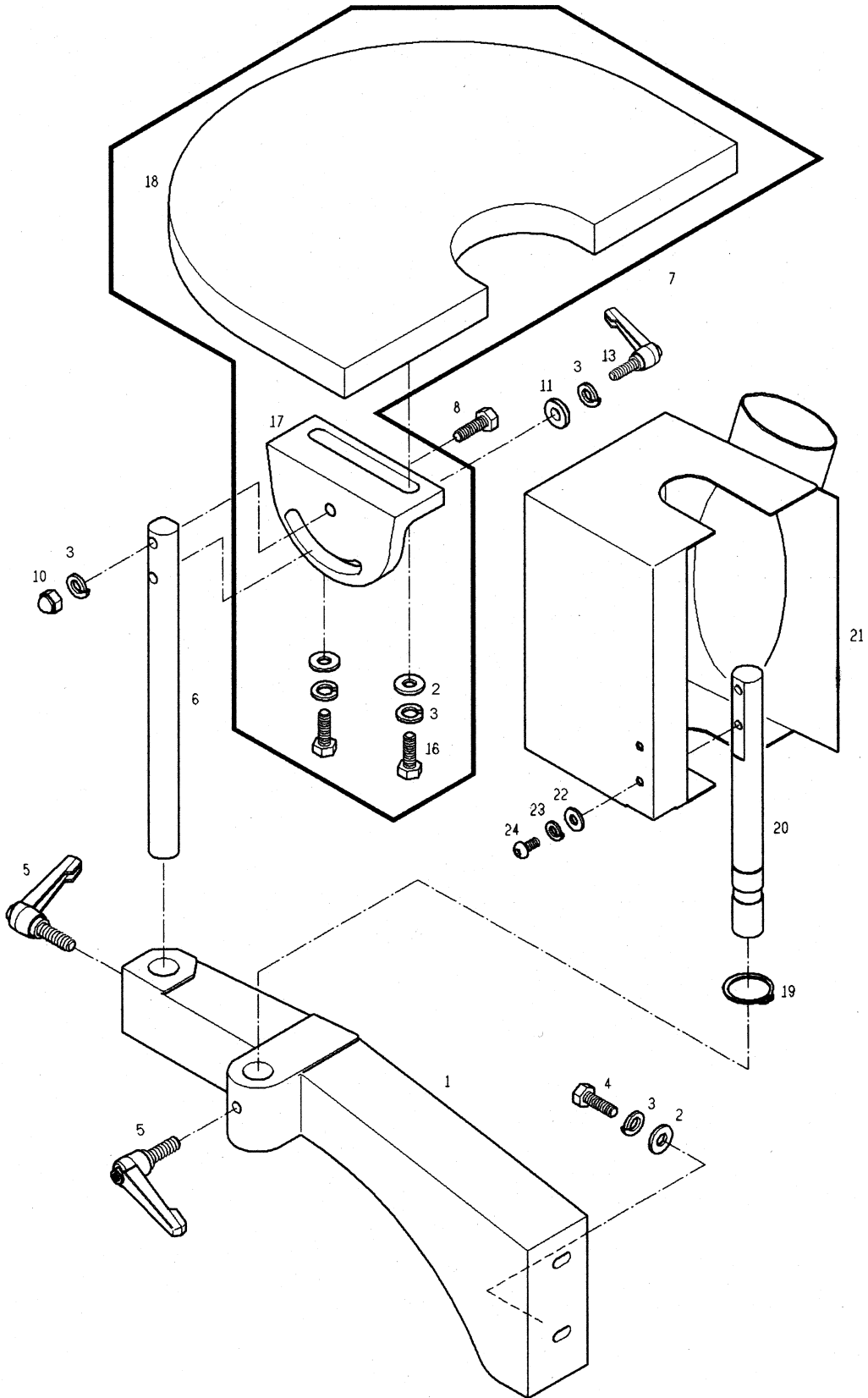

Electrical Connections – 1 Phase

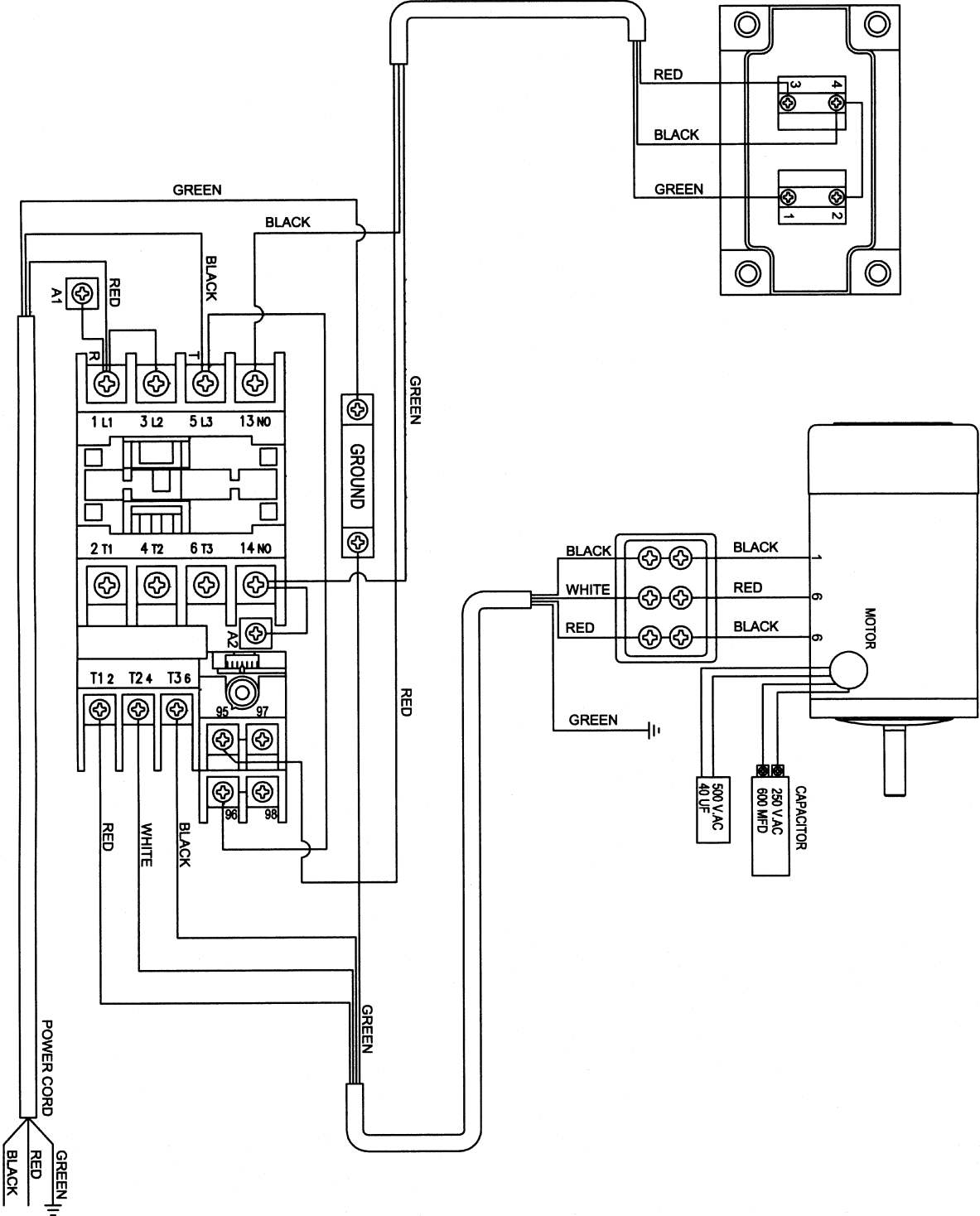

Electrical Connections – 3 Phase

Place fuse in appropriate slot for desired voltage.
Pre-set 230V at factory.

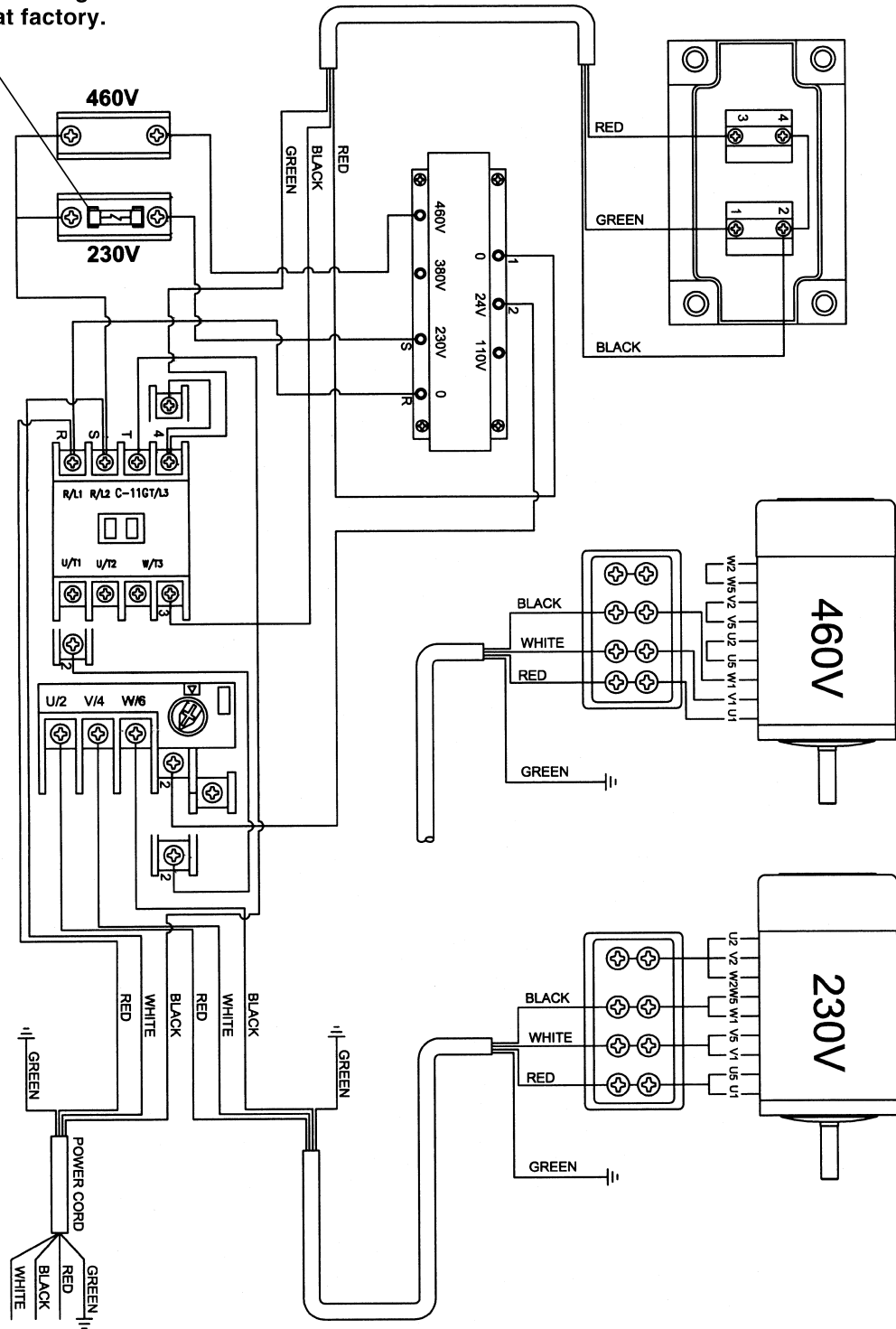

POWERMATIC[®]

WMH Tool Group
2420 Vantage Drive
Elgin, Illinois 60123
Phone: 800-274-6848
www.wmhtoolgroup.com