

14RT Series

Model 14RT400A

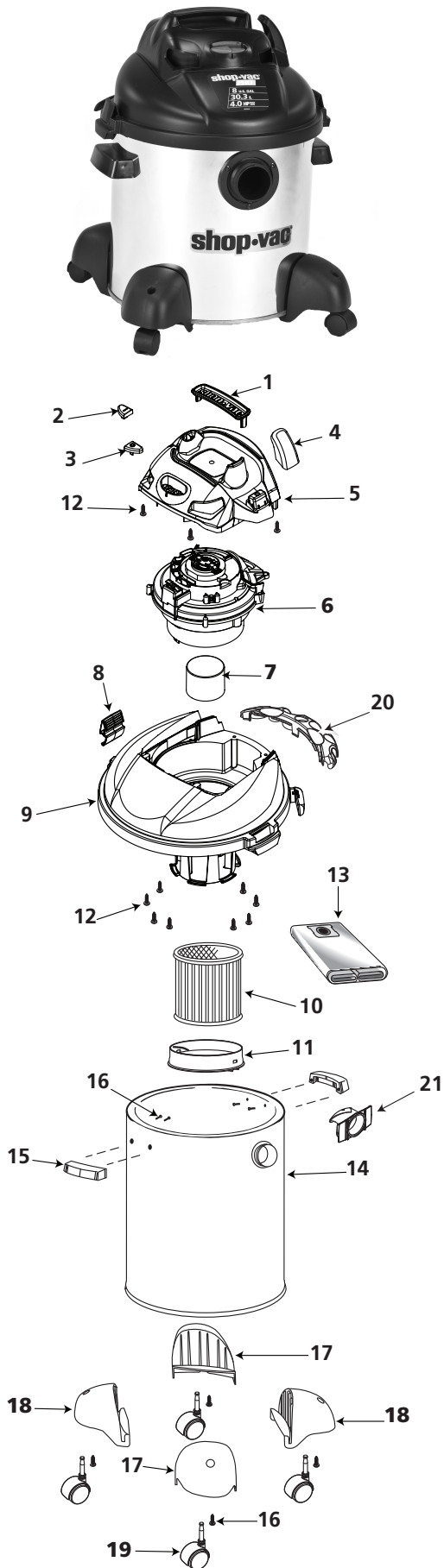

ITEM	DESCRIPTION	PART NO.
1	Handle	3751031
2	Switch Button - I	7414200
3	Switch Button - O	7414210
4	Cord Hook	3856430
5	Motor Cover Assembly	2432021
6	Power Unit Assembly	8120597
7	Float	3545000
8	Lid Latch	7441601
9	Lid Cage and Latch Assembly	1944704
10	Cartridge Filter	90304
11	Filter Retainer	3008000
12	Screw Hex Head #10 x 3/4 Trilobe, Twin Lead	1517699
13	Collection Filter Bag	90661
14	Tank Assembly	1944717
15	Side Tank Handle	9355100
16	#10 x 3/4" Screw Hex Head	1503999
17	Caster foot A	8568101
18	Caster foot B	8568111
19	Caster	6774200
20	Tool Holder	8412000
21	Inlet Deflector	7413100

* Replacement parts may differ from original equipment.

THREE-YEAR HOME USE WARRANTY

Your Shop-Vac® vacuum cleaner is warranted in normal household use, in accordance with the User Manual, against original defects in material and workmanship for a period of three years from date of purchase. Should this product be used for commercial or rental use, a 90 day limited warranty will apply. Shop-Vac Corporation warrants placing this vacuum cleaner in correct operating condition, by repair or parts replacement, during the warranty period, without charge. This warranty does not cover accessories. Use of non-recommended filters and/or accessories may void the manufacturer's warranty. For product service contact Shop-Vac Corporation, Customer Service, at (570) 326-3557 or go to www.shopvac.com/support. Shop-Vac® assumes no responsibility for damage or faulty performance caused by misuse or careless handling, or where repairs or modifications have been made or attempted by others. Proof of purchase date is required. This warranty gives you specific legal rights, and you may also have other rights, which vary from state to state. This warranty is void outside of the United States.