

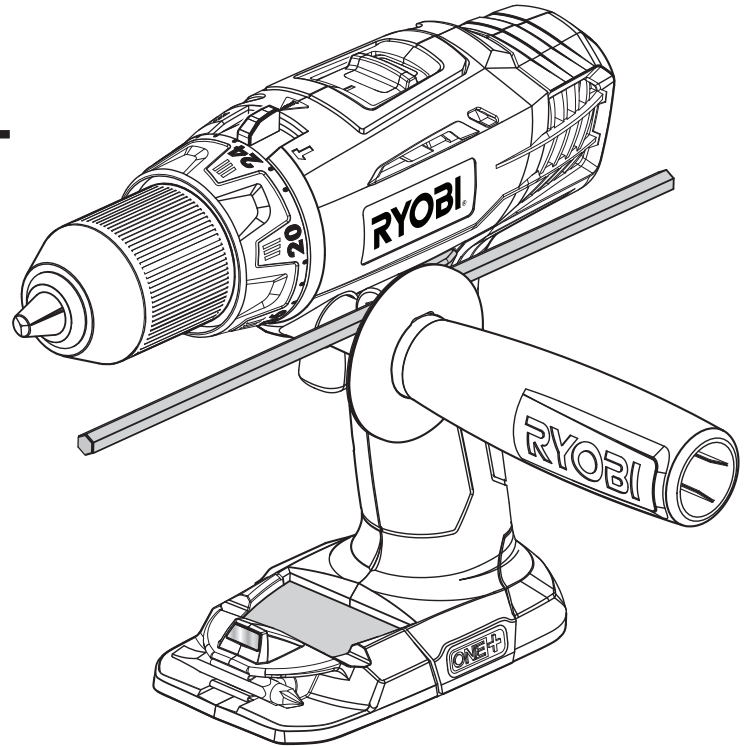

OPERATOR'S MANUAL MANUEL D'UTILISATION MANUAL DEL OPERADOR

18 VOLT HAMMER DRILL PERCEUSE À PERCUSSION DE 18 V TALADRO DE PERCUSIÓN DE 18 V P214



INCLUDES: Hammer Drill, Auxiliary Handle Assembly, **Depth Stop Rod**, Operator's Manual

INCLUT: Perceuses à percussion, poignée auxiliaire, **tige de butée de profondeur**, manuel del utilisation

INCLUYE: Taladros de impacto, mango auxiliar, **barra limitadora de profundidad**, manual del operador

TABLE OF CONTENTS

- General Power Tool Safety Warnings2-3
- Drill-Driver Safety Warnings3
- Symbols.....4
- Features.....5
- Assembly.....5
- Operation.....6-9
- Maintenance.....9
- Illustrations10-11
- Parts Ordering and ServiceBack page

TABLE DES MATIÈRES

- Avertissements de sécurité générales relatives aux outils électriques.....2-3
- Avertissements de sécurité relatifs perceuses à percussion3
- Symboles.....4
- Caractéristiques5
- Assemblage.....5
- Utilisation6-9
- Entretien9
- Illustrations10-11
- Commande de pièces et dépannage Page arrière

ÍNDICE DE CONTENIDO

- Advertencias de seguridad para herramientas eléctrica 2-3
- Advertencias de seguridad de taladros de impacto.....3
- Símbolos.....4
- Características5
- Armado5
- Funcionamiento 6-9
- Mantenimiento.....9
- Ilustraciones..... 10-11
- Pedidos de piezas y servicio Pág. posterior

⚠ WARNING: To reduce the risk of injury, the user must read and understand the operator's manual before using this product.

⚠ AVERTISSEMENT : Pour réduire les risques de blessures, l'utilisateur doit lire et veiller à bien comprendre le manuel d'utilisation avant d'employer ce produit.

⚠ ADVERTENCIA: Para reducir el riesgo de lesiones, el usuario debe leer y comprender el manual del operador antes de usar este producto.

SAVE THIS MANUAL FOR FUTURE REFERENCE

CONSERVER CE MANUEL POUR FUTURE RÉFÉRENCE

GUARDE ESTE MANUAL PARA FUTURAS CONSULTAS

GENERAL POWER TOOL SAFETY WARNINGS



WARNING

Read all safety warnings and all instructions. Failure to follow the warnings and instructions may result in electric shock, fire and/or serious injury.

Save all warnings and instructions for future reference. The term “power tool” in the warnings refers to your mains-operated (corded) power tool or battery-operated (cordless) power tool.

WORK AREA SAFETY

- **Keep work area clean and well lit.** Cluttered or dark areas invite accidents.
- **Do not operate power tools in explosive atmospheres, such as in the presence of flammable liquids, gases or dust.** Power tools create sparks which may ignite the dust or fumes.
- **Keep children and bystanders away while operating a power tool.** Distractions can cause you to lose control.

ELECTRICAL SAFETY

- **Power tool plugs must match the outlet. Never modify the plug in any way. Do not use any adapter plugs with earthed (grounded) power tools.** Unmodified plugs and matching outlets will reduce risk of electric shock.
- **Avoid body contact with earthed or grounded surfaces such as pipes, radiators, ranges and refrigerators.** There is an increased risk of electric shock if your body is earthed or grounded.
- **Do not expose power tools to rain or wet conditions.** Water entering a power tool will increase the risk of electric shock.
- **Do not abuse the cord. Never use the cord for carrying, pulling or unplugging the power tool. Keep cord away from heat, oil, sharp edges or moving parts.** Damaged or entangled cords increase the risk of electric shock.
- **When operating a power tool outdoors, use an extension cord suitable for outdoor use.** Use of a cord suitable for outdoor use reduces the risk of electric shock.
- **If operating a power tool in a damp location is unavoidable, use a ground fault circuit interrupter (GFCI) protected supply.** Use of a GFCI reduces the risk of electric shock.
- **Use battery only with charger listed.** For use with 18V nickel-cadmium and 18V lithium-ion battery packs, see tool/appliance/battery pack/charger correlation supplement 987000-432.

PERSONAL SAFETY

- **Stay alert, watch what you are doing and use common sense when operating a power tool. Do not use a power tool while you are tired or under the influence of drugs, alcohol or medication.** A moment of inattention while operating power tools may result in serious personal injury.

- **Use personal protective equipment. Always wear eye protection.** Protective equipment such as dust mask, non-skid safety shoes, hard hat, or hearing protection used for appropriate conditions will reduce personal injuries.
- **Prevent unintentional starting. Ensure the switch is in the off-position before connecting to power source and/or battery pack, picking up or carrying the tool.** Carrying power tools with your finger on the switch or energising power tools that have the switch on invites accidents.
- **Remove any adjusting key or wrench before turning the power tool on.** A wrench or a key left attached to a rotating part of the power tool may result in personal injury.
- **Do not overreach. Keep proper footing and balance at all times.** This enables better control of the power tool in unexpected situations.
- **Dress properly. Do not wear loose clothing or jewellery. Keep your hair, clothing and gloves away from moving parts.** Loose clothes, jewellery or long hair can be caught in moving parts.
- **If devices are provided for the connection of dust extraction and collection facilities, ensure these are connected and properly used.** Use of dust collection can reduce dust-related hazards.
- **Do not wear loose clothing or jewelry. Contain long hair.** Loose clothes, jewelry, or long hair can be drawn into air vents.
- **Do not use on a ladder or unstable support.** Stable footing on a solid surface enables better control of the power tool in unexpected situations.

POWER TOOL USE AND CARE

- **Do not force the power tool. Use the correct power tool for your application.** The correct power tool will do the job better and safer at the rate for which it was designed.
- **Do not use the power tool if the switch does not turn it on and off.** Any power tool that cannot be controlled with the switch is dangerous and must be repaired.
- **Disconnect the plug from the power source and/or the battery pack from the power tool before making any adjustments, changing accessories, or storing power tools.** Such preventive safety measures reduce the risk of starting the power tool accidentally.
- **Store idle power tools out of the reach of children and do not allow persons unfamiliar with the power tool or these instructions to operate the power tool.** Power tools are dangerous in the hands of untrained users.
- **Maintain power tools. Check for misalignment or binding of moving parts, breakage of parts and any other condition that may affect the power tool's operation. If damaged, have the power tool repaired before use.** Many accidents are caused by poorly maintained power tools.

GENERAL POWER TOOL SAFETY WARNINGS

- **Keep cutting tools sharp and clean.** Properly maintained cutting tools with sharp cutting edges are less likely to bind and are easier to control.
- **Use the power tool, accessories and tool bits etc. in accordance with these instructions, taking into account the working conditions and the work to be performed.** Use of the power tool for operations different from those intended could result in a hazardous situation.

BATTERY TOOL USE AND CARE

- **Recharge only with the charger specified by the manufacturer.** A charger that is suitable for one type of battery pack may create a risk of fire when used with another battery pack.
- **Use power tools only with specifically designated battery packs.** Use of any other battery packs may create a risk of injury and fire.
- **When battery pack is not in use, keep it away from other metal objects, like paper clips, coins, keys, nails,**

screws, or other small metal objects, that can make a connection from one terminal to another. Shorting the battery terminals together may cause burns or a fire.

- **Under abusive conditions, liquid may be ejected from the battery; avoid contact. If contact accidentally occurs, flush with water. If liquid contacts eyes, additionally seek medical help.** Liquid ejected from the battery may cause irritation or burns.

SERVICE

- **Have your power tool serviced by a qualified repair person using only identical replacement parts.** This will ensure that the safety of the power tool is maintained.
- **When servicing a power tool, use only identical replacement parts. Follow instructions in the Maintenance section of this manual.** Use of unauthorized parts or failure to follow Maintenance instructions may create a risk of shock or injury.



HAMMER DRILL SAFETY WARNINGS

- **Wear ear protectors with impact drilling.** Exposure to noise can cause hearing loss.
- **Use auxiliary handle(s), if supplied with the tool.** Loss of control can cause personal injury.
- **Hold power tool by insulated gripping surfaces, when performing an operation where the cutting accessory may contact hidden wiring.** Cutting accessory contacting a “live” wire may make exposed metal parts of the power tool “live” and could give the operator an electric shock.
- **Know your power tool. Read operator’s manual carefully. Learn its applications and limitations, as well as the specific potential hazards related to this power tool.** Following this rule will reduce the risk of electric shock, fire, or serious injury.
- **Always wear eye protection with side shields marked to comply with ANSI Z87.1 when assembling parts, operating the tool, or performing maintenance.** Following this rule will reduce the risk of serious personal injury.
- **Protect your lungs. Wear a face or dust mask if the operation is dusty.** Following this rule will reduce the risk of serious personal injury.
- **Protect your hearing. Wear hearing protectors during extended periods of operation.** Following this rule will reduce the risk of serious personal injury.
- **Battery tools do not have to be plugged into an electrical outlet; therefore, they are always in operating condition. Be aware of possible hazards when not using your battery tool or when changing accessories.** Following this rule will reduce the risk of electric shock, fire, or serious personal injury.





- **Do not place battery tools or their batteries near fire or heat.** This will reduce the risk of explosion and possibly injury.
- **Do not crush, drop or damage battery pack. Do not use a battery pack or charger that has been dropped or received a sharp blow.** A damaged battery is subject to explosion. Properly dispose of a dropped or damaged battery immediately.
- **Batteries can explode in the presence of a source of ignition, such as a pilot light.** To reduce the risk of serious personal injury, never use any cordless product in the presence of open flame. An exploded battery can propel debris and chemicals. If exposed, flush with water immediately.
- **Do not charge battery tool in a damp or wet location.** Following this rule will reduce the risk of electric shock.
- **For best results, your battery tool should be charged in a location where the temperature is more than 50°F but less than 100°F.** To reduce the risk of serious personal injury, do not store outside or in vehicles.
- **Under extreme usage or temperature conditions, battery leakage may occur. If liquid comes in contact with your skin, wash immediately with soap and water. If liquid gets into your eyes, flush them with clean water for at least 10 minutes, then seek immediate medical attention.** Following this rule will reduce the risk of serious personal injury.
- **Save these instructions.** Refer to them frequently and use them to instruct others who may use this tool. If you loan someone this tool, loan them these instructions also.

SYMBOLS

The following signal words and meanings are intended to explain the levels of risk associated with this product.

SYMBOL	SIGNAL	MEANING
	DANGER:	Indicates an imminently hazardous situation, which, if not avoided, will result in death or serious injury.
	WARNING:	Indicates a potentially hazardous situation, which, if not avoided, could result in death or serious injury.
	CAUTION:	Indicates a potentially hazardous situation, which, if not avoided, may result in minor or moderate injury.
	NOTICE:	(Without Safety Alert Symbol) Indicates important information not related to an injury hazard, such as a situation that may result in property damage.

Some of the following symbols may be used on this product. Please study them and learn their meaning. Proper interpretation of these symbols will allow you to operate the product better and safer.

SYMBOL	NAME	DESIGNATION/EXPLANATION
	Safety Alert	Indicates a potential personal injury hazard.
	Read Operator's Manual	To reduce the risk of injury, user must read and understand operator's manual before using this product.
	Eye Protection	Always wear eye protection with side shields marked to comply with ANSI Z87.1.
	Wet Conditions Alert	Do not expose to rain or use in damp locations.
	Recycle Symbols	This product uses nickel-cadmium (Ni-Cd) and lithium-ion (Li-ion) batteries. Local, state or federal laws may prohibit disposal of batteries in ordinary trash. Consult your local waste authority for information regarding available recycling and/or disposal options.
V	Volts	Voltage
min	Minutes	Time
—	Direct Current	Type or a characteristic of current
n_0	No Load Speed	Rotational speed, at no load
.../min	Per Minute	Revolutions, strokes, surface speed, orbits etc., per minute

FEATURES

PRODUCT SPECIFICATIONS

No Load Speed	0-375/0-1,600 r/min. (RPM)	Torque.....	600 in.lb.
Clutch.....	24 position	Hammer Speed (Blows per minute)	0-5,600/0-24,000 BPM

ASSEMBLY

UNPACKING

This product requires assembly.

- Carefully remove the tool and any accessories from the box. All items listed in the **Includes** section must be included at the time of purchase.

WARNING:

Items in this *Assembly* section are not assembled to the product by the manufacturer and require customer installation. Use of a product that may have been improperly assembled could result in serious personal injury.

- If any parts are damaged or missing, please call 1-800-525-2579 for assistance.

WARNING:

If any parts are damaged or missing do not operate this product until the parts are replaced. Use of this product with damaged or missing parts could result in serious personal injury.

WARNING:

Do not attempt to modify this product or create accessories or attachments not recommended for use with this product. Any such alteration or modification is misuse and could result in a hazardous condition leading to possible serious personal injury.

INSTALLING/ADJUSTING THE AUXILIARY HANDLE ASSEMBLY

See Figure 1, page 10.

An auxiliary handle is packed with the drill for ease of operation and to help prevent loss of control. The handle can be mounted for left or right hand use.

- Insert the handle screw into the hole located above the trigger switch and seat the hex head into the hole.
- Slide the handle collar onto the screw. Seat the hex end of the collar into the hex hole.

NOTE: Be sure the hex hole for the depth stop rod sits on top of the collar.

- Slide the depth stop rod into the hex-shaped hole on top of the collar.
- Slide the depth stop rod clamp into the notch in the collar. The clamp holds the depth rod firmly in place.

NOTE: When properly installed, the teeth on the depth stop rod should be facing the direction of the handle.

- Thread the auxiliary handle onto the screw and secure tightly.

NOTE: Be sure the the auxiliary handle is securely tightened against the depth stop rod clamp. This secures the depth stop rod at the desired depth of cut. It also secures the auxiliary handle.

OPERATION

WARNING:

Do not allow familiarity with this product to make you careless. Remember that a careless fraction of a second is sufficient to inflict serious injury.

WARNING:

Always remove battery pack from the tool when you are assembling parts, making adjustments, cleaning, or when not in use. Removing battery pack will prevent accidental starting that could cause serious personal injury.

WARNING:

Always wear eye protection with side shields marked to comply with ANSI Z87.1, along with hearing protection. Failure to do so could result in objects being thrown into your eyes and other possible serious injuries.

WARNING:

Do not use any attachments or accessories not recommended by the manufacturer of this product. The use of attachments or accessories not recommended can result in serious personal injury.

APPLICATIONS

You may use this product for the purposes listed below:

- Hammer drilling in concrete, brick, or other masonry
- Drilling in all types of wood products (lumber, plywood, paneling, composition board, and hard board), ceramics, plastics, fiberglass, laminates, and metals; driving screws into wood and drywall with screwdriver bits

VARIABLE SPEED SWITCH TRIGGER

See Figure 2, page 10.

The variable speed switch trigger delivers higher speed with increased trigger pressure and lower speed with decreased trigger pressure.

To turn the tool **ON**, depress the switch trigger. To turn it **OFF**, release the switch trigger and allow the chuck to come to a complete stop.

NOTE: A whistling or ringing noise coming from the switch during use is a normal part of the switch function.

NOTE: Running at low speeds under constant usage may cause the drill to become overheated. If this occurs, cool the drill by running it without a load and at full speed.

DIRECTION OF ROTATION SELECTOR (FORWARD/REVERSE/CENTER LOCK)

See Figure 2, page 10.

Set the direction of rotation selector in the **OFF** (center lock) position to lock the switch trigger and help prevent accidental starting when not in use.

Position the direction of rotation selector to the left of the switch trigger for forward drilling. Position the selector to the right of the switch trigger to reverse the direction.

NOTE: The drill will not run unless the direction of rotation selector is pushed fully to the left or right.

NOTICE:

To prevent gear damage, always allow the chuck to come to a complete stop before changing the direction of rotation.

WARNING:

Battery tools are always in operating condition. Lock the switch when not in use or carrying at your side, when installing or removing the battery pack, and when installing or removing bits.

INSTALLING/REMOVING BATTERY PACK

See Figure 3, page 10.

- Lock the switch trigger.
- Insert the battery pack into the product as shown.
- Make sure the latches on each side of the battery pack snap in place and that battery pack is secured in the product before beginning operation.
- Depress the latches to remove the battery pack.

For complete charging instructions, see the operator's manuals for your battery pack and charger.

INSTALLING/REMOVING BITS

See Figures 4 - 5, page 10.

The arrows on the keyless chuck indicate which direction to rotate the chuck **sleeve** to tighten or release the drill bit.

Do not use a wrench to tighten or loosen the chuck jaws.

- **To install bits**, lock the switch trigger.
- Open or close the chuck jaws until the opening is slightly larger than the bit size you intend to use.
- Raise the front of the drill slightly and insert the drill bit.

WARNING:

Make sure to insert the drill bit straight into the chuck jaws. Do not insert the drill bit into the chuck jaws at an angle, then tighten. This could cause the drill bit to be thrown from the drill, resulting in possible serious personal injury or damage to the chuck.

OPERATION

WARNING:

Do not hold the chuck sleeve with one hand and use the power of the drill to tighten the chuck jaws on the drill bit. The chuck body could slip in your hand, or your hand could slip and come in contact with the rotating drill bit. This could cause an accident resulting in serious personal injury.

- **To remove bits**, lock the switch trigger and open the chuck jaws.
- The bit provided with the drill can be placed in the storage area, located on the base of the drill.

TWO-SPEED GEAR TRAIN (HI-LO SWITCH)

See Figure 6, page 11.

- Select **LOW (1)** speed for applications requiring higher power and torque.
- Select **HIGH (2)** speed for fast drilling, hammer drilling or driving applications.

NOTICE:

Never change speeds while the tool is running. Failure to obey this caution could result in serious damage to the drill.

NOTE: If you have difficulty changing from one gear range to the other, turn the chuck by hand until the gears engage.

QUICK MODE SELECTOR

See Figure 7, page 11.

The Quick Mode Selector allows you to quickly switch from drill mode to drive mode.

Drill mode should be used for drilling and other heavy duty applications. Drive mode should be used for driving screws. Hammer mode should be used for hammer drilling.

Using the chart, select the option that best matches the type of bit, fastener, and material you will be using.

- Choose your **APPLICATION**.
- Choose the correct **SPEED: (1/LOW OR 2/HIGH)**
- Choose the correct **MODE: (DRIVE, DRILL, OR HAMMER)**

ADJUSTING TORQUE



See Figure 8, page 11.

When using the drill-driver for various driving applications, increasing or decreasing the torque helps prevent the possibility of damaging screw heads, threads, workpiece, etc. In general, torque intensity should correspond to the screw diameter. If the torque is too high or the screws too small, the screws may be damaged or broken.

The torque is adjusted by rotating the torque adjustment ring.

The torque is greater when the torque adjustment ring is set on a higher setting. The torque is less when the torque adjustment ring is set on a lower setting.

The proper setting depends on the type of material and the size of screw you are using.

APPLICATION	SPEED	MODE
<ul style="list-style-type: none"> • Lag screws up to 3/8 in. dia. by 1-1/2 in. long • Hole saw up to 2 in. • Spade bits up to 1-1/2 in. • Drill bits up to 1/2 in. • Drilling into metal • Concrete screws 	1/LOW	DRILL MODE (TORQUE ADJUSTMENT NOT ACTIVE) 
	2/HIGH	
<ul style="list-style-type: none"> • Deck or wood screws up to 3 in. • Self tapping screws 	1/LOW	DRIVE MODE 
<ul style="list-style-type: none"> • Deck or wood screws up to 2 in. • Small screws or delicate work that requires more control 	2/HIGH	
<ul style="list-style-type: none"> • Drilling into masonry and concrete. 	2/HIGH	HAMMER MODE (TORQUE ADJUSTMENT NOT ACTIVE) 

OPERATION

ADJUSTING THE AUXILIARY HANDLE ASSEMBLY

See Figure 9, page 11.

To adjust the auxiliary handle assembly:

- Loosen the handle assembly by turning the handle counterclockwise.
- Insert the auxiliary handle assembly in the desired operating position.
- Securely tighten by turning the auxiliary handle clockwise.

NOTE: Be sure the auxiliary handle is securely tightened against the depth stop rod clamp. This secures the depth stop rod at the desired depth of cut. It also secures the auxiliary handle.

ADJUSTING THE DEPTH STOP ROD

See Figure 9, page 11.

The depth stop rod helps control the depth of drilled holes.

To adjust the depth stop rod:

- Lock the switch trigger by placing the direction of rotation selector in the center position.
- Loosen the auxiliary handle assembly by turning the knob counterclockwise.
- Adjust the depth stop rod so that the drill bit extends beyond the end of the rod to the required drilling depth.
- Tighten the auxiliary handle assembly by turning the knob clockwise.

NOTE: When properly installed, the teeth on the depth stop rod should be facing the direction of the handle.

DRILLING/DRIVING SCREWS

See Figure 10, page 11.

WARNING:

Always use the auxiliary handle when using this tool to help resist torque reactions. Binding or stalling of this product could lead to serious personal injury.

- Install the auxiliary handle.
- Check the direction of rotation selector for the correct setting (forward or reverse).

- Use **LOW (1)** speed for high torque applications and **HIGH (2)** speed for fast drilling or driving applications. Refer to **Two-Speed Gear Train** and **Adjusting Torque**.
- Secure the workpiece in a vise or with clamps to keep it from turning as the bit rotates.
- Hold the drill firmly and place the bit at the point to be drilled, or where the screw is to be driven.

WARNING:

Do not drive a screw where there is likely to be hidden wiring behind the surface. Contact with a “live” wire will make exposed metal parts of the tool “live” and possibly shock the operator. If you must drive a screw where hidden wire may be present, always hold tool by insulated gripping surfaces (handle) when performing the operation to prevent a shock to the operator.

- Depress the switch trigger to start the drill.
- Move the bit into the workpiece, applying only enough pressure to keep the bit cutting or driving the screw. Do not force the drill or apply side pressure to elongate a hole. Let the tool do the work.

WARNING:

When drilling, be prepared for binding at bit breakthrough. When these situations occur, drill has a tendency to grab and kick opposite to the direction of rotation and could cause loss of control when breaking through material. If not prepared, this loss of control can result in possible serious injury.

- When drilling hard, smooth surfaces, use a center punch to mark the desired hole location. This will prevent the bit from slipping off-center as the hole is started.
- If the bit jams in the workpiece or if the drill stalls, stop the tool immediately. Remove the bit from the workpiece and determine the reason for jamming.

NOTE: This drill has an electric brake. When the switch trigger is released, the chuck stops turning. When the brake is functioning properly, sparks will be visible through the vent slots on the housing. This is normal and is the action of the brake.

OPERATION

WOOD AND METAL DRILLING

For maximum performance, use high speed steel bits for wood or metal drilling. Select drilling mode. Begin drilling at a very low speed to prevent the bit from slipping off the starting point.

Wood Drilling

- Increase the speed as the drill bit bites into the material.
- When drilling through holes, place a block of wood behind the workpiece to prevent ragged or splintered edges on the back side of the hole.

Metal and Steel Drilling

- Use a light oil on the drill bit to keep it from overheating. The oil will prolong the life of the bit and increase the drilling action.
- Maintain a speed and pressure which allows cutting without overheating the bit. Applying too much pressure will:
 - Overheat the drill;
 - Wear the bearings;

- Bend or burn bits; and
- Produce off-center or irregular-shaped holes.

- When drilling large holes in metal, start with a small bit, then finish with a larger bit.

MASONRY DRILLING

For maximum performance, use carbide-tipped masonry impact bits or designated hammer drill bits when drilling holes in brick, tile, concrete, etc. Select hammer mode.

- Apply light pressure at medium speed for best results in brick.
- Apply additional pressure for hard materials such as concrete.
- When drilling holes in tile, practice on a scrap piece to determine the best speed and pressure. Begin drilling at a very low speed to prevent the bit from slipping off the starting point.

MAINTENANCE

WARNING:

When servicing, use only identical replacement parts. Use of any other parts could create a hazard or cause product damage.

GENERAL MAINTENANCE

Avoid using solvents when cleaning plastic parts. Most plastics are susceptible to damage from various types of commercial solvents and may be damaged by their use. Use clean cloths to remove dirt, dust, oil, grease, etc.

CALIFORNIA PROPOSITION 65

WARNING:

This product and some dust created by power sanding, sawing, grinding, drilling, and other construction activities may contain chemicals, including lead, known to the State of California to cause cancer, birth defects, or other reproductive harm. **Wash hands after handling.**

Some examples of these chemicals are:

- lead from lead-based paints,
- crystalline silica from bricks and cement and other masonry products and,
- arsenic and chromium from chemically treated lumber.

Your risk from exposure to these chemicals varies, depending on how often you do this type of work. To reduce your exposure, work in a well-ventilated area and with approved safety equipment, such as dust masks that are specially designed to filter out microscopic particles.

NOTE: ILLUSTRATIONS START ON PAGE 10 AFTER FRENCH AND SPANISH LANGUAGE SECTIONS.

P214

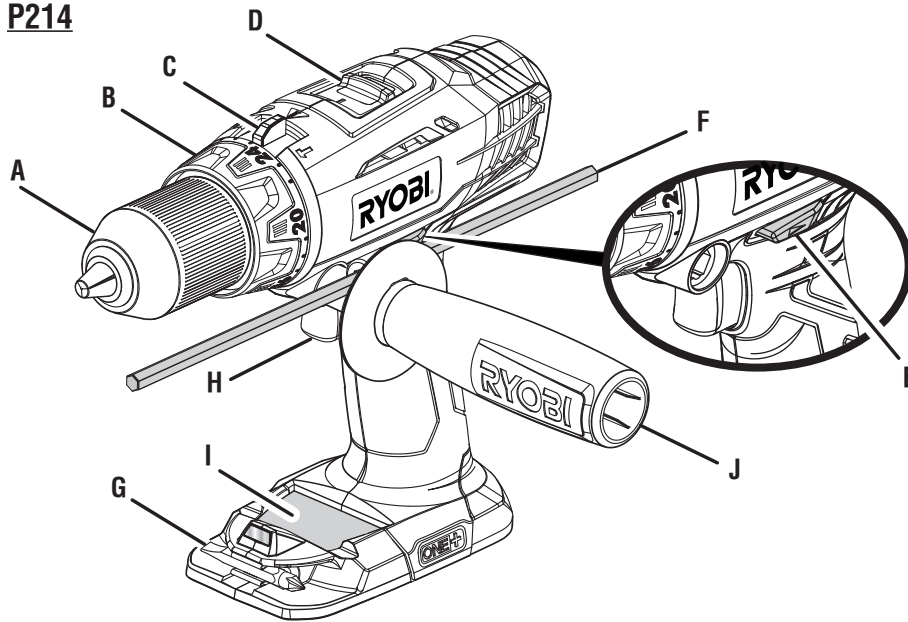

- A - Keyless chuck (mandrin sans clé, portabrocas de apriete sin llave)
- B - Torque adjustment ring (bague de réglage du couple, anillo de ajuste de fuerza de torsión)
- C - Quick mode selector (sélecteur de mode rapide, selector de modo rápido)
- D - Two-speed gear train (high-low) [train d'engrenages à deux vitesses (haute et basse, engranaje de dos velocidades (alta-baja)]
- E - Direction of rotation selector (forward/reverse/center lock) [sélecteur de sens de rotation (avant / arrière / verrouillage central), selector de sentido de rotación (adelante / atrás / seguro en el centro)]
- F - Depth stop rod (tige de butée de profondeur, barra limitadora de profundidad)
- G - Bit storage (rangement d'embouts, compartimiento de puntas)
- H - Switch trigger (gâchette, gatillo del interruptor)
- I - MagTray™ (MagTray™, MagTray™)
- J - Auxiliary handle (poignée auxiliaire, mango auxiliar)

Fig. 1

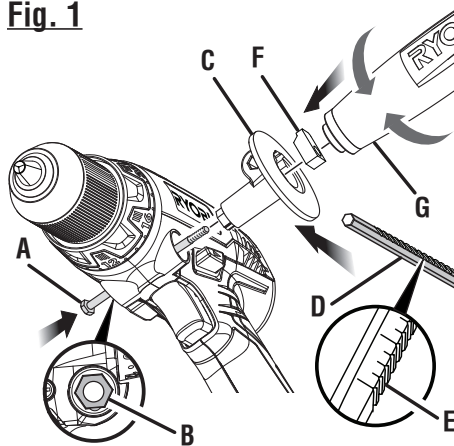

- A - Handle screw (vis de poignée, tornillo del mango)
- B - Hex head hole (trou hexagonal, orificio de la cabeza hexagonal)
- C - Handle collar (collier de la poignée, collar del mango)
- D - Depth stop rod (tige de butée de profondeur, barra limitadora de profundidad)
- E - Teeth (dents, dientes)
- F - Depth stop rod clamp (bride de la tige de butée de profondeur, mordaza de la barra limitadora de profundidad)
- G - Auxiliary handle (poignée auxiliaire, mango auxiliar)

Fig. 2

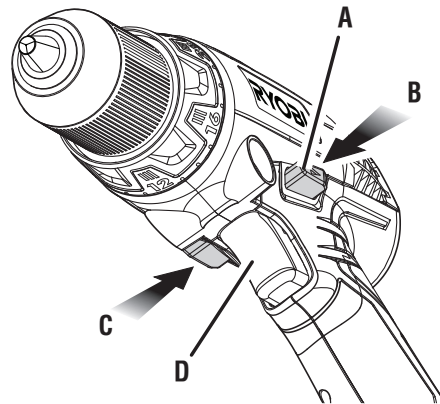

- A - Direction of rotation selector (forward/reverse/center lock) [sélecteur de sens de rotation (avant / arrière / verrouillage central), selector de sentido de rotación (adelante / atrás / seguro en el centro)]
- B - Reverse (rotation arrière, marcha atrás)
- C - Forward (rotation avant, marcha adelante)
- D - Switch trigger (gâchette, gatillo del interruptor)

Fig. 3

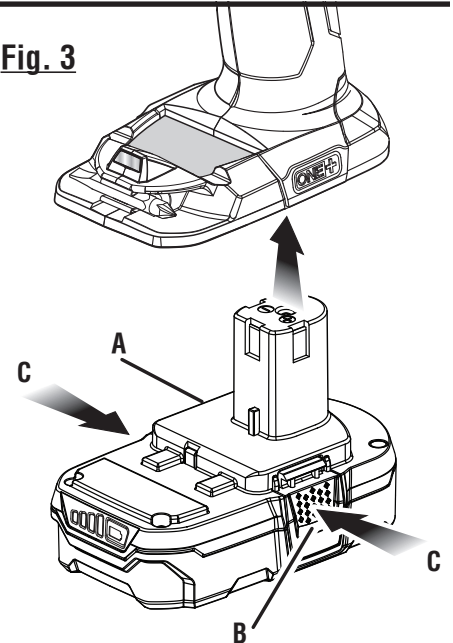

- A - Battery pack (bloc-pile, paquete de batería)
- B - Latches (loquets, pestillos)
- C - Depress latches to release battery pack (appuyer sur les loquets pour libérer le bloc-piles, para soltar el paquete de baterías oprima los pestillos)

Fig. 4

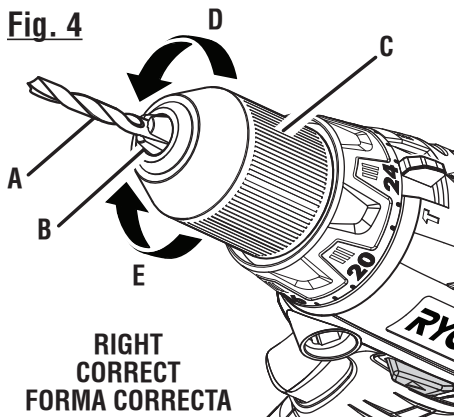

- A - Drill bit (foret, broca)
- B - Chuck jaws (mors du mandrin, mordazas del portabrocas)
- C - Chuck sleeve (collet du mandrin, collar del portabrocas)
- D - Unlock (release) [unlock (desserage), unlock (aflojar)]
- E - Lock (tighten) [lock (serrage), lock (apretar)]

Fig. 5

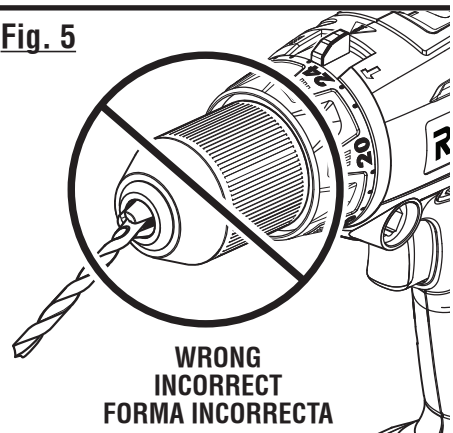

**WRONG
INCORRECT
FORMA INCORRECTA**

Fig. 6

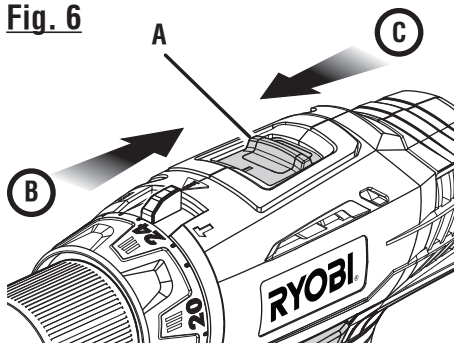

- A - Two-speed gear train [HIGH (2) – LOW (1)] [train d'engrenages à deux vitesses (haute et basse, engranaje de dos velocidades (alta-baja)]
- B - Low speed (basse vitesse, velocidad baja)
- C - High speed (haute vitesse, velocidad alta)

Fig. 7

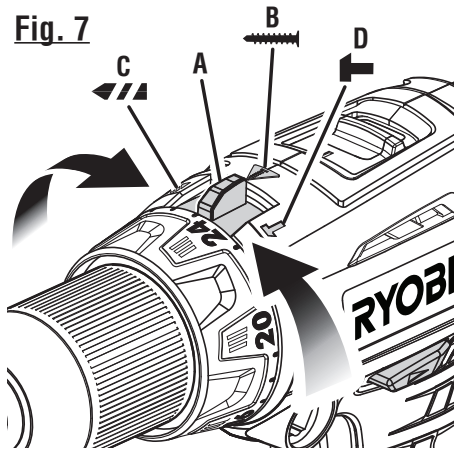

- A - Quick mode selector (sélecteur de mode rapide, selector de modo rápido)
- B - Drive mode (mode de vissage, modo de atornillado)
- C - Drill mode, "torque adjustment not active" (mode de perçage "réglage de couple désactive", modo de taladrado "ajuste de fuerza de torsion inactivo")
- D - Hammer mode "torque adjustment not active" (mode de percussion "réglage de couple désactive", modo de percusión "ajuste de fuerza de torsion inactivo")

Fig. 8

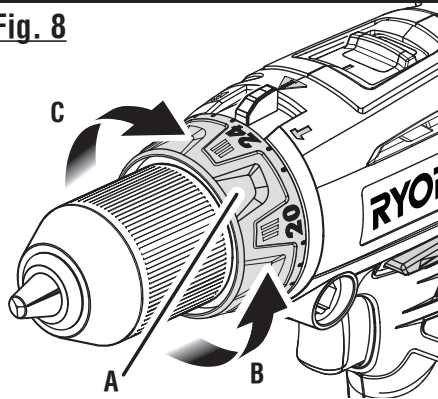

- A - Torque adjustment ring (bague de réglage du couple, anillo de ajuste de fuerza de torsión)
- B - To decrease torque (pour réduire le couple, para disminuir la fuerza de torsión)
- C - To increase torque (pour augmenter le couple, para aumentar la fuerza de torsión)

Fig. 9

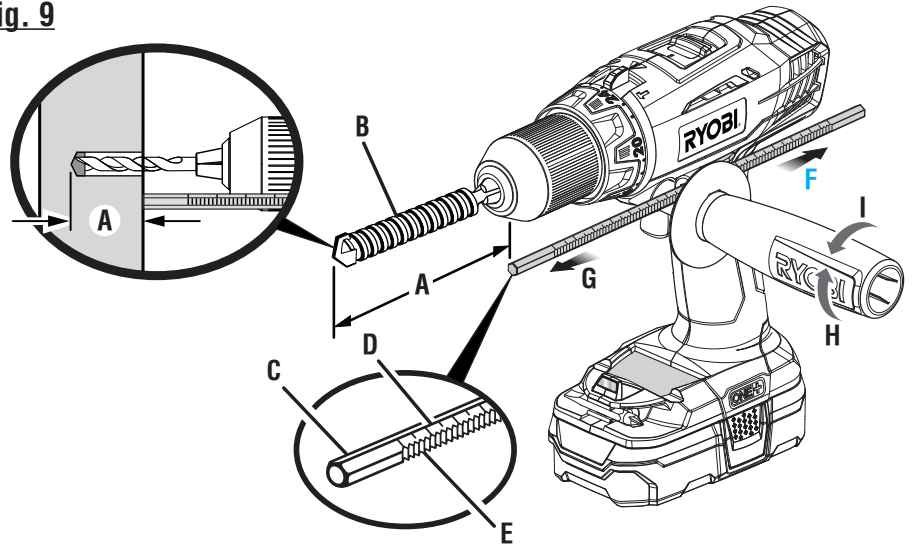

- A - Drilling depth (profondeur de perçage, profundidad de taladrado)
- B - Drill bit (foret, broca)
- C - Depth stop rod (tige de butée de profondeur, barra limitadora de profundidad)
- D - Scale (échelle, indicador de la escala)
- E - Teeth (dents, dientes)
- F - To increase drilling depth (pour augmenter la profondeur de perçage, para aumentar la profundidad de taladrado)
- G - To decrease drilling depth (pour réduire la profondeur de perçage, para disminuir la profundidad de taladrado)
- H - To tighten (pour serrer, para apretar)
- I - To loosen (pour desserrer, para aflojar)

Fig. 10

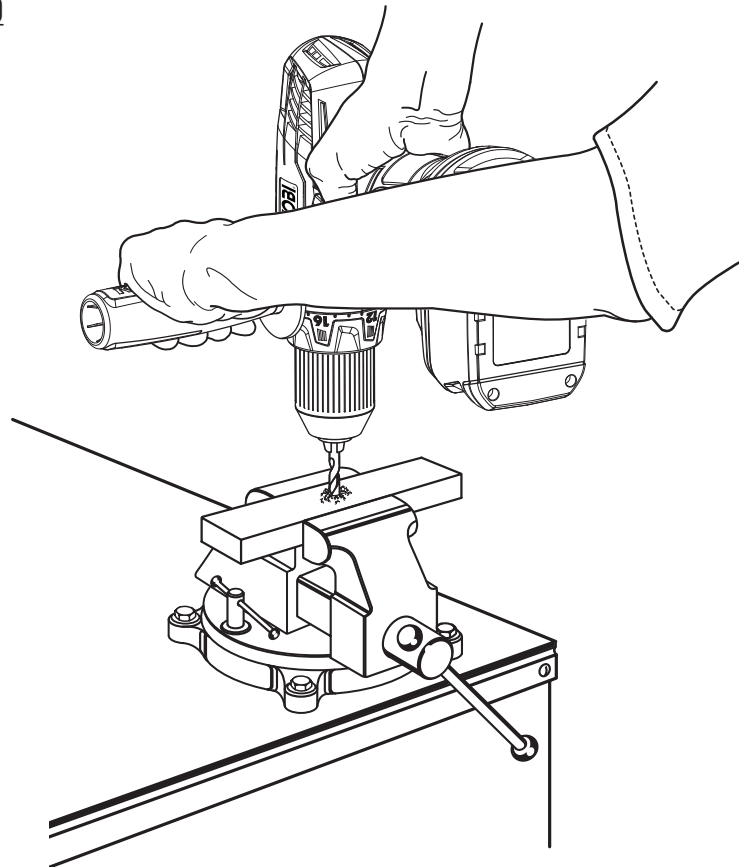



OPERATOR'S MANUAL 18 VOLT HAMMER DRILL

MANUEL D'UTILISATION

PERCEUSE À PERCUSSION DE 18 V

MANUAL DEL OPERADOR

TALADRO DE PERCUSIÓN DE 18 V

P214

To request service, purchase replacement parts,
locate an Authorized Service Center and obtain Customer or Technical Support:

Visit **www.ryobitools.com** or call **1-800-525-2579**

If any parts or accessories are damaged or missing,
do not return this product to the store. Call **1-800-525-2579** for immediate service.

Please obtain your model and serial number from the product data plate.

MODEL NUMBER _____ SERIAL NUMBER _____

RYOBI is a registered trademark of Ryobi Limited and is used pursuant to a license granted by Ryobi Limited.

Pour faire une demande de réparations ou obtenir des pièces de rechange, trouver un
Centre de réparations agréé pour obtenir un soutien technique ou le Service à la clientèle :

Visiter **www.ryobitools.com** ou en téléphonant au **1-800-525-2579**

Si des pièces ou accessoires sont manquantes ou endommagées, ne pas retourner
ce produit au magasin. Appeler immédiatement au **1-800-525-2579** pour obtenir de l'aide.

Inscrire les numéros de modèle et de série inscrits sur la plaque d'identification du produit.

NUMÉRO DE MODÈLE _____ NUMÉRO DE SÉRIE _____

RYOBI est une marque déposée de Ryobi Limited et est utilisée en vertu d'une licence accordée par Ryobi Limited.

Para obtener servicio, comprar piezas de repuesto, localizar un centro de servicio autorizado
y obtener Servicio o Asistencia Técnica al Consumidor:

Visite **www.ryobitools.com** (en la EE.UU.) o **www.ryobitools.mx** (en México)
o llame al **1-800-525-2579** (en la EE.UU.) o **01-800-843-1111** (en México).

Si hay alguna pieza o accesorios dañada o faltante, no devuelva este producto a la tienda.
Llame al **1-800-525-2579** (en la EE.UU.) o **01-800-843-1111** (en México) para servicio técnico inmediato.

Obtenga su modelo y número de serie de la placa de datos del producto.

NÚMERO DE MODELO _____ NÚMERO DE SERIE _____

RYOBI es una marca registrada de Ryobi Limited y se utiliza conforme a una licencia otorgada por Ryobi Limited.

ONE WORLD TECHNOLOGIES, INC.

1428 Pearman Dairy Road, Anderson, SC 29625 • Phone 1-800-525-2579

États-Unis, Téléphone 1-800-525-2579 • USA, Teléfono 1-800-525-2579

www.ryobitools.com

991000307

A subsidiary of Techtronic Industries Co., LTD OTC: TTNDY

10-28-14 (REV:01)