



# SERVICE PARTS LIST

BULLETIN NO.  
54-07-2320

SPECIFY CATALOG NO. AND SERIAL NO. WHEN ORDERING PARTS				REVISED BULLETIN	DATE
<b>12 VOLT M-SPECTOR 2 (Digital Inspection Camera)</b>					Feb. 2012
CATALOG NO.	2311-20	SERIAL NUMBER	C20A	WIRING INSTRUCTION	

**EXAMPLE:**  

00	0
----	---

 Component Parts (Small #) Are Included  
 When Ordering The Assembly (Large #).

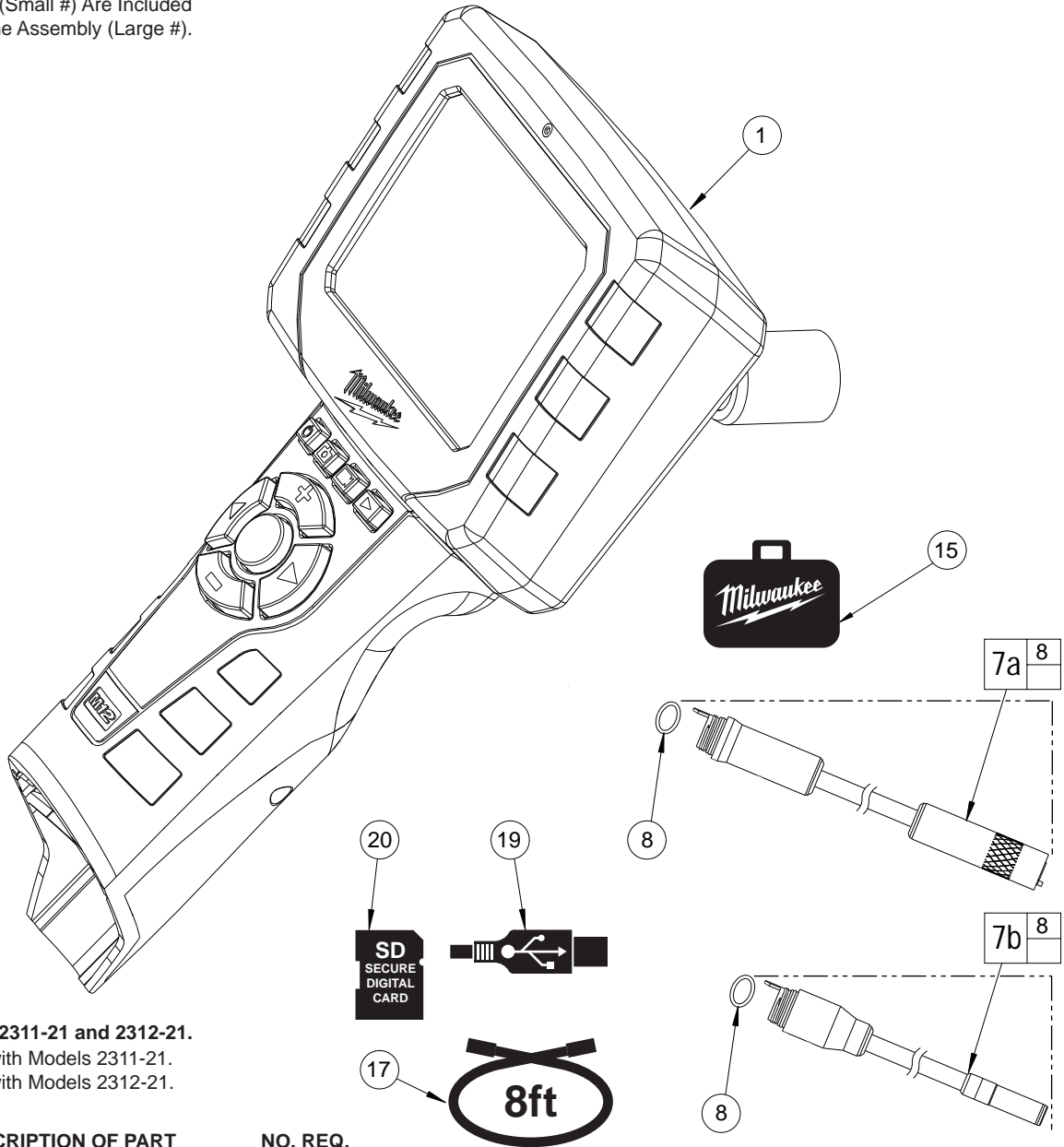

**2311-20: Base model for 2311-21 and 2312-21.**

\* Standard equipment with Models 2311-21.

\*\* Standard equipment with Models 2312-21.

FIG.	PART NO.	DESCRIPTION OF PART	NO. REQ.
1	14-46-2311	Inspection Camera	(1)
7a	48-53-0125	Digital Camera Cable *	(1)
7b	48-53-0130	Analog Camera Cable **	(1)
8	34-40-0195	O-Ring	(1)
15	42-55-2311	Carrying Case	(1)
16	12-20-0705	Service Nameplate (Not Shown)	(1)
17	48-53-0140	Accessory 8' Extension Cable	(1)
19	42-44-0200	USB (Universal Serial Bus) Cable	(1)
20	22-74-3000	SD (Secure Digital) Card	(1)