



EasyClean[®], EasyClean[®] High Capacity & EasyClean[®] Extra High Capacity Box Operation and Maintenance Guide

1380 Beverage Drive, Suite W
Stone Mountain, GA 30083
1-800-426-6256 | 678-892-2323

Better – Faster – Every time

**Models: 20TTX, 25TTX, 30TTX, 22TT, 27TT, 32TT,
EZ07H, EZ10H, EZ12H, EHC07, EHC10, EHC12**

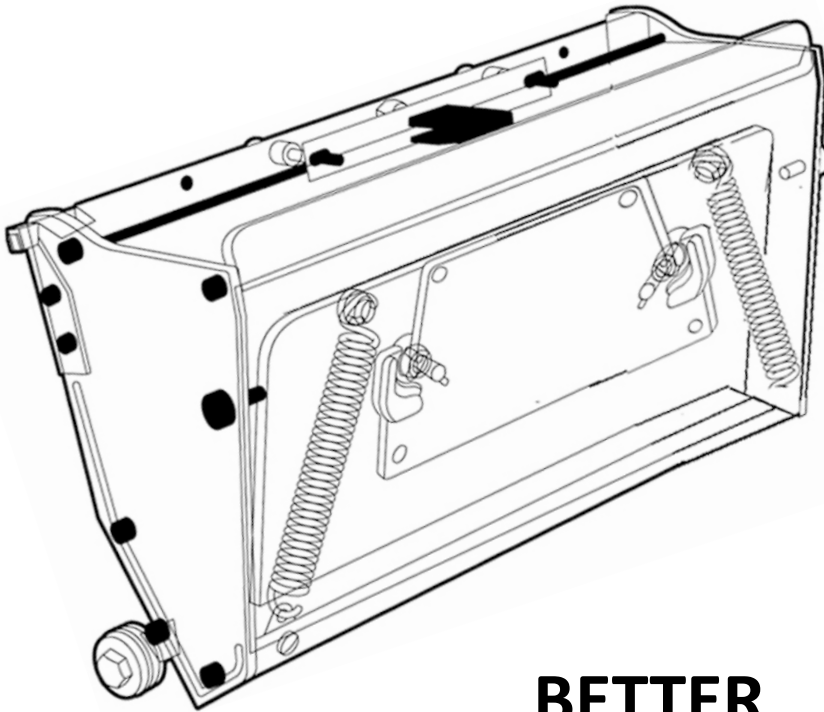

**BETTER
FASTER
EVERY TIME**

EasyClean®, EasyClean® High Capacity & EasyClean® Extra High Capacity Box Operation and Maintenance Guide

1380 Beverage Drive, Suite W
Stone Mountain, GA 30083
1-800-426-6256 | 678-892-2323

Better – Faster – Every time

Models: 20TTX, 25TTX, 30TTX, 22TT, 27TT, 32TT, EZ07H, EZ10H, EZ12H, EHC07, EHC10, EHC12

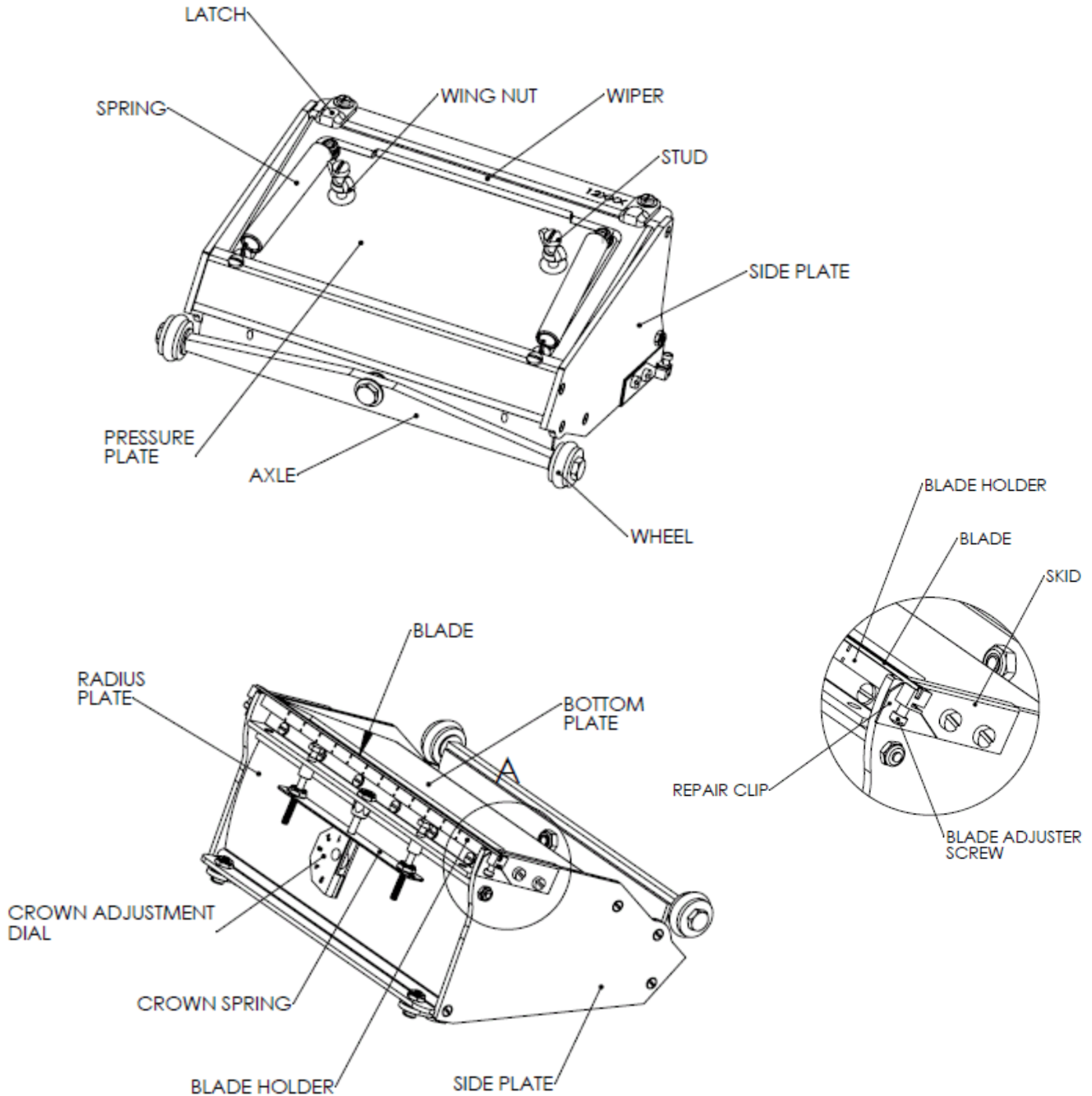

Models: 20TTX, 25TTX, 30TTX, 22TT, 27TT, 32TT, EZ07H, EZ10H, EZ12H, EHC07, EHC10, EHC12

Operation

The EasyClean® finishing box , EasyClean® High Capacity and EasyClean® Extra High Capacity Finishing boxes apply joint compound over taped joints. They come in three widths, generally used for finishing as follows:

- 7" (175 mm): applies bed coat
- 10" (250 mm): applies finish coat
- 12" (300 mm): applies skim coat

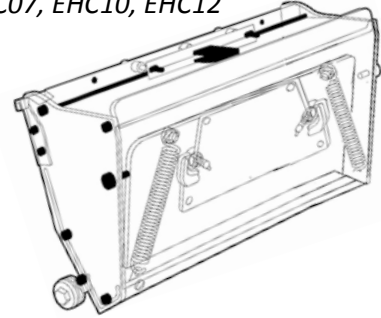

These tools require little effort to operate and are designed to produce uniform results every time. The difference in the two boxes are their capacity and cleaning; the EasyClean® High Capacity Box and Extra High Capacity Box holds more joint compound and is even easier to clean because the back opens even more than the standard EasyClean™ boxes.

The boxes are controlled by a specially designed handle. These handles come in multiple lengths from 34" to 72" as well as an XTender™ Handle that adjusts between 41" and 63". The handle is attached to the box by sliding the box onto the handle and tightening the two wing nuts.

Load the box through the opening behind the blade using the box adapter with the slot adapter inserted.

To apply compound, draw the box steadily along the joint while applying pressure with the handle. This dispenses compound through the opening at a steady rate. The tool is always run with the wheels leading and the blade trailing. The handle should lead the box, except at the end of joints.

The adjustable metal blade trowels the compound with the precise crown needed. This is set using the crown adjustment wheel. This dial controls the amount of crown left by the box with #1 being the most and #5 the least.

Before starting to run any joint, lock the box handle at a slight angle by squeezing the handle grip with one hand. Your other hand should grip the handle near the box.

Place the box at the end of the joint and apply pressure with the handle to start the compound flowing. Release the hand grip to unlock the handle and allow it to find its own natural position. Draw the tool along the joint, leading with the handle and applying pressure to distribute the joint compound onto the wallboard surface.

Near the middle of the joint, lock the handle and by gradually decreasing pressure, remove the box from the wallboard surface with a sweeping motion.

Reverse hand positions and begin again at the other end of the joint. Again draw the box along until you reach the previous stopping point. Lock the handle and remove the box from the surface with a sweeping motion. This procedure is followed for all ceiling joints and horizontal wall joints.



EasyClean[®], EasyClean[®] High Capacity & EasyClean[®] Extra High Capacity Box Operation and Maintenance Guide

1380 Beverage Drive, Suite W
Stone Mountain, GA 30083
1-800-426-6256 | 678-892-2323

Better – Faster – Every time

Operation (continued)

To cover vertical wall joints, lock the handle and begin covering the joint from the bottom up to a height of about 30" (.75 m), sweep off and begin again at the top of the joint.

Draw down the joint until you reach the previous stopping point. Then lock the handle and sweep off the surface, neatly joining the two finished sections.

For door or window openings, always work from the corner, moving toward the opening. Just before the wheels reach the opening, lock the handle and lift the wheels to keep them from dropping into the opening, then sweep away from the wall.

Before starting the finish coat, lightly sand the dried topping coat to remove any small crumbs. Fill the 10" or 12" (250-300 mm) box and set the dial to #3 for a medium crown. Apply a finish coat to all joints. For butt joints, apply a coat on either side of the center of the joint. After the two side by side coats have dried, finish them with a 10" or 12" (250-300mm) skim coat over the center of the joint.

Reset the crown dial to #5 for a tight crown then cover the joints on the ceilings and walls.

Maintenance

To open the boxes for cleaning, simply turn the two latches on the back and pull open. Clean thoroughly with a brush and water (or a water hose) to remove all joint compound from the tool. Then, after the tool is clean, lightly oil with Ames[®] Bazooka[®] Oil or any light machine oil.

Box Blade Replacement

1. To remove the used blade, place the tip of a screwdriver against one end of the blade and tap the screwdriver with the palm of your hand.
2. If the blade does not pop out, tighten the screw at one end of the brass blade holder, forcing the end of the blade out. Back the screw up and again tap the end of the blade.
3. Use one end of the used blade to clean any dried compound from the blade holder slot.
4. Remove both right and left skids, but leave the repair clips in place.
5. Slightly bend the new blade approximately 2 inches from both ends. This will help secure the blade while the tool is in use.
6. Start at one end, pressing the blade all the way into the blade holder, working to the other end. Install new skids. The "dog ear" on the skids should press against the back side of the new blade and be flush with the blade holder (about the thickness of a thumbnail lower than the blade edge).

Common Wear Parts

7" (175mm) Stainless Steel Blade: 200001
10" (250mm) Stainless Steel Blade: 250001
12" (300mm) Stainless Steel Blade: 300001

Skid Cover (Right): 209006
Skid Cover (Left): 209039